

# AN INVESTIGATIVE STUDY OF SUITABILITY OF SYNTHETIC COMPOSITE AS A LEAF SPRING MATERIAL FOR LCVs

Dr.G. Naga Malleswara Rao<sup>1</sup>, Mr.R.Somraj<sup>2</sup>, Dr.V.Nagaprasad Naidu<sup>3</sup> Mr.R.Mariannan<sup>4</sup>

*1-Professor Sri Venkateswara College Of Engineering & Technology, Chittoor*

*2-Associate Professor, Sri Venkateswara College of Engineering & Technology, Chittoor*

*3-Principal, Intell Engineering College Anathapuramu*

*4-Associate Professor, Sri Venkateswara College of Engineering & Technology, Chittoor*

\*\*\*

**Abstract** - Traditionally, the structural materials used in the manufacture of Leaf springs are steels. The trend is towards development of non-traditional leaf spring structural materials to cater the need for weighing wide range of loads to obtain finished products with high dimensional accuracy and surface finish. Synthetic composite is such a material formed by mixing and bonding together a carefully selected 'mix' of filler (glass fibre) and a resin, unsaturated polyester (binder) at room temperature. In this present work, a synthetic composite is manufactured, its properties are evaluated and leaf springs are designed for a Light Commercial Vehicle, Swaraz Mazda (8 Tons). In this study, it is found that, the leaf springs made up of these composites can replace the traditional leaf springs. The strength of the composite can be further enhanced by adding one more metal fibre. This trial is also under progress and fruitful results may be expected in near future.

**Key Words:** Structural material, Leaf springs, filler, Synthetic resin, metal fibre, cobalt naphthenate, methyl ethyl ketene peroxide.

## 1. INTRODUCTION\*

In order to conserve natural resources and economize energy, weight reduction has been the main focus of automobile manufacturer in the present scenario. Weight reduction can be achieved primarily by the introduction of better material, design optimization and better manufacturing processes. The suspension leaf spring is one of the potential items for weight reduction in automobile as it accounts for ten to twenty percent of the unsprung weight. This helps in achieving the vehicle with improved riding qualities. It is well known that springs, are designed to absorb and store energy and

then release it. Hence, the strain energy of the material becomes a major factor in designing the springs.

The relationship of the specific strain energy can be expressed as

$$U = \frac{\sigma^2}{\rho E}$$

Where  $\sigma$  is the strength,  $\rho$  the density and E the Young's modulus of the spring material. It can be easily observed that material having lower modulus and density will have a greater specific strain energy capacity. The introduction of composite materials was made it possible to reduce the weight of the leaf spring without any reduction on load carrying capacity and stiffness. Since; the composite materials have more elastic strain energy storage capacity and high strength-to-weight ratio as compared to those of steel. [1]

In every automobile, i.e. four wheelers and railways, the leaf spring is one of the main components and it provides a good suspension and it plays a vital role in automobile application. It carries lateral loads, brake torque, driving torque in addition to shock absorbing. The advantage of leaf spring over helical spring is that the ends of the spring may be guided along a definite path as it deflects to act as a structural member in addition to energy absorbing device. The geometry of the Steel leaf spring is shown in Fig. 1.

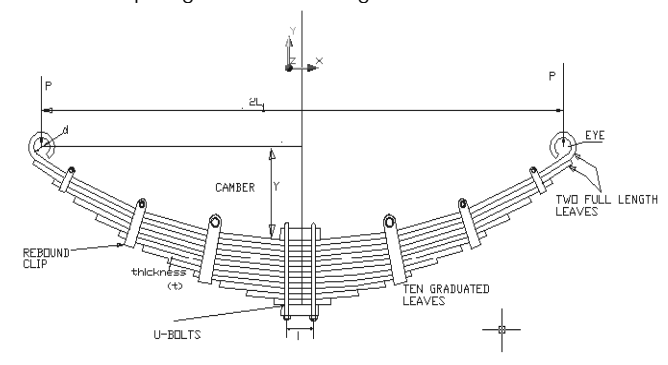

Fig. 1. Leaf spring

## 2. OBJECTIVE OF THE PROBLEM

The objective of the present work is to design, and to find the suitability of the composite leaf spring for a light commercial vehicle.

## 3. DESIGN PARAMETERS OF STEEL LEAF SPRING:

Parameters of the steel leaf spring used in this work are shown in Table 1. The leaf spring of the Light commercial vehicle, SwarajMazda (Super) are taken for this work. [2, 3]

Table 1. Parameters of steel leaf spring

S.NO	Parameter	Value
1	Material selected Hardened Steel	55Si2Mn90
2.	Tensile strength (N/mm <sup>2</sup> )	1962
3.	Yield strength (N/mm <sup>2</sup> )	1470
4.	Young's modulus E (N/mm <sup>2</sup> )	2.1·10 <sup>5</sup>
5.	Design stress ( $\sigma_b$ ) (N/mm <sup>2</sup> )	653
6.	Total length (mm)	1060
7.	The arc length between the axle seat and the front eye (mm)	530
8.	Spring rate (N/mm)	25
9.	Normal static loading (N)	10000
10.	Available space for spring width (mm)	70-90
11.	No of leaves per spring for front axle	12
12.	for rear axle	17
13.	Breadth of the leaf (mm)	70
14.	Thickness of the leaf (mm)	5

## 4. DESIGN AND FABRICATION OF COMPOSITE LEAF SPRING:

Considering several types of vehicles that have leaf springs and different loading on them, various kinds of composite leaf springs have been developed. In multi-leaf composite leaf spring, the interleaf spring friction plays a spoil spot in damage tolerance. It has to be studied carefully. In this paper, a multi leaf composite leaf spring with uniform width and thickness throughout its length is designed.

The parameters of composite leaf spring and material properties are shown in Table 2

Table 2 Parameters of composite leaf spring

S.NO	Properties	Value
1.	Tensile modulus	9300 MPa
2.	Tensile strength of the material,	29.1423. MPa
3.	Compressive strength of the material	201.5 MPa
4.	Flexural modulus of the material,	9450 MPa
5.	Flexural strength of the material,	156.918 MPa
6.	No of leaves per spring	15
7.	Breath of leaf (mm)	73
8.	Thickness of leaf (mm)	10

### 4.1. Lay up Selection

The amount of elastic energy that can be stored by a leaf spring varies directly with the square of maximum allowable stress and inversely with the modulus of elasticity both in the longitudinal direction. Composite materials like the Glass / unsaturated polyester in the direction of fibers have good characteristics for storing strain energy. So, the lay up is selected to be unidirectional along the longitudinal direction of the spring. The unidirectional layup may weaken the spring at the mechanical joint area and require strengthening the spring in this region. [4,5]

### 4.2. Preparation of composites:

In present work the composites are prepared by hand lay-up technique. The matrix of unsaturated polyester and monomer of styrene are mixed in the ratio of 100:25 parts by weight respectively. Later methyl ethyl ketene peroxide 1% by weight as accelerator and cobalt naphthenate of 1% by weight as catalyst are added to the mixture and mixed thoroughly. The releasing agent of silicon is sprayed to glass mould and the matrix mixture is poured in to the mould. The glass fibre is added to matrix the mould. The glass fibre is added to matrix mould. The excess resin is removed from the mould and glass plate is placed on the top of the casting and allowed to cure for 24hrs at room temperature and then casting is placed at a temperature of 80oC for 4 hrs. The composite are released from mould and are cut to prepare test specimens.

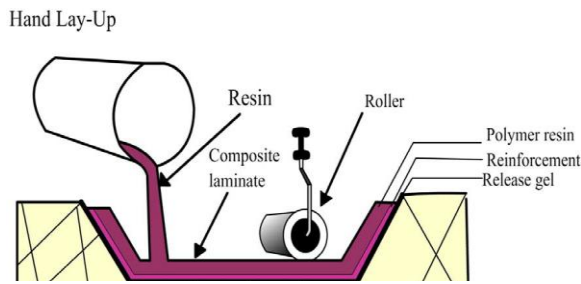

Fig:2 Hand lay -up process

#### 4.3. Specimen preparation and test machine:

The test specimens for both Compressive and Impact test were cut as per American Society for Testing and Materials (ASTM) D256 specifications. The Instron Universal Testing Machine (UTM) supplied by Instron Corporation, Series 9, automated testing machine) used for compressive test and Izod Impact testing machine used for Impact Testing.



Fig: 3 UTM series 9

Five samples are tested in each case and average value is tabulated.

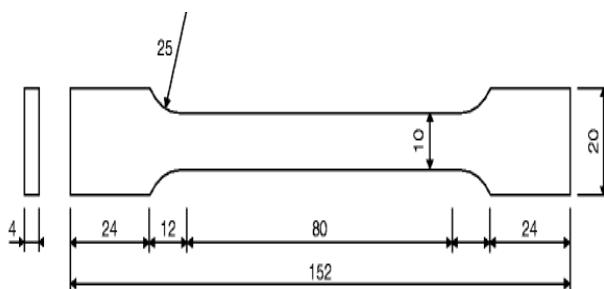

Fig: 4. Preparation of Specimen for Testing

#### 5. RESULTS AND DISCUSSION:

Since the composite leaf spring is able to withstand the static load, it may be concluded that there is no objection from strength point of view also, in the process of replacing the conventional leaf spring by composite leaf spring. Since, the composite spring is designed for same stiffness as that of steel leaf spring, both the springs are considered to be almost equal in vehicle stability. The major disadvantages of composite leaf spring are chipping resistance. The matrix material is likely to chip off when it is subjected to a poor road environments (that is, if some stone hit the composite leaf spring then it may produce chipping) which may break some fibres in the lower portion of the spring. This may result in a loss of capability to share flexural stiffness. But this depends on the condition of the road. In normal road condition, this type of problem will not be there. Composite leaf springs made of polymer matrix composites have high strength retention on ageing at severe environments. The steel leaf spring was replaced with a composite one. The objective was to obtain a spring with minimum weight which is capable of carrying given static external forces by constraints limiting stresses (Tsai-Wu criterion) and displacements. The weight of the leaf spring is reduced considerably about 75 % by replacing steel leaf spring with composite leaf spring. Thus, the objective of the unsprung mass is achieved to a larger extent. The stresses in the composite leaf spring are much lower than that of the steel spring

#### 6. CONCLUSIONS:

1. The development of a composite multi leaf spring having constant cross sectional area, where the stress level at any station in the leaf spring is considered constant due to the parabolic type of the thickness of the spring, has proved to be very effective;
2. The study demonstrated that composites can be used for leaf springs for light weight vehicles and meet the requirements, together with substantial weight savings;
3. A comparative study has been made between composite and steel leaf spring with respect to weight, cost and strength;
4. From the results, it is observed that the composite leaf spring is lighter and more economical than the conventional steel spring with similar design specifications;
5. Adhesively bonded end joints enhance the performance of composite leaf spring for delamination and stress concentration at the end in compare with bolted joints;
6. Composite leaf spring reduces the weight by 75 % for Glass fibre /unsaturated polyester over conventional leaf spring.

7. The strength of the composite leaf spring can be further enhanced by adding metal fibre instead of glass.

8. Alternate plates of composites and hardened steels can be banded to get very high strength in the spring and thus, cost can be reduced.

## 7. REFERENCES

1. Shiva Shankar, Vijayarangan.S. Mono Composite Leaf Spring for Light Weight Vehicle- Design, End Joint Analysis and Testing, ISSN 1392-1320, Material Science. Vol 12, 2006
2. Rajendran, I., Vijayarangan, S. Optimal Design of a Composite Leaf Spring using Genetic Algorithms Int. Jr. of Computer and Structures 79 2001: pp. 1121 – 1129.
3. Rajendran, I., Vijayarangan, S. Design and Analysis of a Composite Leaf Spring Journal of Institute of Engineers India 82 2002: pp. 180 – 187.
4. Daugherty, R. L. Composite Leaf Springs in Heavy Truck Applications. K. Kawata, T.Akasaka Eds). Composite Materials Proceedings of Japan-US Conference Tokyo, 1981: pp. 529 – 538.
5. Dharam, C. K. Composite Materials Design and Processes for Automotive Applications. The ASME Winter Annual Meeting, San Francisco, December 10-15,1978:pp.19-30

## BIOGRAPHIES



Prof. G.Naga Malleswara Rao, is having 17 Years of teaching experience and 7 years Of industrial experience his papers had been published national and international journals



Mr. R.Somraj , is having 11 years of teaching experience and one year in industrial experience, he has completed is B.E in Madras University and M.E in Anna University



Dr. V.Naga Prasad Naidu, is having 15 years of exexperience and completed his P.hd in developing new composite materials



Mr. R.Marianan , is having 13 years of teaching experience and 22years in industrial experience, he has completed B.E in Barathiar University and M.E in Sathyabama University