

A Review of Cascaded H-Bridge Multilevel Inverter: Control Techniques and its application

Sourabh Rathore¹, Mukesh Kumar Kirar², S.K.Bharadwaj³

¹ M.Tech Scholar, Electrical Engineering, MANIT Bhopal, Madhya Pradesh, India

² Assistant Professor, Electrical Engineering, MANIT Bhopal, Madhya Pradesh, India

³ Professor, Electrical Engineering, MANIT Bhopal, Madhya Pradesh, India

Abstract - Multilevel inverters (MLI) has largely attracted the attention of academic and industries. The demand of MLI has increased recently as it is capable of generating quality waveform by using low voltage devices, reduced switching frequencies and reduced harmonics content of the output power. There are several topologies discussed and analyzed in literature in past decades. In this paper, we have considered three topologies: Diode clamped inverter (DC-MLI), flying capacitor (FC-MLI), cascaded H-Bridge inverter (CHB-MLI). We have taken CHB-MLI as a reference for explaining three techniques: phase disposition (PD), phase opposition disposition (POD), alternate phase opposition disposition (APOD). After analyzing these three techniques, we observed that PD is best technique as it gives less total harmonic distortion (THD) content in voltage level.

Key Words: Cascade H-Bridge, Diode clamped inverter, flying capacitor, and phase disposition.

1. INVERTER

Power electronic inverter is a device which converts DC electrical power straight into HVAC electrical power. Throughout conversion, the actual result voltage as, well as usually is kept constant. This is termed series commutated inverters while that works inside inversion mode. Collection committed inverters involve HVAC offer in the course of conversion in the resulting terminal. [1], [2] This means that series committed inverters can't be the remote HVAC voltage places as well as being a variable regularity turbines along with DC electrical power in the suggestions. For that reason, voltage degree, regularity as well as waveform within the HVAC aspect in the series committed inverters can't always be changed.

The actual HVAC result voltage supply along with variable voltage worth as well as regularity worth so that you can have got a wide range of application. Inverters might be labeled straight into a couple kinds depending on their particular function [3]-[5]:

- Voltage Source Inverters (VSI)
- Current Source Inverters (CSI)

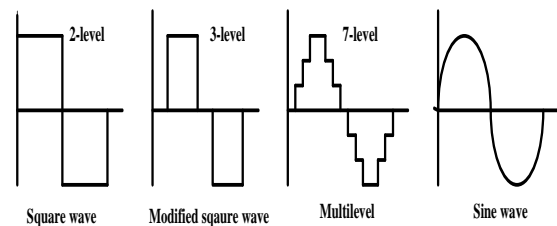

Fig- 1: Inverter output waveforms

Now we are going to classify multilevel converter into current source inverter, voltage source inverter.

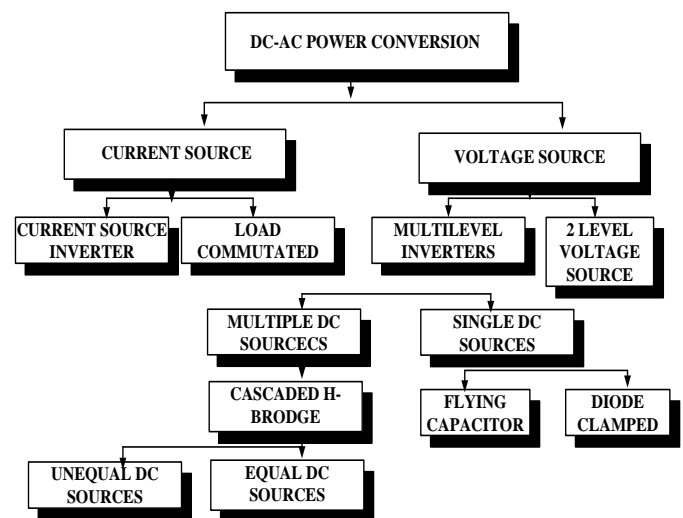

Fig-2: Classification of Multilevel converter

1.1 Multilevel Inverters

The multilevel inverter includes a variety of energy semiconductor gadgets and also capacitive voltage sources. The particular moved waveform connected with output voltage can be created [6], [7]. The particular commutation in the changes will allow the particular supplement in the capacitor voltages to obtain high-voltage at the output, as the energy semiconductors ought to withstand merely lessened voltages. The particular generalized moved waveform to get a single-phase N-level multilevel inverter can be revealed throughout Fig. 3 The particular waveform is composed of identical optimistic and also bad halves connected with $(N-1)/2$ voltage amounts where the sine wave may be approximated since revealed.

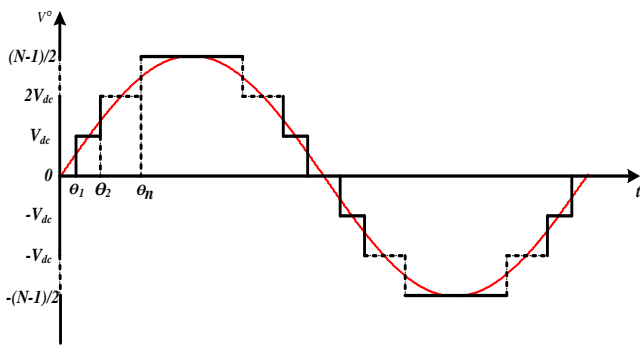

Fig-3.: Generalized stepped waveform of multilevel inverters

1) Diode-Clamped Multilevel Inverter (DC-MLI)

The diode-clamped multilevel inverter is the name given to neutral-point clamped PWM inverter extended to a higher number of levels [8]. The diode-clamped multilevel inverter has found wide acceptance for its capability of high voltage and high-efficiency operation. The power rating of the converter can be doubled. In addition to this the neutral point enables the generation of a zero voltage level, obtaining overall three different voltage levels [9]-[12].

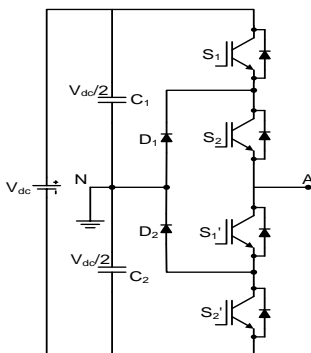

Fig-4 : A 3-level Diode-clamped inverter

Table-1: Switching Pattern of Diode-Clamped Multilevel Inverter

Output voltage $V_o = V_{an}$	Switch states			
	S_1	S_2	S_1'	S_2'
$V_{dc}/2$	1	1	0	0
0	0	1	1	0
$-V_{dc}/2$	0	0	1	1

Table-1 presents switching pattern of a 3-level diode-clamped inverter. State "1" indicates that the switch is ON and state "0" indicates that the switch is OFF. It is obvious from this table that in each cycle just four switches should be ON. It is evident from the table that a diode-clamped multilevel inverter does not possess phase redundancies.

2) Flying-Capacitor Multilevel Inverter (FC-MLI)

Figure 2.5 shows one phase leg of the power circuit for a flying-capacitor 3-level inverter. The FC-MLI topology is somewhat similar to DC-MLI while using the major difference becoming the clamping diodes are generally replaced through FC-MLI [62], since is so visible within Fig. 5 Any. Below the stress can't become directly linked to produce this absolutely nothing voltage stage. As an alternative, this absolutely nothing stage can be received through joining the stress on the beneficial or maybe adverse bar from the FC-MLI together with opposite polarity based on the dc-link. Like with this DC-MLI, a just pair of gating signs is essential for each period to prevent dc website link and also FC-MLI short-circuit. A different difference while using the NPC can be the several combining of Sw1; Sw2 are generally permitted. The middle circuit together with switch $(Sw1; Sw2) = (1, 0)$ which often yields this absolutely nothing stage. Identical stage can be received together with $(Sw1; Sw2) = (0, 1)$. That property or home is termed voltage stage redundancy and also can be used with regard to control or maybe optimization uses [12]-[15].

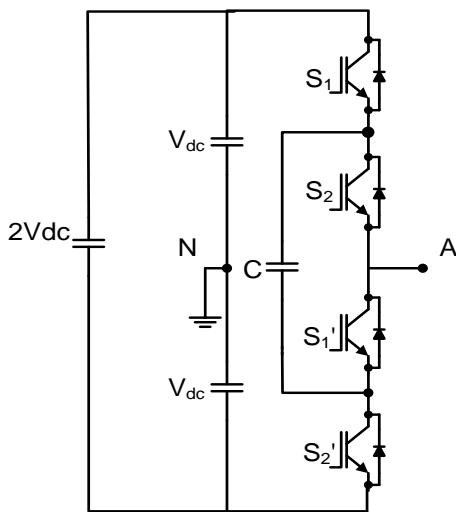

Fig-5: A 3-level flying capacitor inverter

Table-2: Switching Pattern of Flying-Capacitor Multilevel Inverter

Output voltage $V_o = V_{an}$	Switch states			
	S_1	S_2	S_1'	S_2'
V_{dc}	1	1	0	0
0	1	0	1	0
$-V_{dc}$	0	1	0	1
	0	0	1	1

As evident from table 2.4, FC-MLI multilevel inverter possesses phase redundancies. These redundancies can be incorporated in the control strategy which ultimately helps in regulating the voltage across the dc-link capacitors. The main advantages and disadvantages of FC-MLI multilevel inverter are listed below [16].

3) Cascaded H-Bridge Multilevel Inverter (CHB-MLI)

CHB-MLI is formed by the series connection of two or more single-phase H-bridge inverters; hence the name H-bridge is given [17]. Each H-bridge corresponds to two voltage source phase legs, where the line-line voltage is the inverter output voltage. Therefore, three different voltage levels are generated using a single H-bridge converter. And series connection of N such bridges can produce $2N+1$ levels in the output. This series connection is termed as cascaded H-bridge multilevel inverter [18]. Each leg has only two possible switching states, to neglect

dc-link capacitor short-circuit. Since there are two legs, four different switching states are possible, although two of them have redundant output voltage.

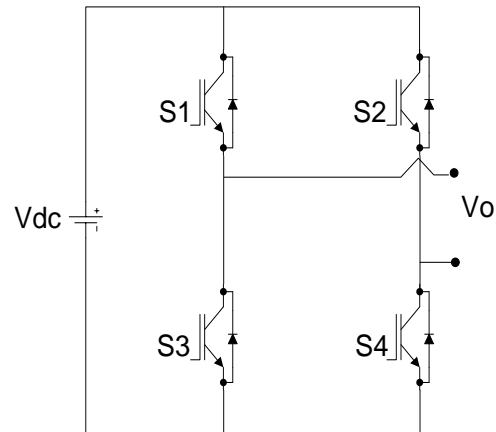

Fig-6: A 3-Level Cascaded H-Bridge Inverter

Table-3: Switching Pattern of Cascaded H-Capacitor Multilevel Inverter

Output voltage $V_o = V_{an}$	Switch states			
	S_1	S_2	S_1'	S_2'
V_{dc}	1	1	0	1
0	1	0	0	0
$-V_{dc}$	0	1	1	1
	0	0	1	0

The functioning of a single H-bridge is similar to that of conventional 2-level inverter. Each H-bridge requires an isolated dc source/capacitor to generate its corresponding output. The switches are activated in such a way that the output voltage across the load terminals is the aggregation of the voltage generated by all the H-bridges. The switching pattern for a 3-level inverter is shown in table 2.4.

2 MODULATION TECHNIQUES

Importantly the power electronic converters are operated in the "switched mode". The switches of the converter are always in either one of the two states - OFF (no current flows), or ON (saturated with only a small voltage drop across the switch). [19-21]. the switched component is

attenuated and the desired DC or low frequency AC component is achieved. That is called Pulse Width Modulation (PWM), since the desired average value is controlled by modulating the width of the pulses [22]-[26].

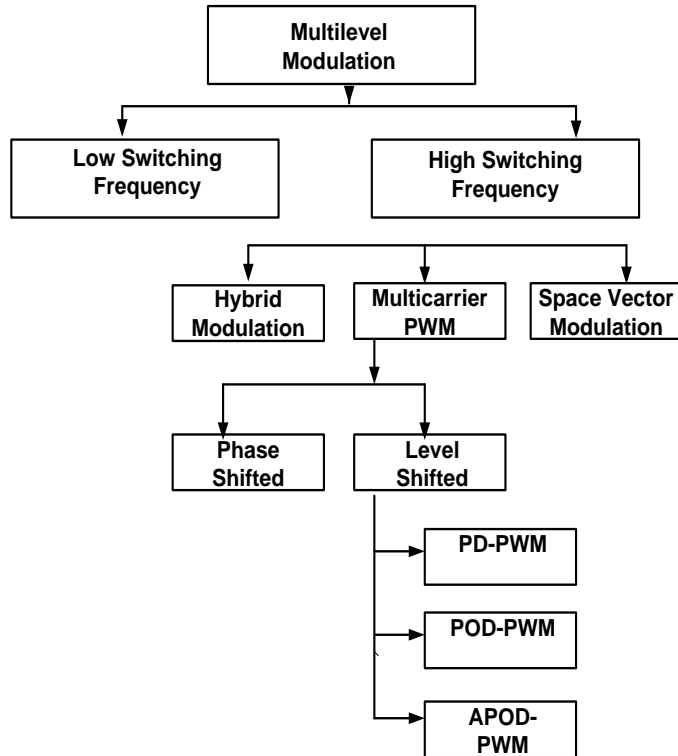

Fig-7: Classification of multilevel modulation methods

2.1 Multicarrier PWM

Multicarrier PWM is used when deals three level or higher levels in inverter output. Multilevel PWM is basically a generalization of the 2-level PWM wherein the sinusoidal reference signal is naturally sampled with the help of a number of carrier signals [27.]To be more specific, an *N*-level multilevel inverter requires *N-1* carrier signals to sample the reference signal and generate the switching signals for the power switches incorporated in the inverter topology [28].

2.1.1 Level Shifted PWM (LS-PWM)

It is the most important file format on the 2-level PWM with regard to N-level multilevel inverter when instead of just one provider signal, N-1 provider alerts are employed which are moved vertically with respect to the other [28]. Due to the fact just about every provider is usually related to two amounts PWM, the identical basic principle can be employed, using that this command signal needs to be aimed towards correct power turns so that you can make this related amounts within the end result [29]-[31].

- Phase Disposition (PD-PWM): wherein all the carrier signals are in same phase.

- Phase Opposition Disposition (POD-PWM): wherein the carrier signals above the zero are out of phase with those below the zero by 180°.
- Alternative Phase opposition Disposition (APOD-PWM): wherein the adjacent carrier signals are out of phase by 180°.

Table-4: Comparisons of Three Topologies

Topologies	Merits	Demerits
1.Diode Clamped	Control method is simple. Inverter efficiency is high.	More number of clamping diodes is required when the number of levels is high.
2.Flying Capacitor	Both real and reactive power flow can be controlled.	Inverter control can be very complicated when the no of levels is high.
3.Cascade H-Bridge	Compared with the NPC and FC inverters it requires the least number of components to achieve the same number of voltage levels.	It needs separate dc sources for real power conversions, thereby limiting its applications

3. CONCLUSIONS

In this paper there are three topologies: Diode clamped inverter, flying capacitor inverter, Cascade H-bridge inverter which have been discussed and analyzed considering all parameters and conditions. We have mentioned modulation techniques briefly. And the inverter topologies are then compared on the basis of

modulation techniques. The three technique of modulation Classified as: Phase disposition, Phase opposition disposition and Alternate Phase opposition are discussed considering all parameters. PD gives better result compared to POD, and APOD techniques.

REFERENCES

- [1]. H. Stemmler. "Power electronics in electric traction applications IEEE conference of Industrial Electronics, Control and Instrumentation," IECON'93, 1993
- [2]. H. Fujita, S. Tominaga, and H. Akagi. " Analysis and design of an advanced static VAR compensator using quad-series voltage-source inverters. " IEEE Industry Apps Meeting, 3:2565–2572, 1995
- [3]. Y. Yoshioka, S. Konishi, N. Eguchi, M. Yamamoto, K. Endo, K. Maruyama, and K. Hino. "Self-commutated static flicker compensator for arc furnaces. " In IEEE Applied Power Electronics Conference, volume 2, , 1996.
- [4]. L. L. Gyugyi, "Power electronics in electric utilities: static var compensators.," Proc. IEEE, vol.76,, 1987.
- [5]. Peter W. Hammond. " A new approach to enhance power quality for medium voltage AC drives. IEEE Trans. Industry Applications, 33(1):202–208, January 1997.
- [6]. L. M. Tolbert, F. Z. Peng, and T. G. Habetler, "Multilevel converters for large electric drives," IEEE Trans. Ind. Applicat., vol. 35, pp. 36-44, 1999.
- [7]. M. F. Escalante, J. C. Vannier, and A. Arzande "Flying Capacitor Multilevel Inverters and DTC Motor Drive Applications," IEEE Transactions on Industry Electronics, vol. 49, no. 4, Aug. 2002,.
- [8]. L. M. Tolbert, F. Z. Peng, "Multilevel Converters as a Utility Interface for Renewable Energy Systems," in Proceedings of 2000 IEEE Power Engineering Society Summer Meeting,
- [9]. L. M. Tolbert, F. Z. Peng, T. G. Habetler, "A Multilevel Converter -Based Universal Power Conditioner," IEEE Transactions on Industry Applications, vol. 36, no. 2, Mar./Apr. 2000
- [10]. A. Nabae, I. Takahashi, and H. Akagi, "A New Neutral-point Clamped PWM inverter," IEEE Trans. Ind. Applicat., vol. IA-17, pp. 518-523, Sept./Oct. 1981
- [11]. M. D. Manjrekar, P. K. Steimer, and T. A. Lipo, "Hybrid multilevel power conversion system: a competitive solution for high-power applications," IEEE Trans. Ind. Applicat., vol. 36,, 2000.
- [12]. Samir Kouro, Mariusz Malinowski et. al., "Recent Advances and Industrial Applications of Multilevel Converters", IEEE Transactions on industrial electronics, vol.57, no.8, pp. 2553- 2580, Aug 2010.
- [13.] Farhad Shahnian and B.B.Sharifian, "Harmonic analysis and modelling of transformerless electric railway traction drives," 13th International conference on Electrical Drives and Power Electronics (EDPE), Dubrovnik, Croatia, 26-28 Sep 2005.
- [14]. V.Kumar Chinnaiyan, Dr. Jovitha Jerome, J. Karpagam, and T. Suresh, "Control techniques for Multilevel Voltage Source Inverters," in Proceedings of The 8th International Power Engineering Conference (IPEC 2007), Singapore, pp. 1023-1028,3-6 Dec 2007.
- [15]. Muhammad H. Rashid, "Power Electronics Circuits, Devices and Applications," 3rd ed. , PEARSON publication, 2009.
- [16]. Jin Wang and Damoun Ahmadi, "A Precise and Practical Harmonic Elimination Method for Multilevel Inverters", IEEE Transactions on Industry Applications, vol. 46, no. 2, pp. 857-865, Mar-Apr 2010.
- [17]. Bin Wu, High Power Converters and AC Drives, IEEE Press, Wiley-Interscience, A John Wiley and Sons Inc., Publications, 2006.
- [18]. V. Naga Bhaskar Reddy, V. Narasimhulu, Dr. Ch. Sai Babu, "Control of Cascaded Multilevel Inverter by using carrier based PWM technique and implemented to Induction Motor drive," International Journeal on Automatic Control and System Engineering ICGST-ACSE Journal), vol. 10, Issue 1, Dec 2010.
- [19]. L. M. Tolbert, F. Z. Peng and T.G. Habetler, "Multilevel converters for large electric drives", IEEE Transactions on Industry Applications, vol. 35, no. 1, pp. 36-44, Jan/Feb 1999.
- [20] N. S. Choi, J. G. Cho, and G. H. Cho, "A general circuit topology of multilevel inverter," in Proc. IEEE PESC'91, 1991.
- [21] T. A. Meynard and H. Foch, "Multilevel conversion: High voltage choppers and voltage source inverters," in Proc. IEEE PESC'92, 1992.
- [22] M. F. Aiello, P. W. Hammond, and M. Rastogi, "Modular multi-level adjustable supply with series connected active inputs," U.S. Patent 6 236 580, May 2001.
- [23] P. D. Ziogas. The delta modulation technique in static PWM inverters. IEEE Trans 2004.
- [24] H. Ertl, J. W. Kolar, and F. C. Zach. " Basic considerations and topologies of switched-mode assisted

linear power amplifiers. IEEE Trans. Industrial Electronics, 44(1):116–23, February 1997

[25] Joachim Holtz and Bernd Beyer. "Optimal synchronous pulsewidth modulation with a trajectory tracking scheme for high dynamic performance. IEEE APEC'92, pages 147–154, 1992.

[26] N. V. Suryanarayan, "Utilisation of electric power including electric drives and traction", New Age International (P) Limited, 2005.

[27] Jagdish Kumar, Biswarup Das, and Pramod Agarwal, "Selective Harmonic Elimination technique for a Multilevel inverter," in Proc. of 15th National Power Systems Conference (NPSC), IIT Bombay,

[28] Burak Ozpineci, Leon M. Tolbert, John N. Chiasson, "Harmonic Optimisation of Multilevel Converters using Genetic Algorithms", IEEE Power Electronics Letters, vol. 3, no. 3.

[29] S. K. Pillai," A first course on electrical drives" , 2nd ed., New Age International Publishers, 2004.

[30] P. D. Ziogas." The delta modulation technique in static PWM inverters." IEEE Trans IndustrialApplications, IA-17(2):199–204, March 1981.

[31] Gupta, K.K.; Jain, S.; , "Topology for multilevel inverters to attain maximum number of levels from given DC sources," Power Electronics, IET , vol.5, no.4, pp.435-446, April 2012.

power system stability and control, transformer and machines.



S.K.Bharadwaj received the BE (Electrical) degree from I.T.B.H.U. Varanasi India In 1975 and M.Tech (Power System) in 1978 from REC Kurukshetra.and PhD (Application of self Tuning Strategies to electric Drive) in 2000 from Barkatullah University. He is currently working as a professor in the Department of Electrical Engineering, MANIT, and Bhopal, India. He has 9 research papers in National Conference and 7 research papers in International Conference His field of Interest are power system and energy conservation.

BIOGRAPHIES



Sourabh Rathore has received BE (Electrical) degree From Sagar Institute Research Technology and Science Bhopal in 2012 and pursuing his M.Tech degree in Power System from MANIT Bhopal.



Mukesh Kumar Kirar received the BE (Electrical) degree from Government Engg. College, Ujjain India in 2006 and M.Tech (Power System) in 2008 from MANIT Bhopal and PhD in 2014 from MANIT Bhopal. He is currently working as an assistant professor In the Department of Electrical Engineering, MANIT, Bhopal, India. His field of Interests is