

Loop Antenna and Rectifier Design for RF Energy Harvesting at 900MHz

Rahul Sharma¹, P.K. Singhal²

¹PG Student, Department of electronics, Madhav Institute of Technology and Sciency, Gwalior-474005, India
²Proffesor, Department of electronics, Madhav Institute of Technology and Sciency, Gwalior-474005, India

Abstract-Present era of wireless communication provides opportunity to harvesting energy from radiations. That can be used to excite low power devices. This paper reports a new microwave energy harvesting system to harvest energy from cellular network Frequency Band 900MHz.. A square loop antenna is designed and fabricated for deployment in proposed system. Proposed antenna is fabricated on FR4 (lossy) material. The characteristics of Proposed antenna are evolved and measured in term of return loss, VSWR, gain and radiation pattern. The gain of proposed antenna is 4db and efficiency 95%. A series Microwave rectifier configuration is used. Voltage measured at load is 400mv.

Key Words:Rectenna, Loop Antenna, Microwave Rectifier, Microwave Energy Harvesting wireless power transmission.

1. INTRODUCTION

A first preliminary study of wireless power transmission, by microwave beams, was accomplished in the early 1960 in United States [1]. In the background of microwave energy harvesting system [2-4] for low consumption wireless sensors, many microwave energy harvesting system have been accomplished in last few years. It can be forced that an rectenna, generating a workable amount of DC power to derive the Operation of a wireless devices, could be instrumental in the deployment of future wireless system with limited use of batteries. Hence, microwave energy harvesting has grown in to a new technology for wireless applications[5]. The rectenna is a fundamental instrument to collect electromagnetic power through free space and convert it in to DC power. Rectenna is a combination of receiving antenna and RF to DC rectifier. The rectifier is generally fabricated by combination of schottky diodes and output bypass capacitor. Impedance matching between receiving antenna and rectifier is essential to transfer maximum power [6, 7]. For a given RF power level, the conversion efficiency is mainly affected by diode losses and impedance mismatching.

The basic block diagram of microwave energy harvesting system is given in Fig. 1. There are three main elements in

the system to harvest energy, which are antenna, impedance matching circuit and rectifier.

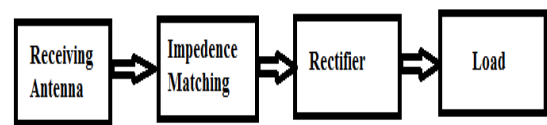

Fig-1: Block diagram of rectenna.

Different types of antenna already have been used in the design of rectennas, including dipole antennas [8], patch antennas [9], ring antenna [10]. For efficient microwave power harvesting, antenna is selected with more attention and accuracy for low return loss, high gain and high efficiency [11]. RF to DC conversion efficiency can be enhancing by rectifying circuit. Microwave rectifier designed with several topologies. The most used topologies are shunt and single series configurations.

The efficiency of the microwave rectifier is defined by

$$\eta = \frac{P_{DC}}{P_{Loss} + P_{DC}} \quad (1)$$

Where $P_{DC} = \frac{V_{out}^2}{R_L}$ and R_L is the load resistance, P_{DC} is the dc output power across R_L , V_{out} is the dc output voltage across R_L and P_{Loss} is the losses power.

A loop antenna is a radio antenna having a loop of wire, tubing, or other electrical conductor like copper with its ends connected to a balanced transmission line [12].

In This paper, the design and development of a loop antenna and single stage rectifier for microwave energy harvesting is presented. The proposed antenna resonates at 900MHz. This antenna is able to harvest energy from cellular Network signals. Cell tower can be used as a continuous source of sustainable energy because they transmit all the time. In india cell tower transmit 10 to 20W per carrier. The gain of antenna at resonant frequency is 4db. On other hand a high efficiency sensitive band rectifier is introduced. Impedance of rectifier is matched with impedance of loop antenna.

In first step, loop antenna and the rectifier are designed, fabricated then tested separately. Then the rectenna element is optimized by jointly simulating the antenna and tested over cellular network. To design the loop antenna CST Microwave studio software [13] is used. Computer Simulation Technology (CST) Microwave studio is a fully featured software package for electromagnetic analysis and design in the high frequency range.

2. LOOP ANTENNA DESIGN

In microwave energy harvesting, antenna is one of the most important component to harvest maximum power from ambiance. In this paper a loop antenna is designed and fabricated for rectenna. The main advantage of Loop antennas is to have one of the simplest designs for antennas known. The loop structure itself holds many advantages over standard dipole or patch type designs. The loop provides good matching for many types of inputs such as transmission lines and coaxial cables. It also has increased directivity not found in many simple designs. However, one of its main disadvantages over other simple antennas is the large surface area it requires. While a dipole design might only require space in one direction, the loop antenna requires a large planar surface area.

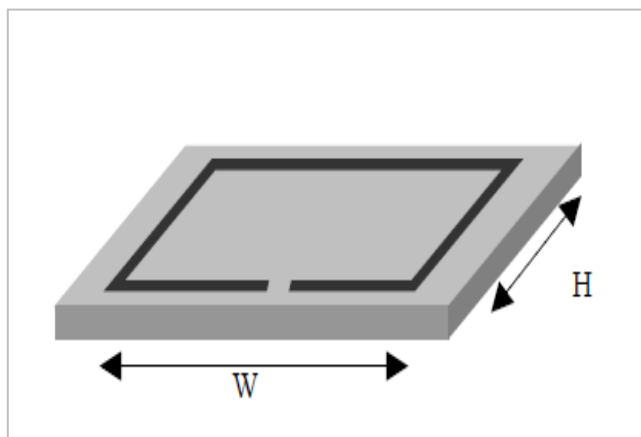

Fig- 2: Basic loop structure.

A thin copper Strip of Height 0.038mm loop antenna and sides $S = \frac{\lambda}{4}$ on an FR4 lossy substrate is simulated using CST software and fabricated. The loop antenna is centered in XY plain at $Z=0$. According to the requirement $\lambda = 333.3\text{mm}$. The total loop is divided in four arm. Hence length of each arm is 83.3mm. There is no ground plain in loop antenna.

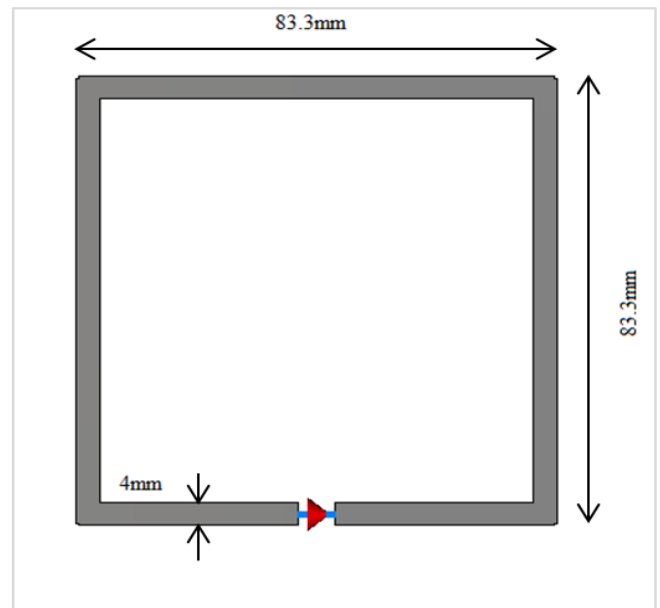

Fig- 3: Normal design loop antenna.

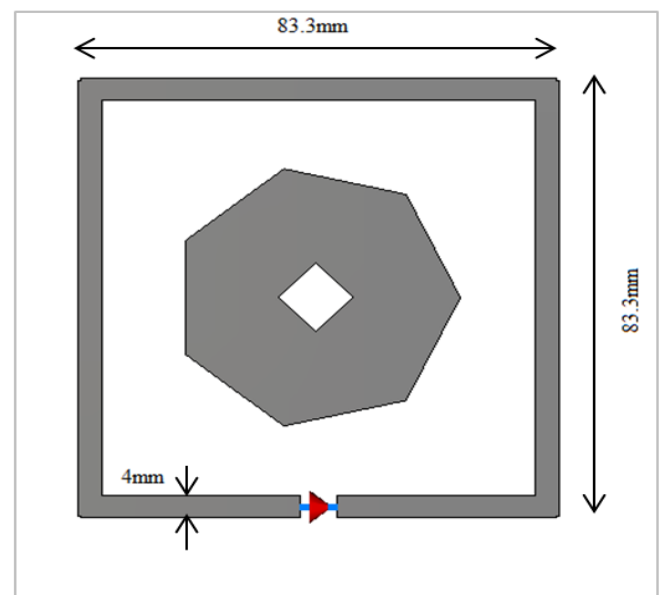

Fig- 4: Modified design of loop antenna.

The proposed antenna is a modified form of basic loop antenna. The modified loop antenna is shown in Fig. 4. The main intention to develop the modified loop antenna is to reduce reflection coefficient and to increases the performance of antenna. In modified loop antenna, a Heptagon patch of radius 29mm is embedded at center of normal loop antenna. A rectangular cut slot of radius 7.5mm is created at center.

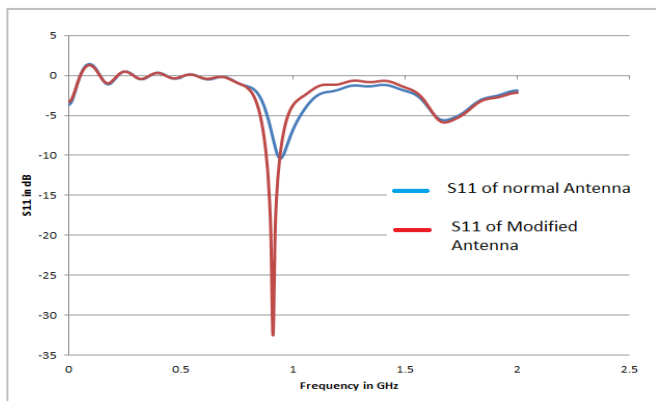

Fig- 5: Simulated Reflection coefficient of normal antenna and modified antenna.

Fig. 5 shows the comparison of simulated reflection coefficient between normal loop antenna and modified loop antenna. They both accurately predict the main resonance. But the reflection coefficients of modified loop antenna are better than the reflection coefficients of normal loop antenna. Hence modified loop antenna is preferable than the normal loop antenna. The optimum value of reflection coefficient is -32db at resonant frequency.

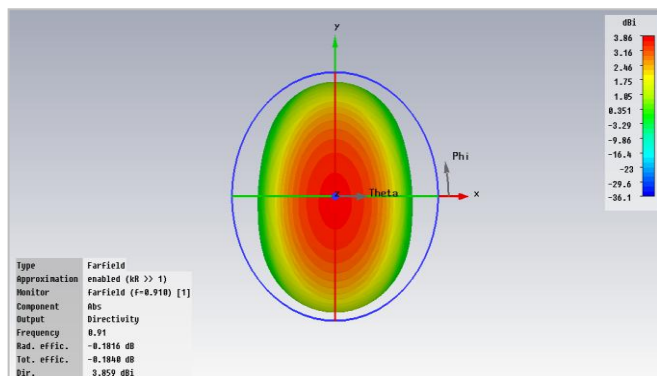

Fig- 6:3D radiation pattern of proposed antenna.

Fig.6 shows 3D radiation pattern together with azimuth and elevation plane definition. Azimuth angle is denoted by "theta" and angle of elevation is denoted by "phi". Azimuth angle is the angle between reference direction (north direction) and a point, at which our antenna will be placed in the ground plane and elevation angle is the angle between ground plane axis and tilted axis of the antenna. The total efficiency of proposed antenna is 95.85%.

Simulated VSWR and Gain plots of proposed antenna are shown in Fig. 7 and Fig. 8 respectively. VSWR of proposed antenna is less than 2 from 880MHz to 940MHz. This is under the tolerable VSWR. At resonant frequency 910MHz, VSWR is 1.05. Hence antenna is perfectly matched. Fig. 6 shows the gain plot of proposed antenna. At center frequency, gain of proposed antenna is 4db.

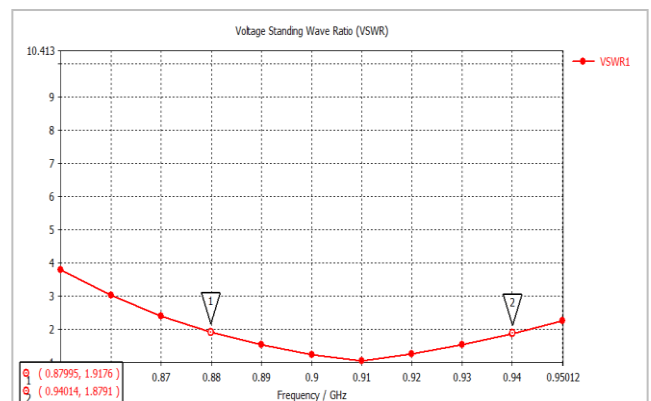

Fig- 7: VSWR of proposed antenna.

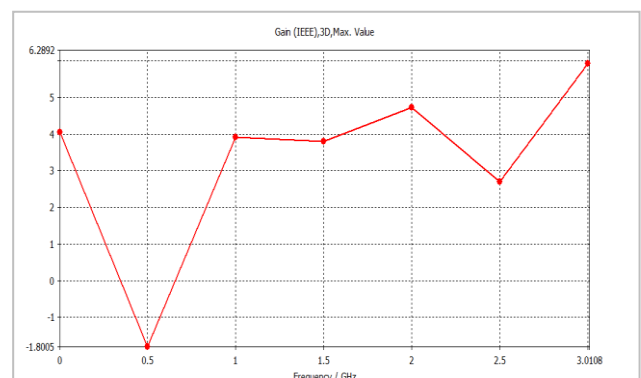

Fig- 8: Simulated Gain plot of proposed antenna.

Simulated VSWR and Gain plots of proposed antenna are shown in Fig. 7 and Fig. 8 respectively. VSWR of proposed antenna is less than 2 from 880MHz to 940MHz. This is under the tolerable VSWR. At resonant frequency 910MHz, VSWR is 1.05. Hence antenna is perfectly matched. Fig. 6 shows the gain plot of proposed antenna. At center frequency, gain of proposed antenna is 4db.

3. RECTIFIER CIRCUIT DESIGN

Fig. 1 shows the block diagram of energy harvesting system. The antenna, the impedance matching circuit and rectifier circuit are connected back to back. Impedance matching circuit is used to match the impedance of antenna to the impedance of rectifying circuit Rectifier circuit is used to convert Microwave power in to DC electric power. Fig.9 Shows the circuit model of proposed Rectifier Circuit.

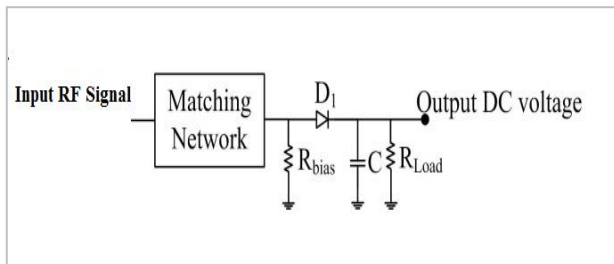

Fig- 9: RF to DC rectifier.

A silicon based schottky diode having threshold voltage of 230mV and diode capacitance of 0.26pF is chosen for rectifier. Here C is a charging Capacitor . At microwave Frequency, non linear capacitance of the diode governs the maximum power transfer to the load and amplitude of the rectifier output as input impedance of the rectifier changes with frequency.

4. RESULTS

The voltage levels are measured at actual site consisting a cell phone radiating electromagnetic waves at 900MHz. The voltage measured at load is 400mV using a voltmeter when proposed system is near to cell phone.



Fig- 10: Experimental demonstration of proposed system by LED glowing.

Here, a light emitting Diode is glowing without connecting it to any power source by wire. Fig. 11 demonstrates a photograph of LED Glowing with microwave energy harvesting system.

5. CONCLUSION

Present Paper describes simulation, fabrication, testing of highly efficient microwave energy harvesting system. A modified loop antenna is presented for microwave energy harvesting system to harvest energy at 900MHz electromagnetic wave source. This system consist rectifying circuit for converting power from RF to dc voltage and amplify same.

REFERENCES

- [1] W.C. Brown, "The history of power transmission by radio waves," *IEEE Trans. Microw. Theory Tech.*, vol. MIT-32, no.9, pp.1230-1242, sep.1984.
- [2] Piang, T., J. Morroni, A. Dolgov, J. Shin, "Wirelessly powered wireless sensor platform," *proc. of the 37th European Microw. Conference, Minich*, 999-1002, oct.2007.
- [3] Olgun, U., C.-C. Chen, " Design of an Efficient ambient WiFi energy harvesting system," *IET Microw. Antennas Propag.*, Vol. 5, No. 11, 1200-1206, 2012.
- [4] Hong, S. S. B. , R. Ibrahim, M. H. M. Khir, "Rectenna architecture based energy harvester for low power RFID application," *4th international conference on intelligent and advanced system* ,382-387, Petronas , Malaysia jun. 12-14, 2012.
- [5] J. O. Mcspadden , L. Fan, and K. Chang, "Design and experiment s of a high conversion efficiency 5.5GHz rectenna," *IEEE Tranc.Microwave Theory Tech.*, Vol. 46, no. 12, pp. 2053-2060, dec. 1998.
- [6] Ren, Y.J. and K. Chang, " 5.8GHz circularly polarized dual diode rectenna and rectenna array for microwave power transmission," *IEEE Trams. Microw. Theory.*, Vol. 54, No.1, 1495-1503, Apr. 2006.
- [7] Douyere, A., J.D. Lan Sun Luk, and F. Alicalapa, " High efficiency microwave rectenna circuit Modeling and Design," *Electronic Letters*, Vol. 44, No. 24, 1409-1410, Nov. 2008.
- [8] Shailendra Singh Ojha, P.K. Singhal, AnshulAgrawal. "2-GHz Dual Diode Dipole Rectenna For Wireless Power Transmission," *International Journal of Microwave and Optical Technology*, vol.8, No.2, March 2013.
- [9] WalidHaboubi, Hakim Takhedmit, Jean - Danial L.S. Luk, "An efficient dual - circularly polarized rectenna for RF Energy harvesting in the 2.45GHz ism band," *Progress in Electromagnetic Research*, Vol. 148, 31-39, 2014.
- [10] Y. J. Ren, M.-Y. Li, and K. Chang, " 35 GHz rectifying antenna for wireless power transmission," *Electron. Lett.*, Vol. 43, no. 11, pp. 602-603, May 2007.
- [11] HanaeElftough, Naina A. Touhami, "Miniaturized Microstrip patch antenna with Defected ground structure," *Progress in Electromagnetic Research c*, Vol. 55, 25-33, 2014.
- [12] R. Hasse, V. Demir, W. Hunsicker, "Design and analysis of portioned square loop antennas," *ACES Journal*, Vol. 23, No. 1, March 2008.
- [13] CST microwave studio software 2010.

BIOGRAPHIES



Rahul Sharma is currently pursuing masters degree program in Electronics and communication (Microwave Engineering) in Madhav Institute of Technology and Science Gwalior, India. His research interest includes Antenna and Microwave communication and their applications.



Dr. P.K. Singhal presently working as a professor & Head in Department of Electronics in Madhav Institute of Technology Science, Gwalior, India. He has published more than hundred research paper, which include paper in IEEE transaction, international & national journals and conferences. His research interest includes electromagnetic, antennas, microwave circuits & communication systems.