

Angular Variation Methodology For Landslide Measurement Using Programmable System on Chip

Mr. Chetan C. Dakave¹, Dr. M. S. Gaikwad².

¹ Asst. Prof., Department of Electronics & Telecommunication Engg., P.V.P.I.T. Sangli, Maharashtra, India

² Professor, Department of Electronics & Telecommunication Engg., S.I.T. Lonavala, Maharashtra, India

Abstract - In this project we are implementing with PSoc 4 Pioneer development hardware which contains an accelerometer sensor which means MEMs sensor and other environment monitoring sensors like Ultrasonic sensors. The details are monitored and send through wireless communication module Zigbee to Another node called as access point which receives the alert message from land slide detector and enables a voice for alarming civilians as well as this system send alert message civilians. This project continuous monitoring enables pre detection of landslide.

Key Words: PSoc 4, GSM, ZigBee, Sensors.

1. INTRODUCTION

In India mass of failure slide mainly happens especially due to heavy rainfall which leads to considerable loss of life, communication damage, damage to agricultural and forestlands. The annual loss sometimes even crossed around \$600 million. Landslide repeatedly at Western Ghats including Vindhya mountain range and north-eastern region including Himalayan region and a section of has a significant problem of land-slide[2].

Hilly are mass failures, which includes movement in soil, rock, ice which cause a considerable damage to the natural habitat, reliability, environment and other resources. Measurement, monitoring and control are the three major issues regarding RTA (Real Time Application). For a large scale of fault and monitoring the faults is one of the important applications that lead to advancement of many kind of technologies. In this project a Landslide detection system is being developed at Bidholi(village), Dehradun, India, a region with high rainfall and versatile climatic behavior most of the year.[2] Integrating Geophysical sensors forming a heterogeneous wireless network helps in identifying the fault and this paper also includes development, deployment (analysis) and data retrieval of the sensors information using WSN.

The landslide measurement, detection and monitoring system presented in this project is remotely accessible via internet and provides real-time information about the current state of the monitored slope.

This PSoc 4 Pioneer Kit is based on the PSoc 4200 device family and IC CY8C4245-AXI, deliver a programmable platform for a wide range of VLSI and embedded applications. The PSoc 4 is a reconfigurable and scalable platform architecture for a family of mixed-signal programmable embedded system controllers with an ARM® Cortex™-M0 CPU.

2. PROPOSED SYSTEM

A wireless sensor networks used to alarm the effects of landslides well in advance before land sliding occurs. The proposed work considers ZigBee sensors node for the application with the access point. The data received from the sensors through wireless transceiver receives and transmitted to the access point or the base station. Continuous monitoring can also be done. When the MEMs sensor gets tilted some voltage gets produced when this voltage reaches or increases the threshold value it will produce an alert. It can be detected and monitored from the base station[1].

This project presents the design and implementation of ZigBee transceiver for IEEE 802.15.4. It has been aimed to achieve a complete ZigBee transceiver for short range wireless communication keeping in mind for military application. Each standard supporting short range wireless communication has different specifications and different applications. Though the mobile communication has achieved wide applicability, but for application of short range communication in isolated area mobile communication is very difficult to implement. ZigBee transceiver provides a resilient technology to communicate in shorter range.

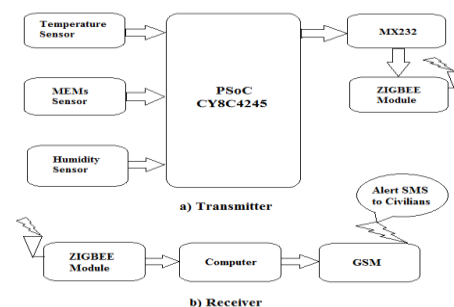

Fig -1: Block Diagram of Landslide Control System

3. HARDWARE DESIGN

3.1 PSoC 4 Pioneer Kit 4200:

The kit is designed as an easy-to-use and inexpensive development kit, showcasing the unique flexibility of the PSoC 4 architecture. This kit offers footprint-compatibility with several third-party Arduino™ shields. This kit has a provision to populate an extra header to support Digilent Pmod™ peripheral modules. In addition, the board features a CapSense, an RGB LED, a push button switch, an integrated USB programmer, a program and debug header, and USB/UART/I2C bridges. This PSoC4 Pioneer kit supports either 3.3 V or 5V as power supply voltages.

This PSoC 4 Pioneer Kit is based on the PSoC 4200 device family and IC CY8C4245-AXI, deliver a programmable platform for a wide range of VLSI and embedded applications. The PSoC 4 is a reconfigurable and scalable platform architecture for a family of mixed-signal programmable embedded system controllers with an ARM® Cortex™-M0 CPU. PSoC4 combines programmable and reconfigurable analog and digital blocks with flexible automatic routing.

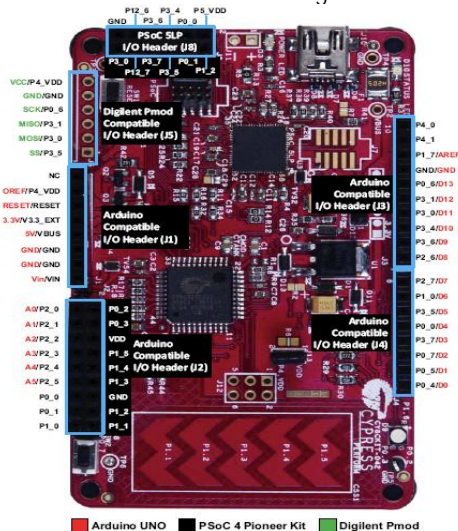

Fig -2: PSoC 4 Pioneer Kit 4200

3.2 ZIGBEE

Wireless transmission can be achieved by a device which facilitate the signal trans-receiving. This 2.4 GHz frequency for general purpose as well as educational purpose. This is developed by integrating ETHERNET service along with ZigBee for smooth and optimum data comparison, conversion and transmission. The size of the module is so small which can be easily portable for this application.

There were many wireless modules available in the market, but the reliability, high transmission range,

low cost, capability, ease of interfacing and low power consumption with regarding to NODE turns the views of the project to use the ZIGBEE module as a medium of communication.

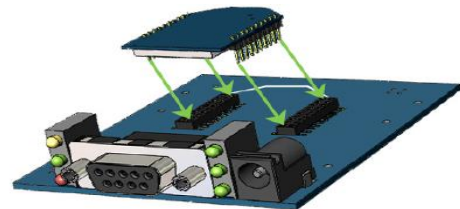

Fig -3: Zigbee Module

3.3 Sensors:

A) LM 35:



Fig -4: LM 35 Temperature Sensor

The LM35 series are precision integrated-circuit temperature sensors, whose output voltage is linearly proportional to the Celsius (Centigrade) temperature. The temperature sensor LM35 thus has an advantage over linear temperature sensors calibrated in °Kelvin, as the user is not required to subtract a large constant voltage from its output to obtain convenient Centigrade scaling. The LM35 does not require any external trimming or calibration to provide typical accuracies of $\pm 1/4^\circ\text{C}$ at room temperature and $\pm 3/4^\circ\text{C}$ over a full -55 to $+150^\circ\text{C}$ temperature range.

B) Humidity Sensor:

The operating principle of these capacitive relative humidity sensors is based on the hygroscopic properties of a polymer coating, which changes capacitance in response to local RH. The polymer reaches equilibrium with the ambient RH quickly and changes its capacitance value and reversibly.

- FF: Probe/Sensor,
- Variables Measured: Temperature, Relative Humidity,
- Relative Humidity Range: 0.0 to 100 %,
- Relative Humidity Accuracy: 1.5 %.



Fig -5: Humidity Sensor

C) MEMS Sensor:

The MMA7260QT low cost capacitive micromachined accelerometer features signal conditioning, a 1-pole low pass filter, temperature compensation and g-Select which allows for the selection among 4 sensitivities. MEMs sensor zero-g offset full scale span and filter cut-off are factory set and require doesn't external devices. MEMs sensor includes a Sleep Mode that makes it ideal for handheld battery powered electronics.



Fig -6: MEMs Sensor MMA7260QT

4. SOFTWARE DESIGN

4.1. PSoC Creator:

PSoC Creator 3.0 is a free Windows-based Integrated Design Environment (IDE). PSoC Creator enables concurrent hardware and firmware design of PSoC 4, PSoC 5LP and PSoC 3 based systems. Create designs using classic, familiar schematic capture supported by over 100 pre-verified, production ready PSoC Components.

With PSoC Creator, you can:

- Drag and drop component icons to build your hardware system design in the main design workspace.
- Co-design your application firmware with the PSoC hardware, using the PSoC Creator IDE C compiler.
- Components configure using the configuration tools.
- Explore the library of 100+ components.
- Component review datasheets[1].

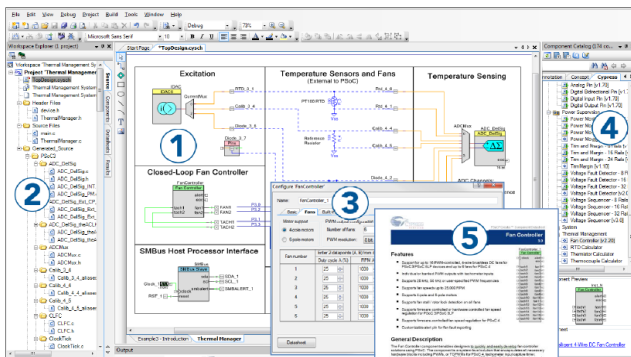

Fig -7: PSoC Creator Tool

5. NODE FABRICATION

Transmitter Node is the master node that will control all the sensor information that is being gathered through various sensors and transmits to the data to the Receiver Node across two intermediate nodes that helps in efficient transmitting of the gathered data without any missing information.

5.1 Transmitter Node:

Transmitter node consists of The CY8C38 devices a true programmable embedded system-on-chip, integrating configurable analog and digital peripherals, memory, and a microcontroller on a single chip and transmit the information using ZIGBEE and as well compare the obtained values with stored values, that helps in stability and time with respect to rate of change[2].

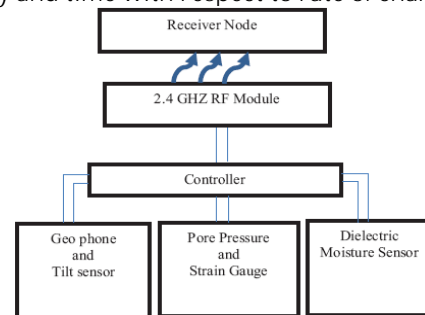

Fig. -8: Transmitter node

5.2 Receiver Node:

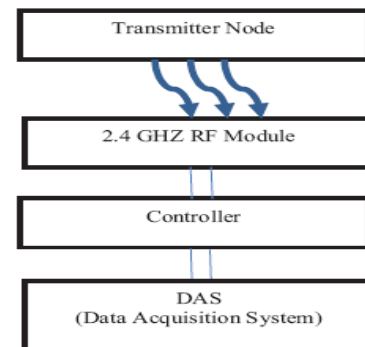

Fig. -9: Receiver node

The flow chart developed above only explains how the information is transmitted by the Transmitter Node to the Receiver Node and receiving end analysis. Intermediate nodes Node1 and Node2 comprises by ZigBee module and acts as Trans/Receiver Nodes[2].

6. RESULTS

In results when our system monitor faulty observations then system alert first to base station civilians and throw base station we inform to civilians.

Table -1: Results

Parameters	Normal Observations	Faulty Observations
Temperature	29	35<
Humidity	45	60<
Tilt Angle	49	45<

7. CONCLUSIONS

This proposed work is for detect disaster like landslide, measuring different parameters using physical sensors and PSoC. If defect is present then alert through wireless sensor network. DAS (Data Acquisition System) at the control station or base station is equipped with all the necessary protection equipment for all necessary measures which can be easy for the officials to take necessary steps for disaster protection like landslide. By using of WSN any physical, mechanical or geo-physical sensors can be easily interfaced to protect of our livelihood as well as **nation's wealth**.

REFERENCES

- [1] Landslide Detection and Alert System Using PSoC, International Journal of Innovative Research in Computer Science & Technology (IJIRCST) ISSN: 2347-5552, Volume-3 Issue-3, May-2015.
- [2] Land Slide Detection and Monitoring System using Wireless Sensor Networks (WSN). N. L. Ravi Teja¹, V. K. R. Harish², Nayeem Muddin Khan D³, R. Bhargava Krishna⁴, Rajesh Singh⁵, S Chaudhary⁶ 1,2,3,4 Robotics Engineering, University of Petroleum and Energy Studies, Dehradun, India 5, 6 Electronics, Instrumentation and Control Engineering, University of Petroleum and Energy Studies, Dehradun, India.
- [3] Real-time Wireless Sensor Network for Landslide Detection Maneesha V. Ramesh Department of Computer Science, Amrita School of Engineering Amrita Vishwa Vidyapeetham (AMRITA University) Clappana. P.O, Vallikkavu, Kollam, Kerala, India-690525 maneasha@amritapuri.amrita.edu.

- [4] Landslide Monitoring with Sensor Networks: Experiences and Lessons Learnt from aReal-World Deployment Alberto Rosi*, Nicola Bicocchi, Gabriella Castelli, Marco Mamei, Franco Zambonelli.
- [5] Ramesh, M. V., Real-time Wireless Sensor Network for Landslide Detection, Proceedings of the Third International Conference on Sensor Technologies and Applications, SENSORCOMM 2009, IEEE, Greece, June 18-23, 2009.
- [6] Tien-wen seng, Ting-Ting wu, et.al., Reliable Data Broadcast for ZigBee Wireless Sensor Networks, Intelligent journal on smart sensing and intelligent systems, Vol 3, No. 3, September 2010.
- [7] Y.P. Sharda, Landslide Studies in India, Glimpse of Geo science Research in India, The Indian report to IUGS, 2004-2008, Indian National Science Academy, Silver Jubilee Volume, 2009, pp 98-101.
- [8] An Autonomous Landslide Monitoring System based on Wireless Sensor Networks K. Georgieva¹, K. Smarsly², M. König¹ and K. H. Law².
- [9] www.cypresssemiconductor.com.

BIOGRAPHIES

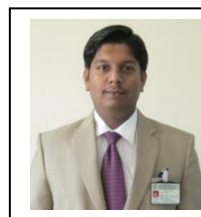

Mr. C. C. Dakave, Asst. Prof, Department of Electronics and Telecom., P.V.P.I.T. Budhgaon, Sangli. Doing M.E. VLSI & Embedded Systems in Sinhgad Institute of Technology, Lonavala. Published 4 International Journal Papers and 4 National Journal/Conference Papers.



Dr. M. S. Gaikwad, Professor, Department of Electronics and Telecommunication, Sinhgad Institute of Technology, Lonavala. The Principal of Sinhgad Institute of Technology, Lonavala. Guided PhD as well as M.E. students in Savitribai Phule Pune University.