

DESIGN FOR MONITORING AND OPTIMIZATION OF POWER DEMAND FOR WIRELESSLY COMMUNICATING ELECTRIC LOADS

Patil Snehal S.S.¹, Mr. Shivdas S.S.²

¹M. E. Electronics (II), Department of Electronics Engineering; K.B.P. college of Engineering, Satara, Dist-SATARA; Maharashtra, India

²Associate Professor, Department of Electronics Engineering; K.B.P. college of Engineering, Satara, Dist-SATARA; Maharashtra, India

Abstract: India's century-old electrical grids brought the nation inexpensive, abundant power and changed the way the country worked filling homes, streets, businesses, towns and cities with energy. What they also did was pay little regard to the environment. Unidirectional by nature, the grids were designed to distribute power, not to manage a dynamic global network of energy supply and demand. The result is, today India's grids account for some of the highest transmission and distribution losses in the world, at around 27%. This inadequacy could possibly become an obstacle to the country's progress in the years to come. It enables monitoring, analysis, control and two-way communication between the electrical delivery system and the consumer end. Smart grids use sensors, digital meters and controls and analytical tools to automate, monitor and control flow of energy and hence provide detailed and timely information on energy consumption. In this proposed system with effective solutions for multiple problems faced by India's electricity distribution system such as varying voltage levels experienced due to the varying electrical consumption, power theft and transmission line fault for single phase electricity distribution system.

Keywords: Load scheduling, power optimization, WSN wireless sensor network

1 .INTRODUCTION

A smart grid is a digitally enabled electrical grid that gathers, distributes, and acts on information about the behavior of all participants (suppliers and consumers) in order to improve the efficiency of electricity services or it is a technique used to increase the connectivity, automation and coordination between the suppliers, consumers and networks that perform either long distance transmission or distribution. The objectives of smart grid are fully satisfy customer requirements for electrical power, optimize resources allocation, ensure the security, reliability and economic of power supply, satisfy environment protection constraints, guarantee power quality and adapt to power market development.

Smart grid can provide customer with reliable, economical, clean and interactive power supply and value added services. Electricity losses in India during transmission and distribution are extremely high vary between 30 to 45%. For residential consumers' class, the representative daily curves by utility and by consume range were defined. For each utility, the singular ranges

were grouped and were finally: 0-50; 51-200; 201-300; 301-400 kWh/month [1].

New technologies include cutting-edge advancements in information technology, sensors, metering, transmission, distribution, and electricity storage technology. It will be able to providing new information and flexibility to both consumers and providers of electricity [2]. The ZigBee Alliance, wireless communication platform is presenting new smart home wireless system implication by having a new initiative to create smart homes that improve energy management and efficiency. Wireless sensor networks (WSNs) will play a key role in the extension of the smart grid towards residential premises, and enable various demand and energy management applications.

2 .PRESENT THEORY AND PRACTICES

After enactment of Electricity Act '2003 in India, a comprehensive change is happening in Indian power sector, and power distribution utilities are going through a reformation process to cope up with the regulatory change

for reduction in Aggregated Technical and Commercial Loss, improvement in Power Quality, Reliability of Power Supply, Improvement in Customer Satisfaction and rationalization of electricity tariff [2].

A Dynamically Reconfigurable Architecture for Smart Grids [3] introduces a proposal for a smart grid management platform built on the distributed programming paradigm. Besides it is based on information model and event architecture. The information model **defines a set of clear interfaces to manage every "grid node"**. It presents embeddable control/meter device that may even be attached to individual appliances. These devices behave as conventional autonomous remote distributed objects and provide full support for the information model.

A consumption scheduling mechanism for home area load management in smart grid using integer linear programming (ILP) technique [4] provides scheduling to minimize the peak hourly load in order to achieve an optimal (balanced) daily load schedule. The proposed mechanism is able to schedule both the optimal power and the optimal operation time for power-shiftable appliances and time-shiftable appliances respectively according to the power consumption patterns of all the individual appliances.

Smart Meters for Power Grid [5] presents the Smart meter is an advanced energy meter that measures consumption of electrical energy providing additional information compared to a conventional energy meter. Integration of smart meters into electricity grid involves implementation of a variety of techniques and software, depending on the features that the situation demands.

Wireless Smart Grid Design for Monitoring and Optimizing Electric Transmission in India presented by Aryadevi Devidas. Wireless network based architecture is proposed for monitoring and optimizing the electric transmission and distribution system in India. The system consists of multiple smart wireless transformer sensor node, smart controlling station, smart transmission line sensor node, and smart wireless consumer sensor node [6]. This design incorporates effective solutions for **multiple problems faced by India's electricity distribution system** such as varying voltage levels experienced due to the varying electrical consumption, power theft, manual billing system, and transmission line fault.

Development and assessment of Wireless Sensor and Actuator Network (WSAN) for load management can be implemented for university environment [7]. It mainly focused on monitoring and controlling oh heating and cooling loads. The control of the system can be forced for the specific period of time based on the collected data. This system provides the solution to manage the energy

which results the approximately 15% reduction of the peak power demand.

Smart home energy management system using IEEE 802.15.4 and ZIGBEE [8], this innovative system presents various home appliances, smart sensors and energy technologies. It presents the view towards smart energy market, which requires two types of ZigBee networks for device controlling and management of energy. It consists of a multi-sensing, heating and airconditioning system and actuation application for home users. This system introduces smart home interfaces and device definitions to allow interoperability among ZigBee devices.

3. THE DEVELOPED SYSTEM ARCHITECTURE

The proposed system with effective solutions for **multiple problems faced by India's electricity distribution system** such as varying voltage levels experienced due to the varying electrical consumption, power theft and transmission line fault for single phase electricity distribution system.

3.1. System Design:

Figure 1 shows the functional description of the system to monitor electrical parameters and control appliances based on the consumer requirements. The measurement of electrical parameters of home appliances is done by interfacing with fabricated sensing modules. Current Transformer sensor is step down transformer and Potential Transformer sensor is also a step down transformer The output signals from the sensors are integrated and connected to ZigBee module for transmitting electrical parameters data wirelessly.

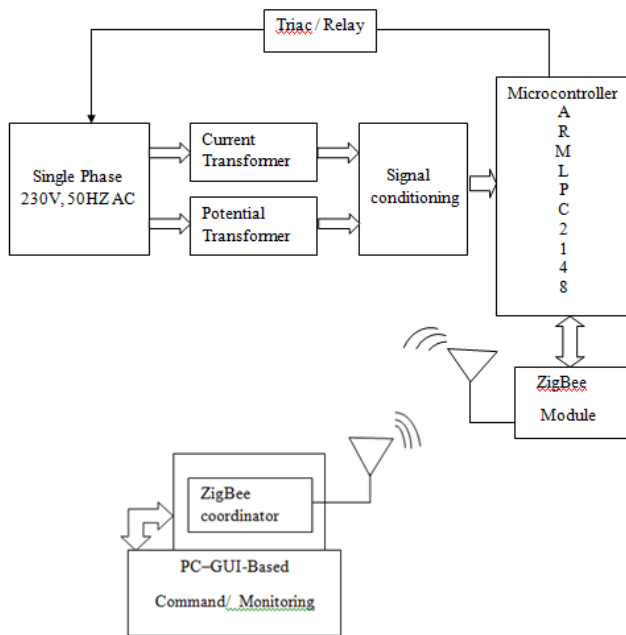

Figure1. Block Diagram for monitoring of Energy Utilization

The ZigBee modules are interfaced with various sensing devices and interconnected to have reliable data reception at a centralized ZigBee coordinator. The maximum distance between the adjacent ZigBee nodes is less than 10 m, and reliable sensor fusion data has been performed. The ZigBee coordinator has been connected through the USB cable of the host computer, which stores the data into a database of computer system. The appliances are controlled either automatically or manually. The smart power metering circuit is connected to mains 230 V/50 Hz supply.

By monitoring consumption of power of the appliances, data are collected by a smart coordinator, which saves all data in the system for processing as well as for future use. The parameters will be entered in the data coordinator in software from appliances include voltage, current, and power. These parameters will be stored in a database and analyzed. Collected data will be displayed on the computer through graphic user interface (GUI) window so that appropriate action can be taken from the GUI.

3.2. Signal conditioning:

In order to measure the phase voltage, frequency and phase, signal conditioning circuit should be interfaced with microcontroller system. Here step down transformer is used to convert the input phase voltage into small range of voltage. Rectifier circuit follows the down converted voltage and given the ADC channel in suitable range.

3.3.ZIGBEE interfacing :

In the proposed system, two ZIBBEE modules are used. Transmitter ZIGBEE module is used for collecting electrical parameter such as power. Collected data is passed wirelessly which is received at ZIBBEE coordinator. This module is connected to PC. Received data is processed in GUI. GUI stores the data which is useful for future work.

4. PRINCIPLE OF OPERATION

The system will have many constrains in it. Complete system can be divided into two units. First unit consists of a PC along with MATLAB and Zigbee module. This unit is required to get the data from microcontroller and display it on screen.

In this system, we mainly focus on two loads having different power ratings. System focuses on power scheduling. for power scheduling PWM pulse width modulation technique is used. by varying pulse width of required load, it is possible to vary the power of that load. For energy optimization, various loads can be categorized in power shiftable and time shiftable loads.

5. HARDWARE AND SOFTWARE REQUIREMENT

1. ARMLPC2148.
2. PC.

3. ZIGBEE Module.
4. Current Transformer.
5. KEIL and other relevant software tools.
6. MATLAB

6. SOFTWARE FLOWCHART

Figure.2 shows the software flowchart of proposed system. In flowchart, power scheduling is achieved by varying pulse width from 100% to 1%. This is useful to achieve optimization of time shiftable and power shiftable appliances.

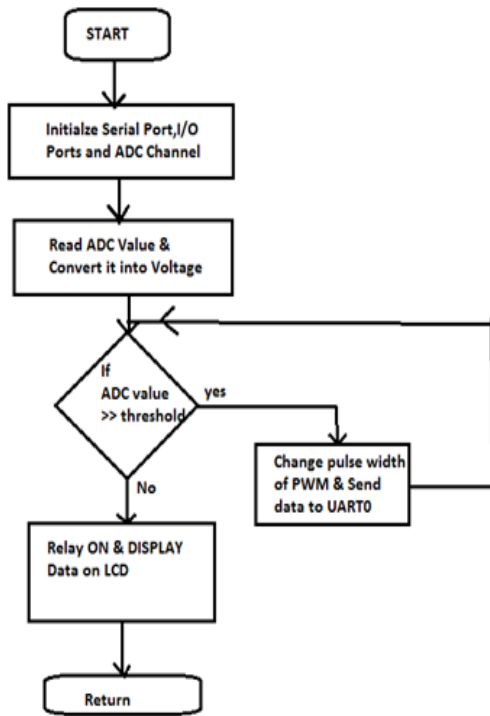

Figure 2 :Software flowchart of the system

7. SIMULATION RESULT AND SYSTEM MODEL

In this system MATLAB tool is used to show graphical representation of power consumption of two

loads. Figure 3 shows the initial total power consumption of two loads.

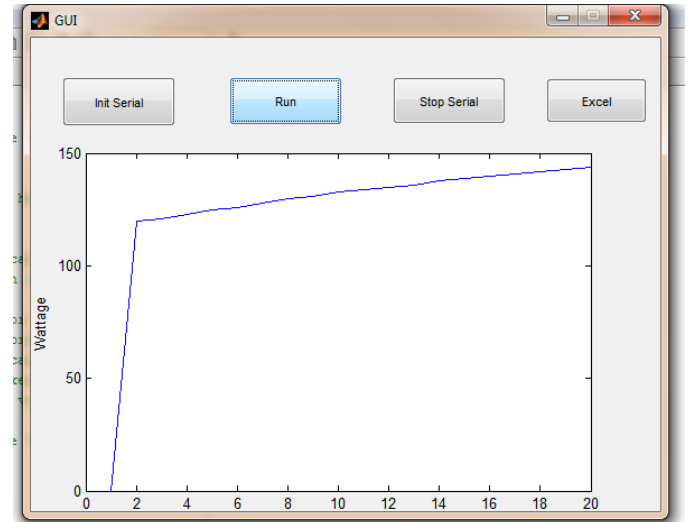

Figure.3: Simulation result

In figure 4, it shows, power scheduling of two loads started. Total power is reduced from peak value to its threshold value. Again the same scheduling is applied.

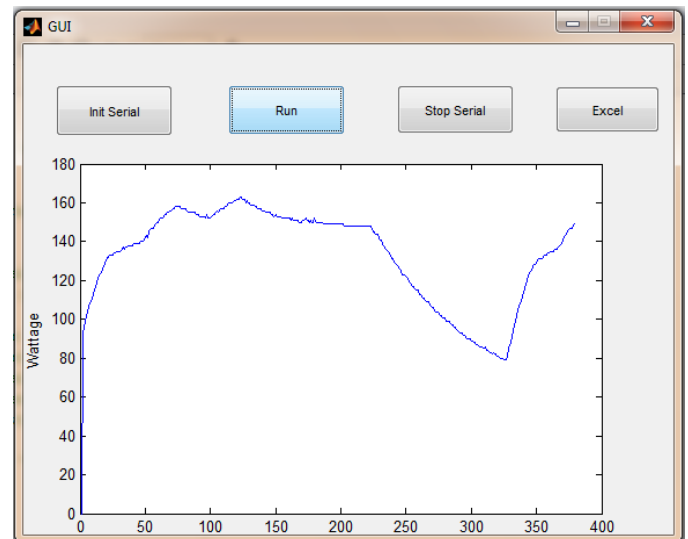

Figure.4: Simulation result

Figure 5 shows same optimization algorithm is repeated and same output power curve is repeated. Power scheduling is achieved by using PWM technique.

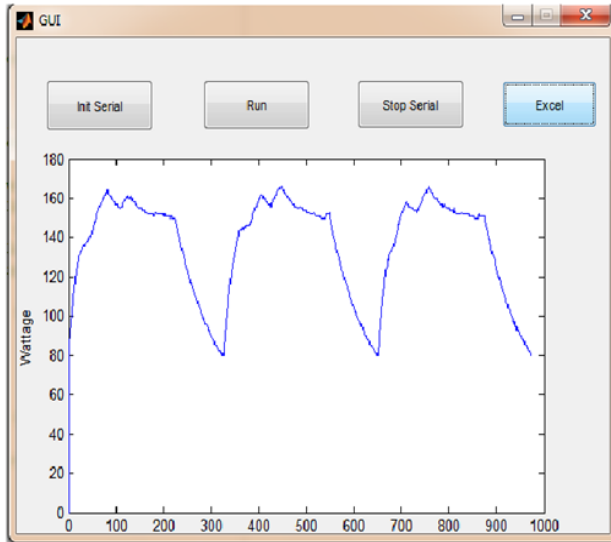

Figure.5: Simulation result

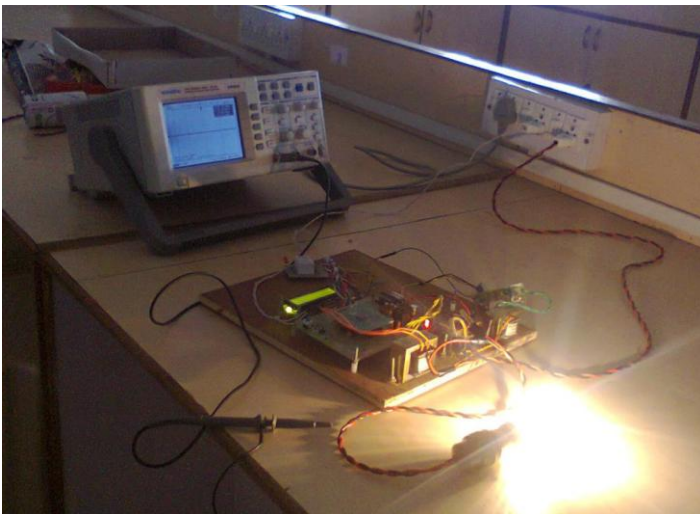

Figure.6: Developed system model

8. CONCLUSION

Current situations show that electricity control is mainly done manually, from switching lights and appliances to control heating systems. However, user activities and behaviors have large impact on energy consumed in all sectors of buildings such as residential, offices and retail sectors. Significant amount of energy spent for these buildings can be saved by using wireless sensor and actuator network. In order to realize this approach, user activities and behaviors are required as the most important input for energy efficient management. This proposed architecture is an effective solution for monitoring and optimizing energy utilization. The system design mainly concentrates on single phase electric distribution system, especially suited for Indian scenario. The system provides the solution for some of the main problems faced by the existing Indian grid system, such as wastage of energy. The proposed system based optimization mechanism for the home demand-side management in smart grid is able to schedule the optimal power for power-shiftable appliances and time-shiftable appliances respectively. Simulation results shows that in order to minimize peak hourly load L and to get more optimized power consumption the hourly power consumption of Power shiftable appliances and Time shiftable appliances should be minimum.

REFERENCES

- [1] José Antonio Jardini, Fellow, IEEE, Carlos M. V. Tahan, M. R. Gouvea, Se Un Ahn, Member, IEEE, and F. M. Figueiredo, Student Member, IEEE "Daily Load Profiles for Residential, Commercial and Industrial Low Voltage Consumers", IEEE Transactions On Power Delivery, vol. 15, no. 1, pp. 1710–1721, January 2000
- [2] A. Sinha, S. Neogi, R.N. Lahiri, S. Chowdhury, S.P. Chowdhury and Chakraborty, "Smart Grid Initiative For Power Distribution Utility In India", IEEE, vol.5, no.3, pp. 422–430, 2011.
- [3] D. Villa, C. Martin, F.J. Villanueva, F. Moya and J.C. Lopez, "A Dynamically Reconfigurable Architecture For Smart Grid", IEEE Transactions on Consumer Electronics, vol.57, no.2, pp 1392-1398, May 2011.
- [4] Ziming Zhu Senior Member IEEE, "An Integer Linear Programming Base Optimization For Home Demand-Side Management In Smart Grid", vol.3, no. 2, pp. 134–139, 2011.
- [5] S.S. Reddy Depuru, L. Wang, V. Devabhaktuni and N. Gudi, "Smart Meters For Power Grid-Challenges, Issues, Advantages And Status", IEEE, vol.7, no.4, pp. 1434–1439, 2011.

[6] Aryadevi Devidas "Wireless Smart Grid Design For Monitoring And Optimizing Electric Transmission in India", Fourth international conference on Sensor Technology and Applications, pp 342, Aug 2010 .

[7] Angel Molina-Garcia, Juan Alvaro Fuentes, Emilio Gómez-Lázaro ,Alberto Bonastre, José Carlos Campelo, and Juan José Serrano," Development and Assessment of a Wireless Sensor and Actuator Network for Heating and Cooling Loads" IEEE Trans. Smart Grid, vol. 3, no. 3, pp 1122-1229, Sept. 2012.

[8] D.-M. Han and J.-H. Lim:"Smart Home Energy Management System using IEEE 802.15.4 and ZigBee" IEEE Transactions on Consumer Electronics, Vol.56, no.3, pp 1192-1202, Aug. 2010.

BIOGRAPHIES

	Miss. Patil Snehal S. M. E. Electronics (II), Department of Electronics Engineering; K.B.P. college of Engineering, Satara, Dist-SATARA; Maharashtra, India
	Mr. Shivdas S.S. Associate Professor , Department of Electronics Engineering; K.B.P. college of Engineering , Satara, Dist-SATARA; Maharashtra, India