

Modeling and Emulation of Control Panel Instruments for PFBR Operator Training Simulator

H.Seetha¹, N.Jasmine², T.Jayanthi³, S.A.V.SatyaMurthy⁴

¹ Scientific Officer-E, Computer Division, Indira Gandhi Centre for Atomic Research, Tamilnadu, India

² Scientific Officer-D, Computer Division, Indira Gandhi Centre for Atomic Research, Tamilnadu, India

³ Scientific Officer-H, Computer Division, Indira Gandhi Centre for Atomic Research, Tamilnadu, India

⁴ Outstanding Scientist, Computer Division, Indira Gandhi Centre for Atomic Research, Tamilnadu, India

Abstract - Modeling and emulation of control panel instrument by soft virtual panel for Prototype Fast Breeder Reactor (PFBR) operator training simulator have need of better understanding of process instrumentation and its control methodologies, software ability to implement and integration of the same in simulator environment. Process Instrumentation & control is a vast area where 100% emulation of a component and its control in real time simulation environment is not achievable. Hence some of the instruments are conceptually emulated to represent the functionality of the PFBR main control room for simulator development phase. Models simulated in the development phase have been verified and validated by the emulated instruments in soft panels and tuned to meet the simulator requirement specification as per the Nuclear power plant operator training simulator standard i.e. ANSI 3.5/1998. PFBR virtual panel emulation includes object development, invoking with proper format in its corresponding panel position to handle more than 10000 process parameters without any clashing and integration with the other models like process and controls. This paper details about the modeling and emulation of instrument object with some example, scope of the instruments, merits & demerits of the same and integration with the panel screens using virtual panel modeling tool for PFBR full scope replica type operator training simulator i.e. KALBR-SIM (KALpakkam BReeder SIMulator) development purpose. It also describes about the steps followed for component emulation, challenges in implementation of instrument dynamics, state change incorporation, results of integrated soft panels, merits of instrument emulation in development stage and conclusion.

Key Words: PFBR, Operator training simulator, emulation of process instrument, Virtual panel, instrument modeling, simulation

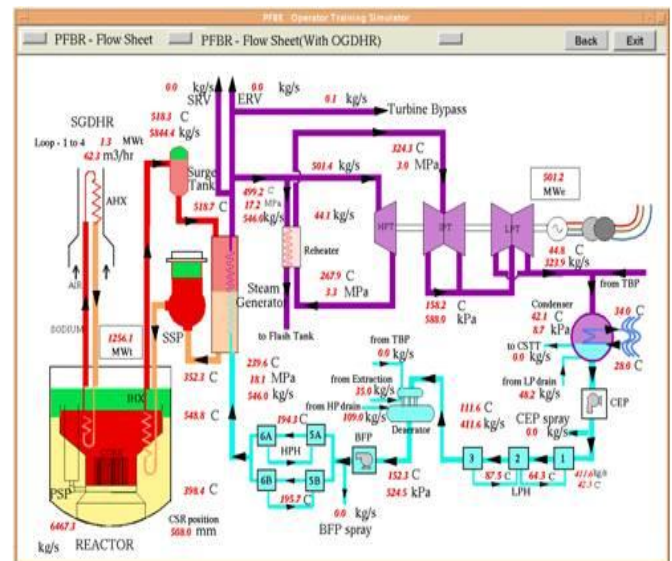

Fig-1: PFBR Simulator flow sheet

1. PFBR OPERATOR TRAINING SIMULATOR

PFBR is India's first fast breeder reactor with 500 MWe capacity, pool type reactor utilizing sodium as main heat transport medium and uses mixed Uranium, Plutonium oxide as fuel. Heat Transport system consist of Primary Sodium System, Secondary Sodium system and Steam Water System. Steam Water System adopts a reheat and regenerative cycle using live steam for reheating. Energy transfer is done through Electrical System using turbo alternator set of capacity 500 MWe. (Refer fig-1)

Successful operation of any nuclear power plant requires a carefully planned training program for the engineers, supervisors and operators. The operators are expected to have acquired the necessary theoretical knowledge as well as practical knowledge in operating the controls in the control room, before they can be authorized to operate the plant. PFBR full scope replica type operator training simulator is developed as per Atomic Energy Regulatory Board guidelines at Computer Division in collaboration with Reactor Design Group and Nuclear Safety & Engineering group of IGCAR [1]. Full scope simulator simulates various reactor states and systems starting from

nuclear core to turbo generator and replica feature are brought into the simulator control room by providing 1:1 correspondence with main control room with respect to its panels, desks, chairs and lighting arrangement etc [2] and [3].



Fig-2: PFBR control panels

2. PFBR CONTROL PANELS

Control panels in any process control plants are flat, often vertical and area where high quality analog / digital instruments are placed for extensive range of process, electrical and electronic parameters for control or monitoring instruments are displayed. Control panels are most often equipped with push buttons, selector switches, digital indicators, pen recorders and analog instruments. PFBR has three main control centres for different purposes and geographically distributed also.

Main control Room (MCR) panels for plant control at normal scenario, Backup Control Room (BCR) panels for emergency control & monitoring of plant SCRAM state where MCR is inaccessible due flood / fire and Handling Control Room (HCR) for offline fuel handling [4] and [5]. Hence it is mandatory to emulate and integration with the respective process/ control logic for all the components for 20 control panels / 7 operator consoles of MCR, 2 control panels of BCR and 4 control panel / 4 operator consoles of HCR. (Refer fig-2).

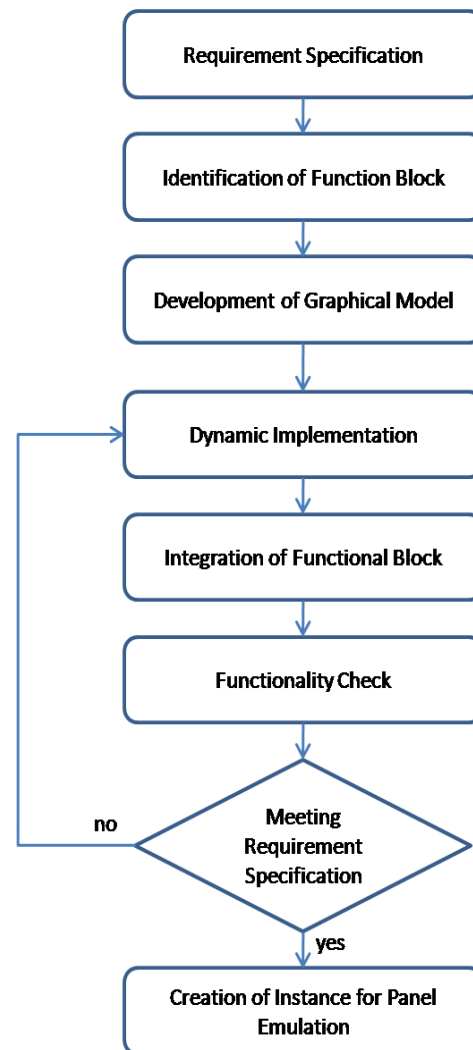

Fig-3: Steps followed for instrument emulation

3. INSTRUMENT EMULATION

Emulating process / control instruments like multiple state selector switch, gang switch with illuminated lamp, momentary push button, single scaled dial, dual scaled dial and multiple channel pen recorder etc, developers has to acquire the knowledge of the instrument like how well the device would function if actually build. Getting information in the early stage will resulting in reduction in the development time and men hours involved. The emulation includes understanding the specification of the instrument as per the designer requirement, identifying functional block to emulate the function in real time, development of graphical model to represent the instrument, implementing dynamic, test the emulated function by configuring the data as per the requirement and finally create instance wherever required in the panel Emulation (Refer fig-3).

4. PUSH BUTTONS

Push button is the instrument used as remote control for the power plant component. Two variety push buttons like on/off and momentary type are used in PFBR control room. Momentary push button is a simple electric switch for occasions where the operator wants to change the state momentarily. For more permanent long-term changes, a momentary switch would be inappropriate, there on/off state push buttons are used. This on/off push button switch is a small, sealed mechanism that completes an electric circuit when it selected by the operator. When it's selected once it will go to an on state, a small metal spring inside makes contact with two wires, allowing electricity to flow and it will in the on state up to the next selection. Next selection it will go to an off state, the spring retracts, contact is interrupted, and current won't flow. The body of the switch is made of non-conducting plastic. State selection is confirmed by the illuminated lamp in build with the buttons.

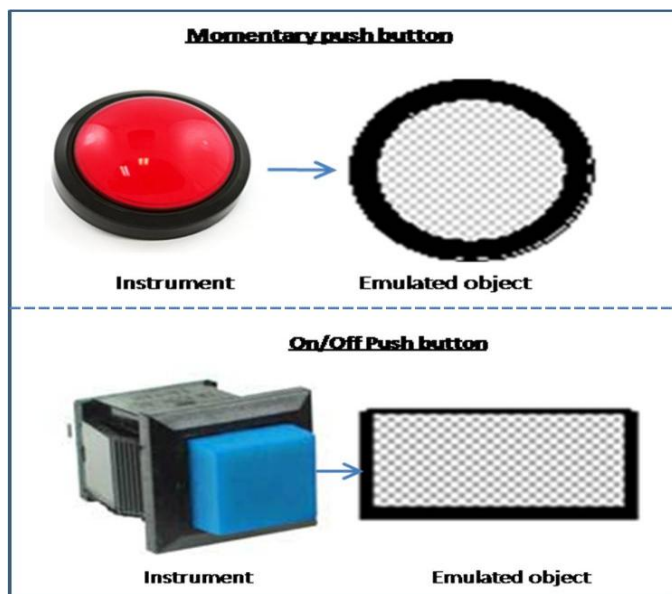

Fig-4: Push button and its graphical representation

Emulation of momentary and on/off type push button is completed by two layer of representation for on and off state (Refer fig-4). In that dynamics are superimposed for changing the fill color or redraw the same state after receiving the mouse click action. Momentary push button objects are emulated to create instances in PFBR control panels like speeding up/ slowing down of primary & secondary sodium pump (one push per rpm), raising /lowering the Control & Safety Rod, inhibiting negative reactivity in manual power setback state to avoid SCRAM, decay heat removal system air damper open/close (one push/degree).

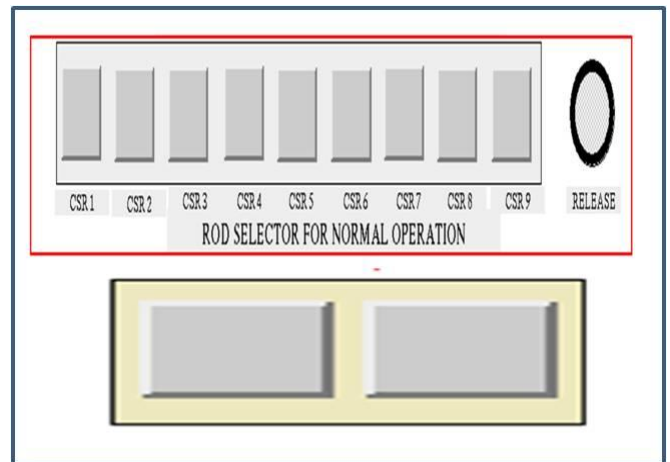

Fig-5: Graphical representation of objects for with / without release logic

5. GANGED SWITCHES WITH/WITHOUT RELEASE BUTTON

Ganged switch is a group of push buttons with toggling dynamic where one push button is selected previously selected button has come to the off state automatically. Two types of ganged switches are used in PFBR; with release button and without release (Refer Fig-5). Instance like CSR selection for rod exercises facility / normal operation, pump selection to raise / lower the speed, thermal power range selection and instrumented central subassembly power range selection enabled by this ganged switches in PFBR control panel. Refer table-1 for the logical difference between these two types of ganged switches.

Table:-1 Difference between with/without ganged switch

With Release	Without release
Button off state is automatic by selecting the other button	Button off state is by selecting release button in the end of the gang.
There is no state called "none of the state is selected".	This ganged switch is designed purposely to make the state "none of the state is selected". Represented by means of release button selection

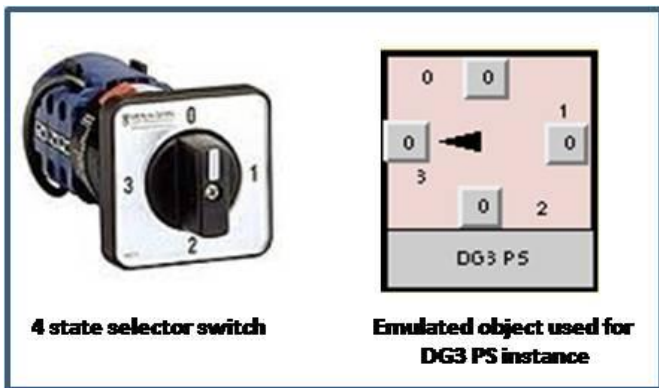

Fig-6 Instance for 4 state selector switch

6. SELECTOR SWITCH

Selector switch is a simple control panel instrument where the operation of state change of component / system / plant in a sequential order is carried out. A rotary selector's switch consists of a spindle/rotor that has a contact arm which projects from its surface like a cam. It has an array of terminals, arranged in a circle around the rotor, each of which serves as a contact for the arm through which any one of a number of different electrical circuits can be connected to the rotor. The switch is layered to allow the use of multiple poles; each layer is equivalent to one pole. Usually such a switch has a detent mechanism so it "clicks" from one active position to another rather than stalls in an intermediate position. (Refer fig-6)

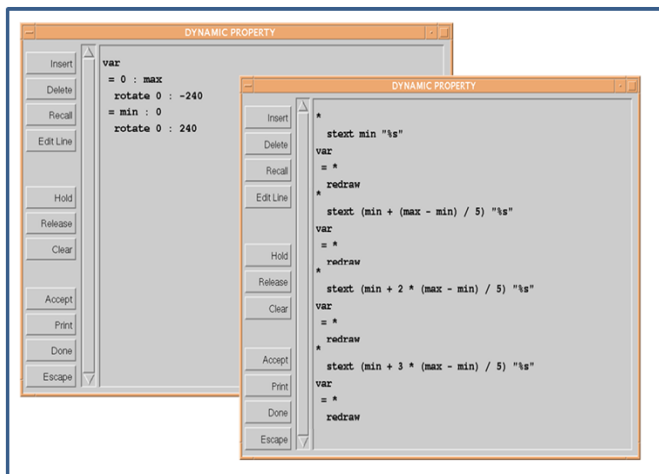

Fig- 7: Dynamic labeling and needle rotation logic

Emulated the function by means of rotor movement by needle 360 rotation, name representation for the state to communicate to the process logic, making contact by means of 0 or 1 to corresponding state variable and knob current state representation by changing the color of the state button (Refer fig-7). Emulated selector switches instance are integrated for the 12 sequential state selections for engaging and disengaging of CSR, 9

sequential state selections for engaging and disengaging of Diverse Safety Rod (DSR), 5 reactor operating state selections, triplicated safety channel selection, duplicated control channel selection.

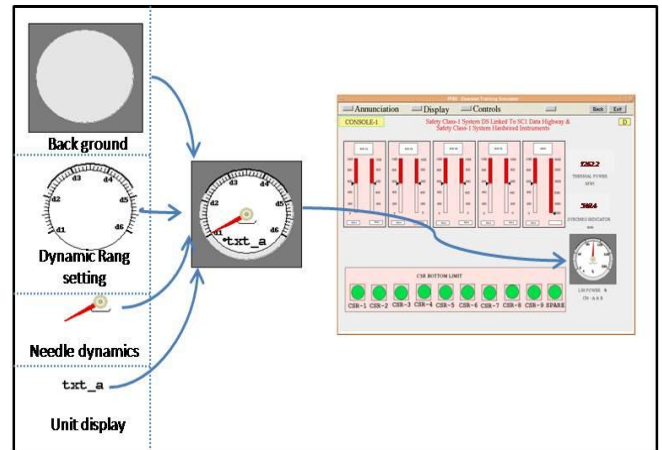

Fig-8 Emulation of Dial

7. DIAL

Dial is an important and basic instrument used in any power plant control room to accurately display the measured process parameters. Instrument has to receive the signal as voltage information and changes the needle position accordingly. This is the most challenging component to emulate with respect to the range distribution while configuring the instrument and the needle movement in real time in most accurate manner(refer fig-8).

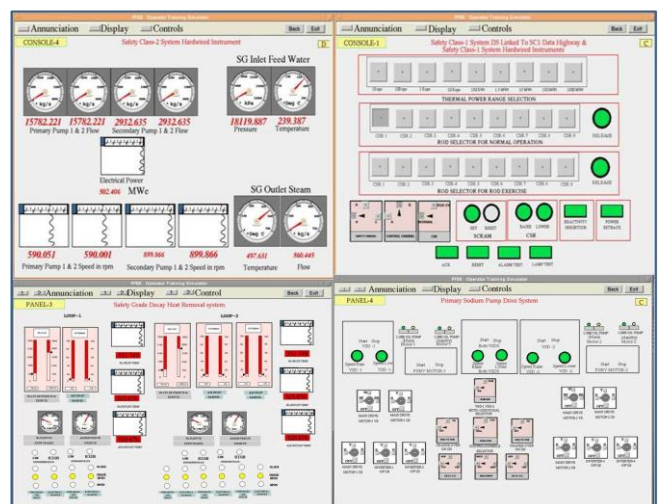

Fig-9 Virtual Panel Screens with emulated Instruments

8. RESULTS

Emulation of nuclear power plant instruments for operator training purpose is a most challenging job. An emulated instrument has been utilized for the virtual

panel simulation and it is emulated as per the panel requirement specification. Virtual panels are the primary soft screens to observe the dynamic of the simulated reference plant parameters for the operator training simulator development engineers for further tuning of the models (Refer fig-9).

9. CONCLUSION

Full scope PFBR operator training simulator is developed to provide training to the plant operators in all aspects from normal operation to all categories of events/transients. Training simulator platform has the one to one correspondent hardware panels so as to replicate the actual plant control room in all aspects specified to make the replica nature. For development and testing purpose virtual panels plays a key role to initiate and monitor the plant dynamics in line with the real hardware panel. The significant advance in the software technology has brought out cost effective and polished way of establishing real time virtual panel emulation for Full Scope operator Training Simulators. It helps the developer to have a smooth integration of the actual control panels after completion of development as well as verification and validation of the simulated models.

REFERENCES

- [1] Scope Document for PFBR Operator Training Simulator, T. Jayanthi, S.A.V. SatyaMurty, K.K. Kuriakose, S. Srinivasan, M.L. Jayalal, PFBR/08610/DN/1003/REV-A, IGCAR, 2007
- [2] Operator Training Simulator, T.R. Ellappan, S. Athinarayanan, PFBR/08610/DN/1000/REV-A, IGCAR, 2003
- [3] Training Requirements of PFBR Simulator, T. Jayanthi, S. Rajeswari, PFBR/08610/DN/1008/REV-A, IGCAR, 2008
- [4] Hardware Architecture of PFBR simulator, S.A.V. SatyaMurty, P. Shanmugam, Uma Seshadri, PFBR/08610/DN/1001/REV-B, IGCAR, 2005
- [5] Software Architecture of PFBR Simulator, R. Jehadeesan, M. L. Jayalal, PFBR/08610/DN/1002/REV-A, IGCAR, 2005

BIOGRAPHIES



H.Seetha received her B.E Degree from Bharathidasan University, T.N in 1997. She joined in Indira Gandhi Centre for Atomic Research (IGCAR) in 2001. She is currently a Scientific Officer-E in Electronics, Instrumentation and Radiological Safety Group-IGCAR. She has 14 Journal Publications / Conference Papers.



N.Jasmine received her B.E Degree from Anna University, T.N in 2007. She joined in Indira Gandhi Centre for Atomic Research (IGCAR) in 2008. She is currently a Scientific Officer-D in Electronics, Instrumentation and Radiological Safety Group-IGCAR. She has 7 Journal Publications / Conference Papers.



T.Jayanthi received her B.E (Hons) Degree Madras University, T.N in 1983. She joined in Indira Gandhi Centre for Atomic Research (IGCAR) in 1984, worked as a commissioning Engineer in FBTR and various other project in IGCAR. Presently function as Head of Simulator Section and working on Development and implementation of PFBR full scope operator training simulator and related research and development activities. She has more than 45 Journal Publications / Conference Papers / proceedings.



S.A.V Satya Murty received his B.Tech Degree from Jawaharlal Nehru Technological University, A.P in 1977. Later, he joined one year orientation course in Nuclear Science & Engineering (21st Batch) at Bhaba Atomic Research Centre (BARC)-Mumbai and then he joined in Indira Gandhi Centre for Atomic Research (IGCAR) in 1978. He is currently an Outstanding Scientist, Director of Electronics, Instrumentation and Radiological Safety Group-IGCAR. He has 110 Journal Publications / Conference Papers, 40 Internal Design Reports and edited two International Conference Proceedings.