

PERFORMANCE OF A BATTERY ELECTRIC VEHICLE WITH SELF CHARGING CAPACITY FOR ITS OWN PROPULSION

Suhas V¹, Sukeerth Calastawad², Phaneesh M³, Swaraj S⁴

¹ Student, Mechanical Department, Maharaja Institute of Technology, Karnataka, India

² Student, Mechanical Department, Maharaja Institute of Technology, Karnataka, India

³ Student, Mechanical Department, Maharaja Institute of Technology, Karnataka, India

⁴ Student, Mechanical Department, Maharaja Institute of Technology, Karnataka, India

Abstract - *The proposed work deals with a fabrication and testing of a battery electric vehicle with self-charging system for 2 passengers and for weight up to 250kgs. An attempt has been made to fabricate a self-charging battery electric vehicle which utilises the rotational energy of wheels to charge the batteries, thereby introducing a system which makes the vehicle pollution free. The fabrication of chassis is made for the similar dimensions of commercially available golf carts in market with some changes in its size and shape using C Channel type of Mild steel material. The components like alternator, motor and DC-DC converter was arranged in a manner to transfer the rotational energy being experienced by the MS bright rod to the alternator. The alternator here has the capacity to produce 12V to 14V, which is directed to DC-DC converter through a battery source. Here in DC-DC converter the voltage source is stepped up to 54V, which is enough to charge the 4 batteries in series which yields to 48V usage. Thus the batteries which are used to provide the rotational energy to the shaft through a motor is receiving back the sufficient voltage source to recharge it. The vehicle is tested for the supply of source to the batteries using multimeter, distance travelled with and without the recharging circuit is also studied and is found to be effective in its work.*

Key Words: *Battery Electric Vehicles, BLDC Motor, Alternator, Battery, and DC-DC Converter.*

1 INTRODUCTION

A self-propelled vehicle which is used in transporting people and goods from one place to another on road is called as an automobile. The early history of the automobile can be divided into a number of eras, based on the prevalent means of propulsion. At the turn of the 20th century electrically powered auto-mobiles appeared but

only occupied a niche market until the turn of the 21st century. Many have discussed regarding the continuous use of several energy sources from both fast depleting conventional energy sources. Their focus was on more economical, noiseless, emission free and uninterrupted alternate source of electricity named self-charging inverter [1]. An electric vehicle (EV), also referred to as an electric drive vehicle, uses one or more electric motors or traction motors for propulsion. Daan baker has discussed regarding that in coming years a few electric vehicles will emerge on the market that are powered by a rechargeable battery. The success of the battery electric vehicle (BEV) is very dependent on the battery technology [2].

Electric cars enjoyed popularity between the late 19th century and early 20th century, when electricity was among the preferred methods for automobile propulsion, providing a level of comfort and ease of operation that could not be achieved by the gasoline cars of the time. However, in recent years, increased concerns over the environmental impact of gasoline cars, higher gasoline prices, improvements in battery technology, and the prospect of peak oil, have brought about renewed interest in electric cars, which are perceived to be more environmentally friendly and cheaper to maintain and run, despite high initial costs, after a failed reappearance in the late-1990s. Electric vehicles, especially automobiles, are becoming popular and more prevalent due to increased energy costs and concern regarding the reduction of greenhouse gas emissions. Electric vehicles are powered by batteries that are contained with the vehicle and usually provide an adequate charge for the propulsion of the vehicle through city traffic. The batteries are mounted within the vehicle and are used to propel the car as an alternative to using an internal combustion engine. Even the earlier reviews of electric cars clearly stated that the electric car was ideal because it was cleaner, quieter and more economic means of transportation as opposed to the

internal combustion engine. Many have discussed regarding the major problems that are being faced today that is global warming and dwindling of the natural resources. Global warming is mainly due to the emissions of carbon-dioxide into the atmosphere. Transport Sector plays a major role in emission of carbon dioxide. It contributes to about 17-18% of the emissions of carbon dioxide. [3]

The modern electric car has been recently introduced as a hybrid where the vehicle is capable of operating on via electrical power or an internal combustion engine. Sreevalsan suggested Kinetic Energy Recovery System (KERS), a system for recovering the moving vehicle's kinetic energy under braking and also to convert the usual loss in kinetic energy into gain in kinetic energy. [4]

Some of the earlier designs of electric cars included a means to charge the vehicle using kinetic energy generated by the vehicle itself. The hybrid technologies allow for the use of electric propulsion at lower speeds and conversion to the internal combustion engine at higher speeds, therefore extending the drive time for the electric car. More recently, total electric cars are being introduced on the market to completely eliminate the use of internal combustion and make use of In-wheel motor system on rear wheels for small electric vehicle, the combination structure of each component. The key point of In-Wheel motor system to be applied in small electric vehicle is the integration capability to meet the requirements such as wheel space, power performance, strength of components [5]. Also, Dongbin Lu proposed a combined BLDC (brushless dc motor) and PMSM (permanent magnet synchronous motor) control for the hub motors. Sinusoidal control or field oriented control is applied for the hub motor at low speed, while block commutation algorithm is used at middle and high speed [6].

One drawback to electric cars is that batteries must be recharged and there are limitations in the range that the battery may propel the vehicle without recharging. One solution to this recharging problem is to have an interchangeable battery that may be replaced with the charged battery, similar to filling up a tank with gasoline. Faisal H. Khan presented a new technique to obtain isolated dc voltage outputs from a capacitor clamped dc-dc converter. The multilevel modular capacitor clamped converter (MMCCC) has several key features that make it possible to generate ac outputs (10 kHz) from a dc-dc

converter circuit. Using those high frequency ac outputs, the MMCCC circuit can incorporate single or multiple high frequency transformers to generate isolated ac outputs [7]. Such a device installed on a modern electric car may therefore increase the range of the battery and provide an effective means to recharge the battery while the vehicle is in motion.

1.1 BATTERY ELECTRIC VEHICLES

A battery electric vehicle (BEV) is a type of electric vehicle (EV) that uses chemical energy stored in rechargeable battery packs. BEVs use electric motors and motor controllers instead of internal combustion engines (ICEs) for propulsion.

The efficiency of an electric vehicle is far greater than all other forms of propulsion currently in use; also it offers the possibility of charging EVs from renewable energies. Whenever there is employment of electricity, the vehicles using it tend to produce zero emission at the tailpipe. Also, EVs offer great performance and are far from being slow. An electric vehicle operates differently from a vehicle with an IC engine. An all-electric vehicle is powered by electricity with a large rechargeable battery, an electric motor, a controller that sends electricity to the **motor from the driver's accelerator pedal, and a charging system**. These parts of an electric vehicle replace the IC engine, fuel tank, fuel line, and exhaust system in a traditional car. While the IC engine is central to the operation of a traditional vehicle, it is the rechargeable battery that is central to the operation of an electric vehicle. All-electric vehicles recharge their batteries by plugging them into a household electrical outlet or a special charging station. The major components used in existing battery electric vehicles are motors, motor controller and battery.

The advantages of a battery electric vehicle are like, it is cost effective, it is safe to drive, low maintenance, it has no emissions and there is no noise pollution when compared to that of an engine vehicle. Though having few advantages the battery electric vehicle has few drawbacks like short driving range and low speed, charging time for battery is more, less availability of recharge points.

2. OBJECTIVES

The objective of experimenting and fabricating the proposed vehicle is to revive the unused rotational energy of the wheels which is accomplished by using a DC synchronous generator leading to continued power generation thereby eliminating the concept of overnight charging of the batteries. The focus is to provide transportation facility for 2 members keeping the total weight as 250 kgs. The design is being considered so that **apart from 2 member's transportation the same vehicle can be used to travel patients within hospitals, old people (passengers) in railway station and can also be considered as a substitute for Golf karts.** The components being selected to develop this vehicle are cheaply available in market so that service, maintenance and replacement if any damages is easy for the customers. The defined work is to develop a self charging battery electric vehicle. The necessary amount of research papers and expert concern guided the way opt for the most optimistic method in selection of components, fabrication and testing of the vehicle under suitable conditions.

3. SELECTION OF COMPONENTS

Chassis frame: It is the frame wherein wheels machinery of motor vehicle, on which the body is supported. In the conventional chassis frames, the channel section of frame was considered because it has good resistance to bending and also lighter in weight when compared to box sections as per comparative is shown in Table 1 and 2.

Table 1: Weight/meter of box sections.

Designation	Weight/m Kg	Depth of section mm	Width of flange Mm
ISMC 75	7.14	75	40
ISMC 100	9.56	100	50
ISMC 125	13.1	125	65
ISMC 150	16.8	150	75

Table 2: Weight/meter of ISMC channel.

Dimensions in mm	Depth or width D in mm	Thickness in mm	Weight in Kg/m
180*180*4	180	4	21.9
180*180*5	180	5	27.2
180*180*6	180	6	32.05
180*180*8	180	8	42.5

From the above tables the weight per meter length of the channel and box sections, it is found that the weight of channel per metre length is about 7.14 kg when cross section is 75x40 mm when compared to box section which has a weight of 21.9 kg per meter length having a cross section of 180x180x4 mm, moreover channel section provides a bending resistance of 15 times greater than a box section with the same cross sectional area, hence from the above study channel section is selected as chassis frame for the defined work. The weight of frame has been calculated using the below equation:

$$\text{Weight of the frame} = \{2 \times \text{Height} + \text{Width} - 2 \times \text{Thickness}\} \times \text{Length (m)} \times \text{Thickness (mm)} \times \text{Density of the material (kg/cm}^3\text{)} \times 0.01$$

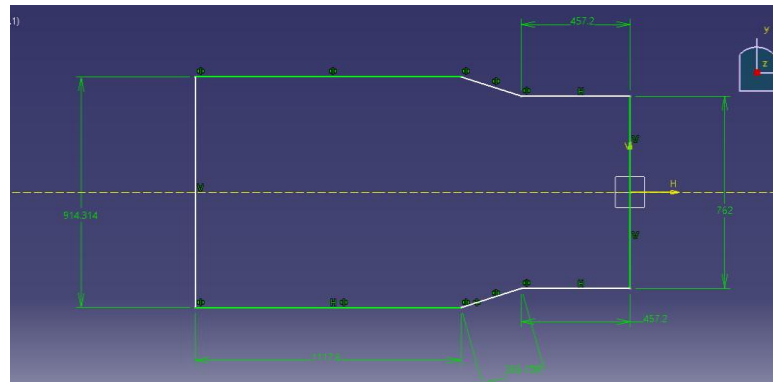

Fig 1: Outline of chassis frame
MS BRIGHT ROD AS SHAFT MATERIAL: Bright drawn mild steel is an improved quality material, free of scale, and has been cold worked (drawn or rolled) to size.

Table 3: Properties of a MS Bright rod

Chemical Composition of MS Bright rod		Mechanical properties of MS Bright rod	
Carbon	0.16-0.18%	Max Stress	400-560 N/mm ²
Silicon	0.40%	Yield Stress	300-440 N/mm ²
Manganese	0.70-0.90%	0.2% Proof Stress	280-420 N/mm ²
Sulphur and Phosphorus	0.040% each	Elongation	10-14%

Equations used for calculating shaft diameter:

1. Torsion of circular shaft = $\frac{\tau \cdot J}{r}$

Where J =Polar Moment of Inertia = $\frac{\pi d^4}{64}$

2. The angular deformation, $\theta = \frac{TL}{JG} \text{ rad}$

3. The torque transmitted by shaft, $T_s = \frac{9.55 \cdot 10^6 \cdot P}{N}$

4. ASME code for design of transmission shafting:

According to maximum shear stress theory

$$d_0 = \left[\frac{16}{\pi \tau_{max}} \left(\sqrt{((C_m M)^2 + (C_t T)^2)} \right) \cdot \frac{1}{1-K^4} \right]^{0.33}$$

Where, M= + ¼ F * l (end supports, centre load)

The equations used for key calculations are:

Key Material – EN8 (Unalloyed medium carbon steel)

According to DDHB for Square Keys,

1. The width of the square key $b = \frac{1}{4} d$ mm

2. Force acting on key $F_{key} = \frac{T}{d/2}$ N

3. Shear Area $A_s = W * L$ mm

BRUSHLESS DC MOTOR: DC electric motors (BLDC Motor) also known as electronically commuted motors, which are the motors which are powered by a DC electric source via an integrated inverter/ switching power supply, which provides an AC electric signal to drive the motor. In this context, alternating current does not imply a sinusoidal waveform. Additional sensors and electronics control the inverter output amplitude and waveform (and therefore

percent of DC bus usage/ efficiency) and frequency (i.e, rotor speed).



Fig 2: DC Motor

The equations for motor are,

1. Kinetic energy, $E = (1/2) \cdot m v^2$

Where m= mass of the vehicle

V= velocity of the vehicle

2. Braking distance, S

$$v^2 = u^2 + 2aS$$

3. Vehicle stopping time

$$v = u + at$$

4. Braking force, F

$$F = m \cdot a$$

5. Brake torque = brake force * effective radius of rotor

MOTOR CONTROLLER: A motor controller is a device or group of devices that serves to govern in some pre-determined manner the performance of an electric motor. A motor controller might include a manual or automatic means for starting and stopping the motor, selecting forward or reverse rotation, selecting and regulating the speed, limiting or regulating the torque, and protecting against overloads and faults.



Fig 3: Motor controller

BATTERIES: An electric battery is a device consisting of two or more electrochemical cells that convert stored chemical energy into electrical energy. Each cell contains a positive terminal or cathode and a negative terminal or anode. Electrolytes allow ions to move between the electrodes and terminals, which allows current to flow out of the battery to perform work.



Fig 4: Battery

ALTERNATORS: An alternator is an electrical generator that converts mechanical energy to electrical energy in the form of alternating current. For reasons of cost and simplicity, most alternators use a rotating magnetic with a stationary armature. Occasionally, a linear alternator or a rotating armature with a stationary magnetic field is used. In principle, any AC electrical generator can be called an alternator, but usually the term refers to small rotating machines driven by automotive and other internal combustion engines. An alternator that uses a permanent magnet for its magnetic field is called a magneto. Alternators in power stations driven by steam turbines are called turbo-alternators. Large 50 or 60 Hz phase alternators in power plants generate most of the world's electric power, which is distributed by electric power grids.

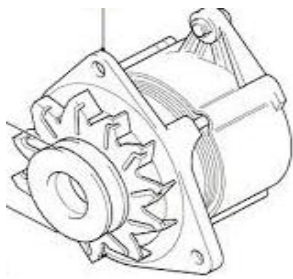

Fig 5: Alternator

The equations used for calculating the alternator speed and poles are:

1. No. of poles of alternator = $P = \frac{120 \cdot f}{N}$
2. Speed of Alternator = $N = \frac{120 \cdot f}{P}$

PULLEY: A pulley is a wheel on an axle or shaft that is designed to support movement and change of direction of a cable or belt along its circumference.



Fig 6: Fixed pulley

The equations used for pulley calculations are:

$$\text{Required speed} = 25 \text{ km/hr}$$

$$\text{We know that, } V = \frac{\pi \cdot D \cdot N}{60}$$

BELTS: A belt is a loop of flexible material used to mechanically link two or more rotating shafts, most often parallel. Belts may be used as a source of motion, to transmit power efficiently, or to track relative movement. The equations used for belt calculations are:

a) Alternator to shaft
 $D_e = d_p \cdot K_d$

b) Velocity, $V = \frac{\pi \cdot D \cdot N}{60}$

c) Speed calculations
 $\frac{N_1}{N_2} = \frac{D_2}{D_1}$

$$\frac{N_3}{N_4} = \frac{D_4}{D_3}$$

DC TO DC CONVERTER: A DC-to-DC converter is an electronic circuit which converts a source of direct current (DC) from one voltage level to another. It is a class of power converter. DC to DC converters are important in portable electronic devices such as cellular phones and laptop computers, which are supplied with power from batteries primarily. Such electronic devices often contain several sub-circuits, each with its own voltage level requirement different from that supplied by the battery or an external supply. Additionally, the battery voltage declines as its stored energy is drained.



Fig 7: DC-DC Converter

Magnetic conversion method: In these DC-to-DC converters, energy is periodically stored into and released from a magnetic field in an inductor or a transformer,

typically in the range from 300 kHz to 10 MHz. By adjusting the duty cycle of the charging voltage (that is, the ratio of on/off time), the amount of power transferred can be controlled. Usually, this is applied to control the output voltage, though it could be applied to control the input current, the output current, or maintain a constant power. Transformer-based converters may provide isolation between the input and the output.

STEERING SYSTEM: It is a system that provides the directional change in the movement of an automobile and maintain in a position as per the driver's decision without much strain on him.

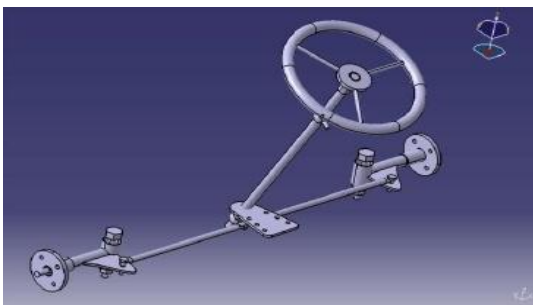

Fig 8: Steering system

Calculations on steering

1. Ackerman steering angle, α

$$\tan \alpha = (\text{track width} / 2) / \text{wheelbase}$$

2. Condition for perfect rolling

$$\cot \phi - \cot \theta = c/b$$

Where, ϕ = angle of outside lock

θ = angle of inside lock

3. Radius of inner front wheel

$$R_{IF} = (b/\sin \theta) - ((a-c) / 2)$$

4. Radius of outer front wheel,

$$R_{OF} = (b/\sin \phi) + ((a-c) / 2)$$

4. DESIGN OF CHASSIS FRAME

The figure shows the engineering drawing of the chassis frame which has been designed based on the maximum loading force that is exerted on the rear part of the vehicle.

The value of pressure obtained is applied as a condition on the chassis frame using CATIA V5 R20 software and the analysis results are obtained in the form of von-misses stress and displacement plot as shown below figure 9 and 10.

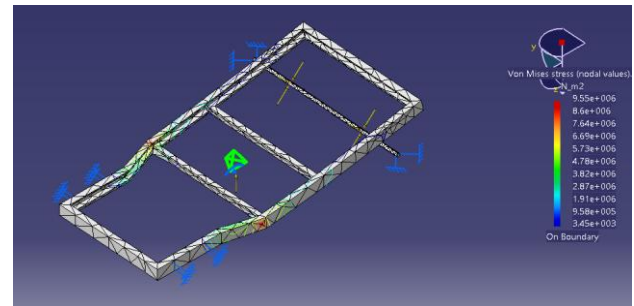

Fig 9: Von misses stress analysis

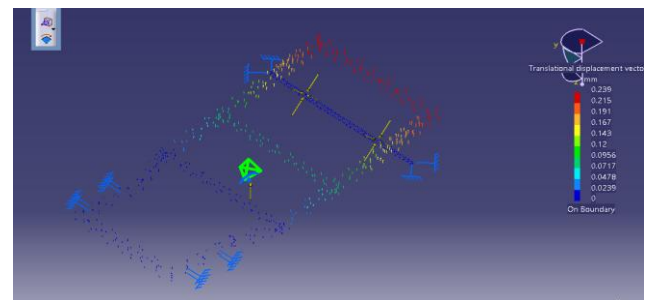

Fig 10: Translational displacement analysis

5. INTERCONNECTIONS AND WORKING

In operation, the BLDC hub motor is driven by set of 4 drive batteries which are connected in series and provide an output voltage and current of 48V and 28Ah respectively which acts as the power train. The motor which is connected to the pulley through a belt drive system propels the vehicle and henceforth acts as a drive train. As the vehicle begins to move, the pulley keyed to rear axle connected to the alternator spindle through a belt begins to rotate, this in turn causes the alternator pulley to rotate, which disturbs the magnetic flux being produced thereby generating the voltage and current which is diverted towards a charging battery of 12V, 7Ah capacity. To this battery is connected a 12-54V DC-DC converter whose function is to step up the 12V from charging Battery to 48V which is given to the set of 4 drive batteries which is connected to the motor and henceforth the cycle repeats and is shown in figure 11.

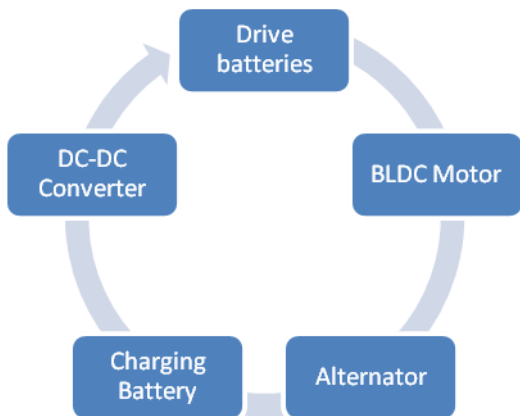

Fig 11: Working cycle

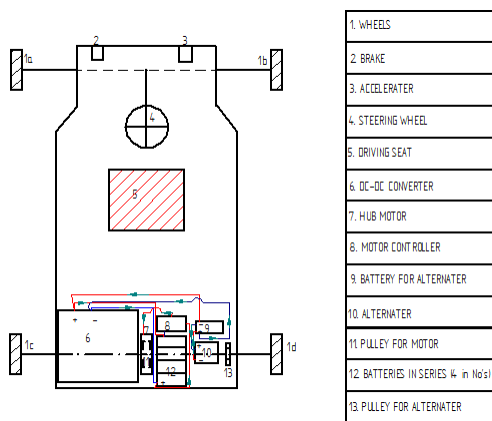

Fig 12: Allocation of components

6. RESULTS AND DISCUSSION

The battery electric vehicle based on the required considerations is made ready with all connections and support on the chassis frame. The outcome of the vehicle was expected to supply the source continuously to charge the battery when the vehicle is moving forward. The connections made so far, provided the supply source based on the need and it is observed in many numbers of trials. A set of 4 Lead acid batteries with specifications as 12V and 7Ah is used in the work. The supply from these batteries is found to be useful in moving the vehicle for a distance of around 4 km. During the course the rotational energy is extracted by an alternator and transferred to a DC to DC converter where it is stepped up. This is finally supplied to battery source to recharge making it as a closed circuit.

The power source which is expected to reach the battery source from the alternator through DC-DC converter is observed using Multimeter. The parameter to be considered during the test, are voltage source and ampere.

The comparison made on various numbers of trials in the defined closed circuit is shown in Table 4.

Table 4 Input output results

Trials	Input from alternator to charging battery		Output from charging battery to DC-DC converter		Output from DC-DC converter to drive batteries	
	V	A	V	A	V	A
1.	12.9	0.3	12	4	54	1
2.	13.2	0.3	12	4	54	1
3.	12.8	0.3	12	4	54	1
4.	13.1	0.3	12	4	54	1
5.	13.0	0.3	12	4	54	1

The graph has been plotted for varying loading conditions and for different speeds of the vehicle where the x-axis represents the speed in km/hr and y-axis depicts the distance travelled in km.

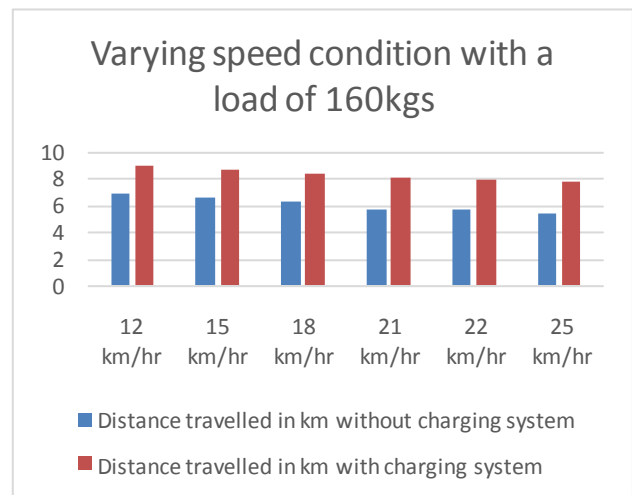

Fig 13: Distance comparison graphs with load of 160kgs.

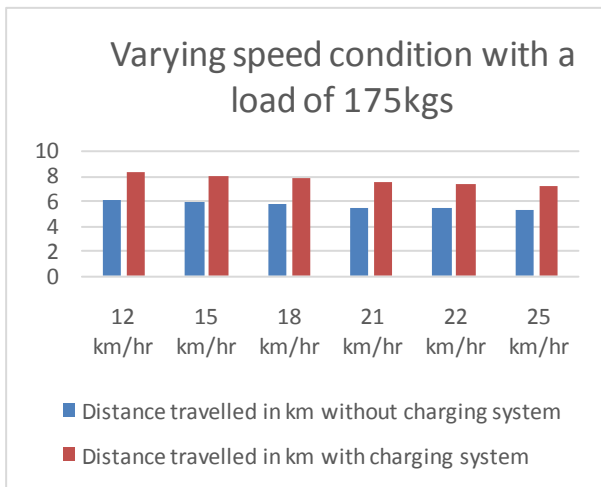

Fig 14: Distance comparison graphs with load of 175kgs.

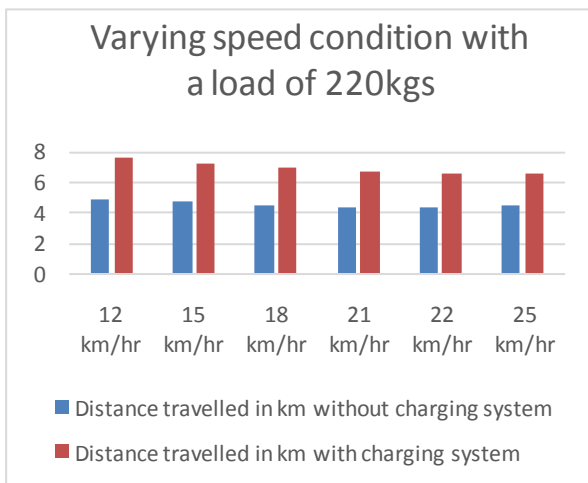

Fig 15: Distance comparison graphs with load of 220kgs.

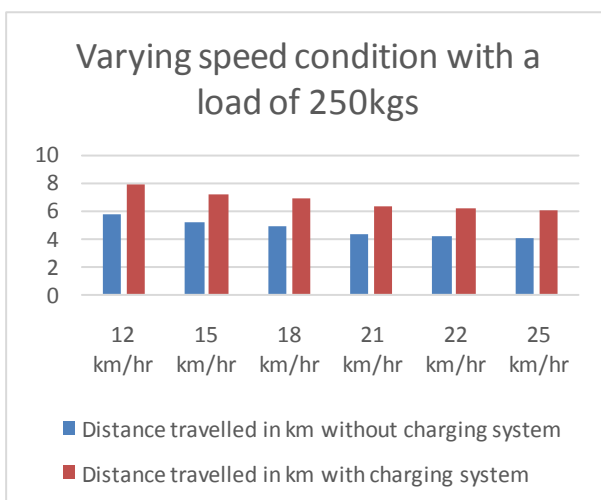

Fig 16: Distance comparison graphs with load of 250kgs.

7. CONCLUSION

The work is defined to develop a battery electric vehicle for closed circuit areas like railway station platforms, Golf clubs, hospital corridors, industries etc. The concept of plug in charging which is found in conventional battery electric vehicles was targeted to replace by the concept of self charging in the defined work. The work started with the study on technology, components utilization and the future of battery electric vehicles. Based on the study the outline of the electric vehicle was framed to carry 2 passengers or a weight of 250 kg.

The alternator system, motor, motor controller, DC-DC converter was considered in the work based on their extensive use in the field of automobiles. From the plotted graphs we can conclude that the vehicle travels for longer distance when the charging system has been adopted. The vehicle was tested for the source supply from the DC-DC converter to the batteries for many numbers of trials. This depicted the successful results in extracting the rotational energy from the wheels through an alternator to charge the batteries arranged in series. The alternator used in the work was successful in generating 12V – 14V using the rotational energy from the wheels under forward motion. The DC-DC converter steps up the source from 12V DC to 54V DC, which results in charging the batteries used for the work.

REFERENCES

1. Abatan O.A, Adewale A.O, Alabi A.A, Constant Electricity Generation From Self- Charging Inverter, IJETAE ISSN 2250-2459, ISO 9001:2008 Certified Journal, Volume 3, Issue 12, December 2013.
2. Daan Bakker, Battery Electric Vehicles - Performance, CO2 emissions, lifecycle costs and advanced battery technology development, Sustainable Development, Energy and Resources, Copernicus institute University of Utrecht, August 2010.
3. Faisal H. Khan, Leon M. Tolbert, "5 kW Multilevel DC-DC Converter for Hybrid Electric and Fuel Cell Automotive Applications".
4. Sreevalsan S Menon, Sooraj M S, Sanjay Mohan, Rino Disney, Suneeth Sukumaran, Design and analysis of kinetic energy recovery system in bicycles, IJRSET, ISSN:2319-8753, Vol.2, Issue 8, August 2013.
5. Donghyun Kim, Kyeongho Shin, Youngkwang Kim and Jaeseung Cheon, Integrated Design of In-Wheel Motor System on Rear Wheels for Small Electric Vehicle, World Electric Vehicle Journal Vol. 4 Pg000597- ISSN 2032-6653 - © 2010 WEVA.
6. Dongbin Lu, Jianqiu Li, Minggao Ouyang and Jing Gu, "Electric Vehicles using hub motors", Vehicle Power and Propulsion Conference (VPPC), 2011 IEEE.
7. D.J. Van Schalkwyk and M.J. Kamper., "Effect of Hub Motor Mass on Stability and Comfort of Electric Vehicles".

8. "Design Data Handbook Third Edition" by K.Mahadevan and K.Balaveera Reddy.

9. "Design of Machine Elements 2" by J.B.K. Das and P.L. Srinivasa Murthy.

BIOGRAPHIES



Suhas V,
Student, Mechanical
engineering department,
Maharaja Institute of
Technology Mysore.



Sukeerth Calastawad,
Student, Mechanical
engineering department,
Maharaja Institute of
Technology Mysore.



Phaneesh M,
Student, Mechanical
engineering department,
Maharaja Institute of
Technology Mysore.



Swaraj S,
Student, Mechanical
engineering department,
Maharaja Institute of
Technology Mysore.