

# An Enhancement in EEM-LEACH Protocol Based on Honey Bee Optimization (HBO) technique for WSN

<sup>1</sup>Akashdeep Chaudhary, <sup>2</sup>Malti Rani

<sup>1</sup>akashdeep2589@gmail.com, <sup>2</sup>malti\_87@yahoo.co.in

<sup>1</sup> M.tech Student, CSE, PITK, PTU Main Campus, Punjab, India

<sup>2</sup>Assistant Professor, CSE, PITK, PTU Main Campus, Punjab, India

\*\*\*

**Abstract** -A wireless sensor network is a network consisting of various nodes connected to each other in wireless fashion. It has been an area which is making a contribution in the sensing technology worldwide. Limited battery has been the most concerning issue in dealing with sensor nodes, as these batteries once deployed can't be replaced. In order to make communication among nodes much effective, various routing strategies have been incorporated. There are various routing protocols developed for the same purpose. In this paper, the work is focused to optimize the hierarchical clustering routing protocol to enhance the network lifetime. The optimization technique is Honey Bee Optimization which is being used here for the cluster head selection. Simulation being performed in MATLAB shows that HBO-Optimized protocol shows much better results than the EEM-LEACH protocol. This protocol is much favorable to the large scale application area.

**Key Words:** Wireless Sensor Network (WSN); LEACH (Low Energy Adaptive Clustering Hierarchy); EEM-LEACH (Energy Efficient Modified-LEACH); M-LEACH (Modified Leach).

## I. Introduction to Wireless Sensor Network

With the passage of time, the sensing technology is all over the world it has become possible because due to recent technological advances, the manufacturing of small and low-cost sensors has become technically and economically feasible. Wireless sensor networks (WSNs) comprises of small nodes with sensing, computation, and wireless communications capabilities [1].

These networks are mainly to be used for the systematic gathering of useful information related to the surrounding environment (e. g. temperature, humidity, seismic and acoustic data, etc.), and for the transmission of the gathered data to a base station, i. e. sink, for further processing. Architecture of Wireless Sensor Network is shown in Figure 1.1

Military applications demanded the development of WSN, application includes battlefield surveillance. Various industrial and civilian applications make the best use of wireless sensor network. Even habitat monitoring is an area which is heavily explored by the WSN [2].

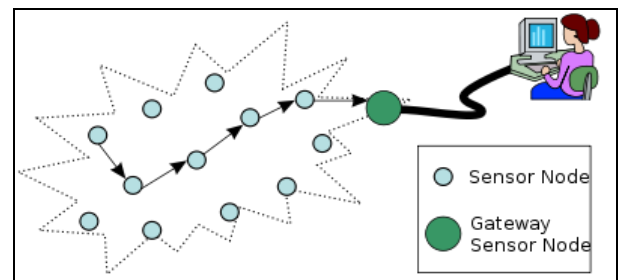

Figure 1.1 Wireless sensor network architecture [2]

The most concerning issue in sensor network has been the limited battery life. The communication cost is being heavily paid by the communication among the nodes and sink. So there have been various research activities in the direction of making the routing much efficient.

Various routing protocols have been developed to achieve the maximum lifetime of the network [3-4]. LEACH has been the first clustering protocol who is hierarchical clustered protocol, selects cluster head on the random basis. Since then various variants of clustering protocols have been developed to counter the limitations of previous ones [5].

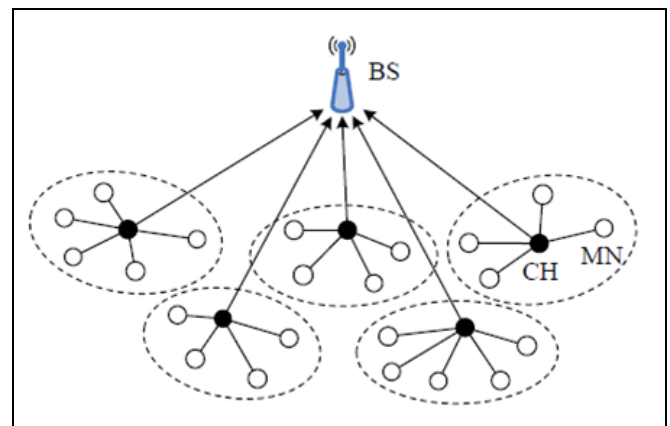

Figure 1.2 LEACH protocol [6]

In this paper, the focus has been on the optimization of routing protocol which is based on clustering. EEM-LEACH has given much improved lifetime as compare to M-LEACH which is being shown in Figure 1.3.

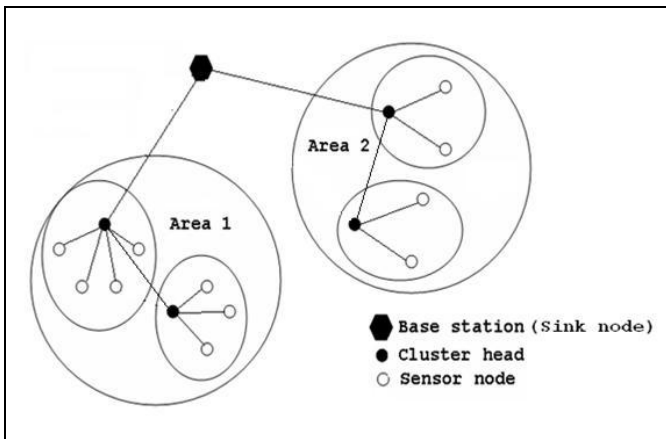

Figure 1.3 M-LEACH protocol [7]

The optimization techniques do find their best utility in the selection of cluster head. These optimization techniques are nature inspired and give the optimized solution. These include Honey Bee Optimization, Ant Colony Optimization, Particle Swarm Optimization and many more. In this paper, the work is focused on the implementation of Honey Bee Optimization for the selection of cluster head in the EEM-LEACH protocol to make it much more efficient.

This paper is organized further as follows: section 2 covers the introduction to Honey Bee Optimization Technique, EEM-Protocol is covered in section 3 and then the proposed protocol is explained in section 4. Conclusion and Future scope are given in section 5 along with references in section 6.

## II. Introduction to Honey Bee Optimization

A honey bee colony extends themselves over long distances in multiple directions in order to achieve large number of food sources. The foraging process starts in a colony by sending the scout bees to search for the promising flower patches. There is a random movement of scout bees from one patch to another.

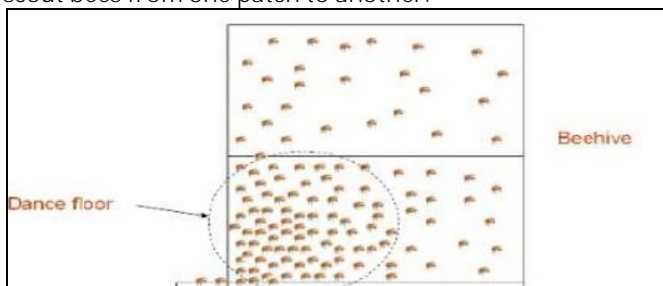

Figure 2.1 Natural behavior of honey bee

When the scout bees return to the hive, they found a patch which is measured above a certain quality threshold and deposit their pollen or nectar and then they move to the dance floor to perform the waggle dance. The waggle dance is for colony communication and it contains the information of flower patch i.e. the direction in which the

patch is found, distance of flower patch from hive and its quality fitness.

This information is useful for sending the bees to the flower patches without using maps. The waggle dance enables the colony to determine the fitness of various patches according to the food quality and amount of energy required to harvest it. After the waggle dance, the scout bee moves back towards to the flower patch with other bees i.e. follower bees that were waiting inside hive. Then more follower bees are sent to the more promising patches which allow the colony to gather the food more efficiently and quickly. The bees monitor the food level while harvesting from the flower patch. This is important to decide the next waggle dance when they return to hive.

## III. EEM-LEACH

EEM-LEACH discovers a multi hop path with minimum communication cost from each node to the base station as shown in Figure 1.3. If the communication cost for direct data transfer is minimum, nodes close to the base station can send data directly to the base station thereby preventing them from dying soon. Only nodes with maximum residual energy and minimum energy consumption can become cluster heads since each node's residual energy as well as average energy consumption is considered for the selection of cluster heads.

$$T_{(n)} = \frac{P_i}{1 - P_i * (r \bmod \frac{1}{P_i})} \times P(RE) \text{ if } n \in G$$

Else  $T_{(n)} = 0$  otherwise

The simulation results clearly shows that the proposed protocol gives a better lifetime, minimized energy consumption and good packet delivery than the protocols of Leach and M-Leach.

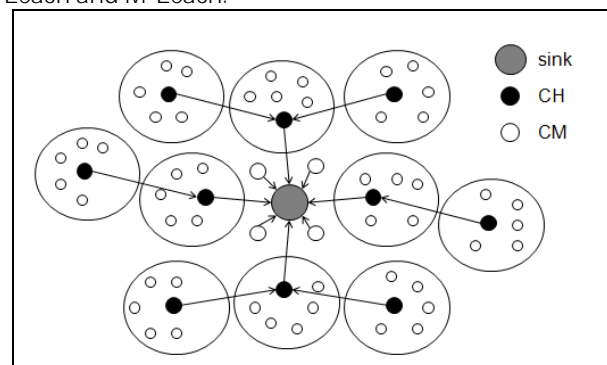

Figure 3.1 EEM-LEACH protocol [8]

## IV. Proposed HBO Based EEM-LEACH

The proposed protocol aims to enhance the network lifetime. It follows these steps to implement the proposed technique of incorporating the two cluster heads in a cluster.

- a) Initialization of parameters
- b) Network Formation

- c) Selection of Cluster head on the Basis of HBO technique. Data Transmission
- d) Simulated Results

a) Initialization of parameters : The very first step while simulating the proposed technique is to initialize the simulation parameters that defines the size of network, number of nodes, energy of nodes that are to be deployed along with the energy requirement for the aggregation of data and transmission and reception of data.

Table 1: Simulation parameters

Parameter	Value
Area of network	100m X 100m, 500m X 500m
Packet size	512 bytes
Number of nodes	200, 1000
Position of sink	(50m,50m), (250m X 250m)
Initial energy	0.1J
$E_{elec}$	50nJ/bit
$E_{Rx-elec}$	50nJ/bit
$E_{amp}$	0.0013pJ/bit/m <sup>2</sup>
Transmission Range	100m
Desired % of cluster head	5%
Energy for data fusing	5nJ/bit

b) Network Formation

The proposed protocol works in two network scenario:

1. 100m X 100m with 200 nodes with sink deployed at (50, 50)
2. 500m X 500m with 1000 nodes with sink deployed at (250,250)

After initialization of simulation parameters, the sink is deployed for the two network scenario as mentioned above. One case is observed for the small network and the other one is for the large area network.

c) Selection of Cluster Head with the use of HBO technique.

In this the Cluster Head is selected on the basis of HBO technique. HBO technique gives the fitness value in the basis of distance from the Base Station and energy of the node. The optimized solution is found out which selects the cluster head. This is done through the analogy which is explained as:

Scout bee gives the fittest value through the waggle dance, which evaluates the bees in the hive for this fitness factor. Analogy to the sensor network can be explained in the way

that fitness value is determined by calculating the distance from the Base Station and energy of the node which is distance of bees from the most nutrient flower patch and quality of fitness is analogous to the energy of node.

d) Data Transmission

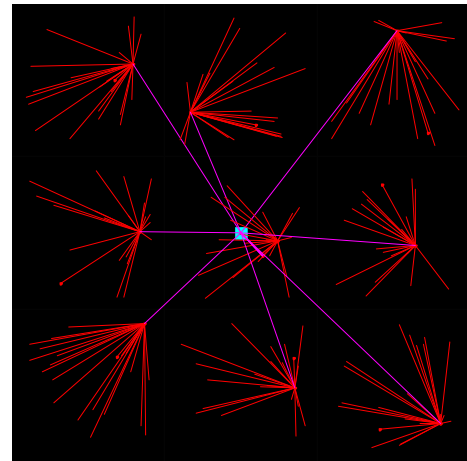

Fig. 4.1 Data transmission in the network with 200 nodes

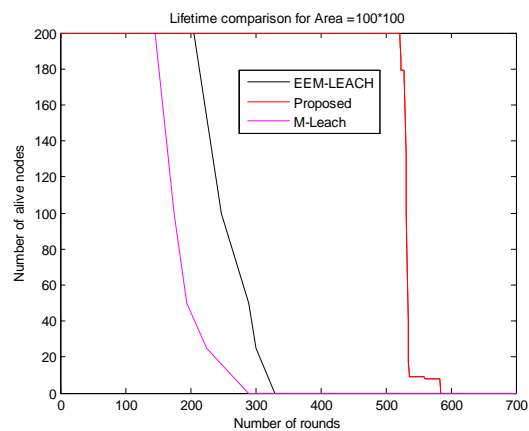

Fig.4.2 Lifetime comparison of proposed technique with EEM-LEACH and M-LEACH

the proposed technique with the existing recent techniques of EEM-LEACH and M-LEACH. The proposed technique covers 520 number of rounds before the first node dies which was only 205 in case of EEM-LEACH and 146 in case of LEACH. So, FND has increased by 153% from the EEM-LEACH. This much of improvement in the EEM-LEACH is due to load balancing in the network. Similarly All Node Dead (AND) occurs at 580 rounds which was 330 in case of EEM-LEACH accounting the enhancement by 77%.

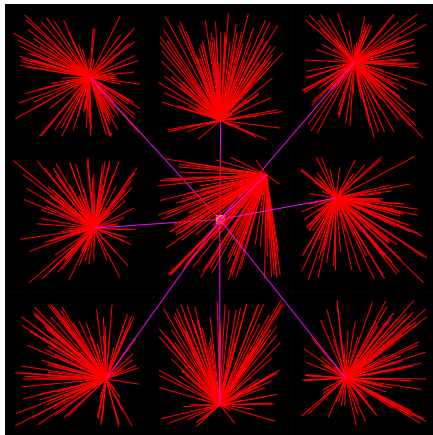

Fig. 4.3 Data transmission in the network with 1000 nodes

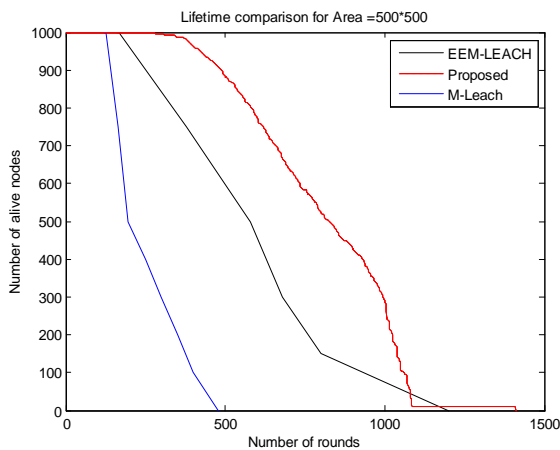

Fig. 4.4 Lifetime comparison of proposed technique with EEM-LEACH and LEACH with areas 500X500 and 1000 nodes

The proposed technique covers 260 number of rounds before the first node dies which was only 205 in case of EEM-LEACH and 146 in case of LEACH. So, FND has increased by 87% from the EEM-LEACH. This much of improvement in the EEM-LEACH is due to load balancing in the network. Similarly All Node Dead (AND) occurs at 1410 rounds which was 1200 in case of EEM-LEACH accounting the enhancement by 17.5%.

## V. Conclusion:

It has been observed that cluster head selection is one of the most significant aspects where the aim of making the network energy efficient and enhancing the lifetime of nodes can be achieved. In that prospective, in the proposed technique, HBO optimization is being incorporated. HBO optimization helps in finding out the fitness value which is determined through the two parameters of distance from the Base Station and the remaining energy of node in the network. Two scenario of different area network are considered. One is 100mX 100m with 200 nodes, which when simulated in MATLAB

gives the optimized selection of cluster head by giving 153% improvement in EEM-LEACH. Last Node Dead is achieved with improvement of 77%. The other scenario in which the network area is 500m X 500m in which the improvement of 87% is observed from EEM-LEACH. HBO Optimization also helps in enhancement of number of rounds for the Last Node Dead which accounts for the 17.5% improvement. So it can be concluded that with the such increase in the number of rounds, HBO Optimization really works so efficiently that it can favors to the various large scale applications.

## VI. References

- [1] I.F. Akyildiz, W. Su, Y. Sankarasubramaniam, E. Cayirci "A Survey on sensor networks," IEEE Communication Magazine, pp. 393-422, 2002.
- [2] Kemal Akkaya, Mohamed Younis "A survey on routing protocols for wireless sensor networks," IEEE Communication Magazine on Ad Hoc Networks, pp. 325-349, 2005.
- [3] Shio Kumar Singh 1, M P Singh 2, and D K Singh "Routing protocols in Wireless Sensor Networks – a Survey," International journal of computer science & engineering survey (IJCSES) Vol.1, No.2, pp. 63-83, 2010.
- [4] F. Ye et al., "A Scalable Solution to Minimum Cost Forwarding in Large Sensor Networks," Proc. 10th Int'l. Conf. Comp. Commun. and Networks, 2001, pp. 304-09.
- [5] C. Schurgers and M.B. Srivastava, "Energy Efficient Routing in Wireless Sensor Networks," MILCOM Proc. Commun. for Network-Centric Ops.: Creating the Info. Force, McLean, VA, 2001.
- [6] W. Heinzelman, J. Kulik, and H. Balakrishnan, "Adaptive Protocols for Information Dissemination in Wireless Sensor Networks," Proc. 5th ACM/IEEE Mobicom, Seattle, WA, pp. 174-85, Aug. 1999.
- [7] F. M. Omer, D. A. Basit, and S. G. Asadullah, "Multi-hop Routing with Low Energy Adaptive Clustering Hierarchy," IEEE conference on Sensor Technologies and Applications (SENSORCOMM), pp. 262-268, 2010
- [8] Ashlyn Antoo, Rameez Mohammed A, "EEM-LEACH: Energy Efficient Multi-hop LEACH Routing Protocol for Clustered WSNs," IEEE International Conference on Control, Instrumentation, Communication and Computational Technologies (ICCICCT) pp.812-818, 2014.