

Reducing the cycle time in fabrication of bucket in wheel loader, by designing a welding fixture

DARSHAN S¹, G S PRAKASH², JAGADISH MOGAVEERA B³,

¹ Research scholar, Industrial Engineering & Management, MSRIT, Karnataka, India

² Professor & HOD, Industrial Engineering & Management, MSRIT, Karnataka, India

³ Asst Manager, Support Services- Fabrication, L & T Construction Equipment, Karnataka, India

Abstract: The challenge in today's competitive market is to be on the leading edge of producing higher quality products at minimum cost and deliver the products to customer at right time. Thus the fabrication shop needs to fabricate the products at a defect free rate and thus deliver to their immediate customer assembly shop. Various areas related to design of fixture are already been very well described by various renowned authors, but there is need to integrate & apply all these research work to an industrial application. This paper focuses all these aspects. A loader is a type of tractor, usually wheeled, sometimes on tracks, that has a front-mounted square wide bucket connected to the end of lift arm. A loader is commonly used to move a stockpiled material from ground level and deposit it into an awaiting dump truck.

There are no jigs and fixtures available. Keeping this as the main objective, to improve the fabrication activities for smooth production is highly prioritized. The project is carried out to design a welding fixture for wheel loader BUCKET to reduce the cycle time, by using auto cad (2d) design tool. Fixture is designed by considering all the critical to quality (CTQ) parameters.

Key Words: welding fixture, critical to quality (CTQ)

1. INTRODUCTION

L & T is a leading manufacturer of hydraulic excavators. **The challenge in today's competitive market is to be on the leading edge of producing higher quality products at minimum cost and deliver the products to customer at very less lead time.** Thus the fabrication shop needs to fabricate the products at a defect free rate and thus deliver to their immediate customer assembly shop.

Wheel loader is the new product launched by L & T construction equipment limited. Presently all the parts are manufacturing using first principle of engineering. There are no jigs and fixtures available. Keeping this as the main objective, to improve the fabrication activities for smooth production is highly prioritized. The project is carried out to design a welding fixture for wheel loader BUCKET to reduce the cycle time.

Wheel loader has three variants; 1.7cum, 2.0cum, 3.0cum. Currently wheel loader bucket is manufactured using first principle of engineering, where all measurements are done manually & positioning or fixing of each component takes lot of time.

Critical components in wheel loader bucket are, welding of side orials, centre orials & side plate assembly

2. Problem definition

The reason to take up this project is considered with respect to the process improvement by designing a fixture for bucket in wheel loader

Presently there are no fixtures for lift arm & bucket of a Wheel loader 9020 this is otherwise being welded by using hoist hook carriers and rotated to desired positions **every time by cranes which leads to high 3m's (money, men, machine)** and increases manufacturing lead time and extremely unsafe.

The problems encountered in the present processes are:

- Tack welding of bucket is done by using first principle of engineering
- All measurements are done manually for each sub-assembly
- Positioning of each sub-assemblies increases the cycle time
- Maintaining the straightness while fixing ear BKT & ear link is time consuming

3. FIXTURE

A fixture is a device used for holding the work piece during machining operations or during welding process. It does not have provision to guide the tool as that of a jig. But it is always fastened to a machine table in a fixed position. Most of the machining operations can be performed by clamping the work piece directly on to the machine table without using a fixture, when only a few parts are to be machined. But when the number of parts is large enough to justify the cost of fixture, it is generally used for holding and locating the work piece. The aspect of clamping is

given more emphasis in fixture's design, as the clamping force should be able to withstand the cutting force. The fixture deploys setting blocks to locate the cutter properly in relation to the fixture or the components. It is not always required to have blocks as in the case of turning or welding fixtures. The fixture should be clamped to the table of the machine upon which the work is to be done.

3.1. Essential features of idle fixture

- Reduction of idle time: the design of fixtures should be such that the process of loading & unloading the components takes the minimum possible time & enables an easy location & clamping should be such that idle time is reduced to minimum
- Replaceable parts or standardization: the locating & supporting surfaces as far as possible should be replaceable that is not permanently fastened. When worn out new once may replace them. Moreover they should be standardized. So that their interchangeable manufacture is possible.
- Economic soundness: the equipment to be used should be economically sound. i.e. the cost of its designing its manufacturing should be in proportion to the quality & the price of the producer
- Position & clamps: the clamps should be so positioned that clamping occurs directly above the points supporting the work piece so as to avoid distortion & springing of work which otherwise will result in an accurate work. Moreover the clamp should be strong enough to resist bending clamping pressure
- Safety: The design of fixture should be such that it should not constitute any danger to the operator.

3.2. Principles of welding fixtures:

A few design principles applicable only to welding fixtures are given below.

- The heat produced during welding will result in the expansion of work piece. Due to this the proper location, clamping, locating, loading & unloading should not be affected.
- Welding spatter should not be allowed to fall on the threaded parts of the clamping elements.
- It should not be so designed that it does not get overhead due to continuous work.
- As far as possible, the fixture should be designed that all welding in one setting..
- Clamps should be kept clear of welding zone or be shielded. The removal of work piece from the fixture should be as easiest as possible after welding.

- Location & clamping should not make the welding zone inaccessible.
- The base plate of the fixture is milled with grooves below the welding area to provide positive clearance between work piece & the base.
- There should be proper clearance between the work piece & locator to permit expansion.

4. METHODOLOGY

Organization looks for ways to continuously improve their process, production and quality of the out produced. This requires various techniques and tools to be utilized for reduction of production cost and increase their productivity.

- Data collection
- Analysis & development solution
- Fabrication
- Implementation
- Inspection & proving
- Result & conclusion

Project objectives

- 1) Reduce the manufacturing Lead time of the Wheel loader
- 2) Reduce the Inspection & maintain dimensional accuracy and Quality of the Wheel loader
- 3) Reduce the operator fatigue
- 4) Increase Productivity

4.1. Welding fixture for bucket:

Isometric view

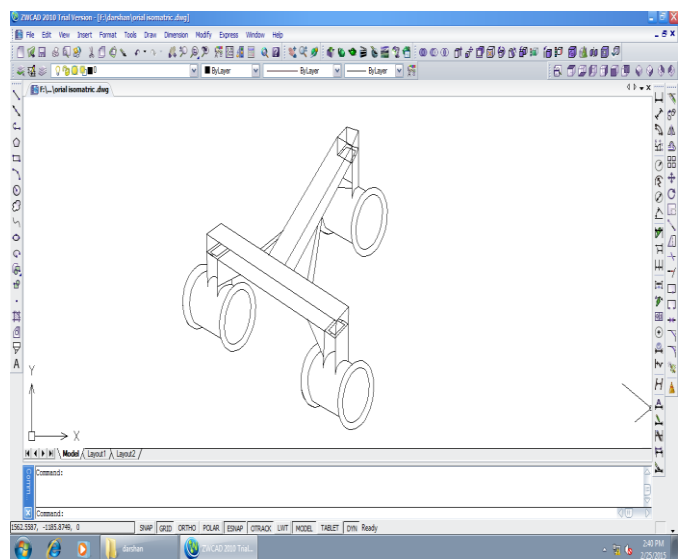

Top & side view

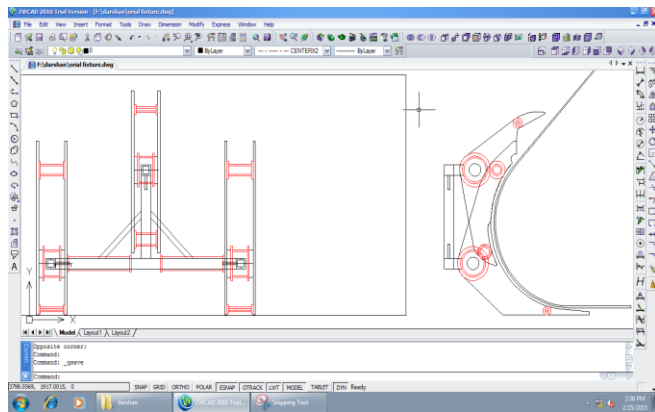

5. CONCLUSION

The design of fixture is simple, loading & unloading of component is very easy. This fixture helps to hold the work piece firmly during welding operation. It is designed in such a way that it fits all three variants of wheel loader bucket. For orials separate template is designed using gap gauge, which reduces the multiple operations. Distortion during welding can also be reduced. Using this fixture structural machining can be avoided. This reduces the machining time from 7.33hours to 1 hour.



DARSHAN S
M-Tech (IEM)
MSRIT, BENGALURU



Dr G S PRAKASH
Professor & HOD
MSRIT, BENGALURU

Fixture for shell & side plate assembly

