

Controlling of different electronic devices by RC5 remote

Sowjanya M N¹, Bettisha Baby Thomas², Kavana.J³, Pooja B S⁴, Prathima R⁵

¹ Assistant Professor, Dept of IT, GSSSIETW, Karnataka, India

^{2,3,4,5} UG Students, Dept of IT, GSSSIETW, Karnataka, India

Abstract - Generally Technology is developing very fast and providing more advantages to human life, and the electronic devices are very easy to handle and operate. The physically disabled people require home automation systems which are user friendly too. To provide a good automation system we switch to controlling of electronic devices using low cost simple rc5remote which is based on the MSP430 Microcontroller. The input signal is sent from the remote whenever the key is pressed in the remote, the IR signal from the remote is received by IR sensor which is present on booster pack and the IR data is sent to the microcontroller, the microcontroller decodes the IR data and turns ON the particular device which is configured for particular input. For the particular key the respective device turns ON. The devices can also be switched ON/OFF by the capacitive touch sensor or touch pad which is mounted on the booster pack.

Key Words: RC5 Protocol, IR Sensor, MSP430 Microcontroller, Booster pack, IAR workbench

1. INTRODUCTION

Automation is the delegation of human control functions to technical equipment. Automation of any system can be achieved by making the system smart. The purpose of this project is to provide a generic solution for implementing an IR receiver in software using MSP430 microcontroller. The main problem in home automation is user cannot operate different devices using single switch. This problem can be reduced by using a single rc5remote. Therefore any physically disabled people can operate their home appliances on their own making them independent. Thus it provides a user friendly environment to user.. In our project we use rc5remote to operate only six electrical equipment. primarily concentrate on showing how RC5 protocol can be used for home automation system. This design of RC5 protocol based remote control using MSP430 Microcontroller is based on IR signals, that IR signals is transmitted by remote that signal is received by

the IR sensor and those signals is controlled by the MSP430 Microcontroller and gives immediate result by switching ON/OFF the corresponding electrical devices. The devices can also be switched ON/OFF by the capacitive touch sensor or touch pad which is mounted on the booster pack. The advantages of automation are 1. Reduce the manpower, 2.Increases efficiency and accuracy.

Automation is the delegation of human control functions to technical equipment. Automation of any system can be achieved by making the system smart. The purpose of this project is to provide a generic solution for implementing an IR receiver in software using MSP430 microcontroller. The main problem in home automation is user cannot operate different devices using single switch. This problem can be reduced by using a single rc5remote. Therefore any physically disabled people can operate their home appliances on their own making them independent. Thus it provides a user friendly environment to user.. In our project we use rc5remote to operate only six electrical equipment. primarily concentrate on showing how RC5 protocol can be used for home automation system. This design of RC5 protocol based remote control using MSP430 Microcontroller is based on IR signals, that IR signals is transmitted by remote that signal is received by the IR sensor and those signals is controlled by the MSP430 Microcontroller and gives immediate result by switching ON/OFF the corresponding electrical devices. The devices can also be switched ON/OFF by the capacitive touch sensor or touch pad which is mounted on the booster pack. The advantages of automation are 1. Reduce the manpower, 2. Increases efficiency and accuracy

2. OBJECTIVE

The main objective of this project is to provide a generic solution for implementing an IR receiver in software using MSP430 microcontroller. The problem associated with the home appliances is that we cannot switch ON/OFF all the electronic devices using single device.

This problem can be overcome by using a single remote control which works on RC5 protocol. Therefore any bed-ridden or physically disabled people can operate their home appliances on their own making them independent. This design of RC5 protocol based remote control using

MSP430G2553 Microcontroller is operated using IR signals, controlled by the MSP430G2553 Microcontroller and gives immediate result by switching ON/OFF the corresponding electronic devices.

3. OPERATING PRINCIPLE

In this proposed project the electronic devices is controlled by two methods one is mainly by RC5 remote and the other method is by capacitive touch sensor which is present on the booster pack. In The first method Fig -1 shows RC5 protocol will be transmitted by the remote control through IR radiation. These IR radiations will be sensed by the IR receiver TSOP28238 and it will be converted into electrical signal. This signal will be received by the MSP430G2553 Microcontroller which is mainly responsible for switching ON/OFF the corresponding devices.

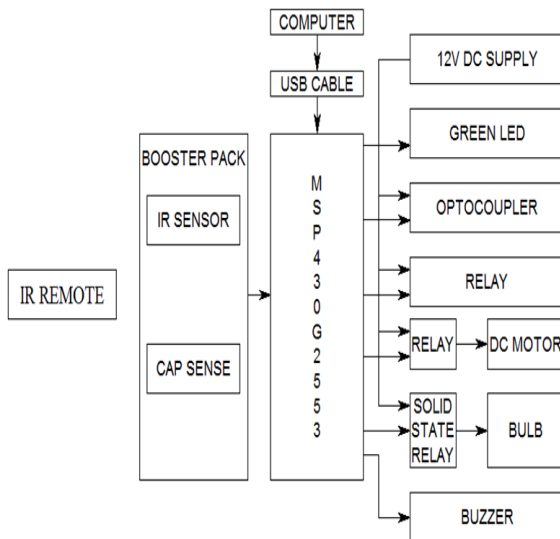

Fig -1: Detailed Block Diagram of controlling electronic devices using remote and capacitive touch sensor

The devices can also be switched ON/OFF by the touch pad which is mounted on the booster pack. Fig- 1 shows the detailed block diagram of controlling electronic devices using remote. This technology is mainly based on the Cap sensing.

The microcontroller does the decoding of the signal. For the microcontroller to perform operation it has to be programmed. This can be achieved by programming the microcontroller by using a development tool called "IAR Workbench".

Infrared remote control must transmit user commands through button-presses and output the appropriate IR

signal through the air to an IR receiver. To allow the receiver to distinguish between the remote's IR signal and all the other sources of infrared light, IR remote controls modulate their signals, usually between 30–60 kHz. In this application report, 40 kHz is used. A mark is defined as the presence of a 40 kHz modulated IR signal and a space is the lack of an IR signal. The specific IR protocol defines the how the series of marks and spaces translate to a user command.

The PCA8521 is used in infrared remote control transmitters. It generates output pulses, in accordance with the RC5 protocol, when a key is pressed. The IC does not contain a software programmable processor. However, it does contain a ROM in which the codes that have to be transmitted are stored.

4. COMPONENTS REQUIRED

The hardware components required for controlling of different electronic devices by using RC% remote is as follows

4.1. MSP430G2553 Microcontroller

MSP430G2553 microcontroller is one of the most advanced microcontroller. MSP430G2x53 series are ultra-low-power mixed signal microcontrollers with built-in 16-bit timers, up to 24 I/O capacitive-touch enabled pins, a versatile analog comparator, and built-in communication capability using the universal serial communication interface. the architecture combined with five low power modes, it is a 16bit RISC CPU and it contains a 16bit register. Fig-2 shows the MSP430G2553 microcontroller.



Fig -2: MSP430G2553 Microcontroller

4.2. LED

A light-emitting diode (LED) is a two-lead semiconductor light source. It is a pn-junction diode, which emits light when activated. When a suitable voltage is applied to the leads, electrons are able to recombine with electron holes within the device, releasing energy in the form of photons. This effect is called electroluminescence, and the color of

the light is determined by the energy band gap of the semiconductor.

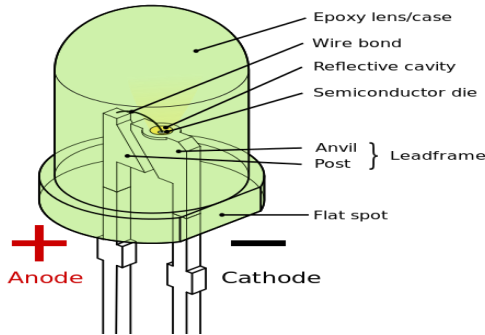

Fig -3: LED

4.3. Optocoupler

Optocoupler are designed to provide complete electrical isolation between an input and output circuits. . The useful purpose of isolation is to provide protection from high voltage, surge voltage and low level noises that could be produces errors in the output. Optocouplers also provides interface between different voltage levels.

The input current of an optocoupler can be photo transistor, LDR, Photo diode and LASCR. When the input voltage of LED is forward biased, the LED emits light, this transmitted light turns ON the photo sensitive device which produce nearly the same voltage at output. Fig-4 shows the optocoupler it works with 12v power supply.



Fig -4: Optocoupler PC817

4.4. Relay

The MAX232 is an integrated circuit that converts signals from an RS-232 serial port to signals suitable for use in TTL compatible digital logic circuits. The MAX232 is a dual driver/receiver and typically converts the RX, TX, CTS and RTS signals. The MAX 232 is to connect a serial port device

to a serial port which uses the RS232 standard. Fig -5 shows the relay.



Fig -5: Relay

4.5. Buzzer

A buzzer or beeper is an audio signaling device, which may be mechanical, electromechanical, or piezoelectric. Typical uses of buzzers and beepers include alarm devices, timers and confirmation of user input such as a mouse click or keystroke. The piezo buzzer produces sound based on reverse the piezoelectric effect. Fig-6 shows the buzzer.



Fig -6: Piezo Buzzer

4.6. 12V DC Power supply

A power supply is an electronic device that supplies electric energy to an electrical load. The primary function of a power supply is to convert one form of electrical energy to another and, as a result, power supplies are sometimes referred to as electric power converters. The PS5R-SB12 belongs to IDEC's Slim Line PS5R series of compact switched mode DIN rail power supplies. Fig -7 shows the DC power supply.



Fig -7: DC Power supply

4.7. Motor

DC motor is a simple device which converts electrical energy into mechanical energy. DC motors are widely used because of their small size and high energy output. They are excellent for powering drive wheels and other mechanical assemblies. It operates with 12V. Fig-8 shows the dc motor.



Fig -8: DC Motor



Fig -10: Snapshot of First output (green LED)

The Fig-10 shows the Snapshot of the first output i.e Green LED. Here the LED is turned ON when the first button is pressed in the remote and along with that it also indicates the output when the first cap touch is sensed on the booster pack. The device can be turned OFF by pressing the same button or cap touch again.

Only single device will be turned ON/OFF at a time. Fig -11 shows the Snapshot of all the electronic devices. Here all devices are turned ON by using IR remote. All the devices can be turned OFF by pressing the same button or cap touch again.

5. FLOW CHART

The Flow Chart of the program in the MSP430G2553 Microcontroller section is carried out as shown in Fig -9

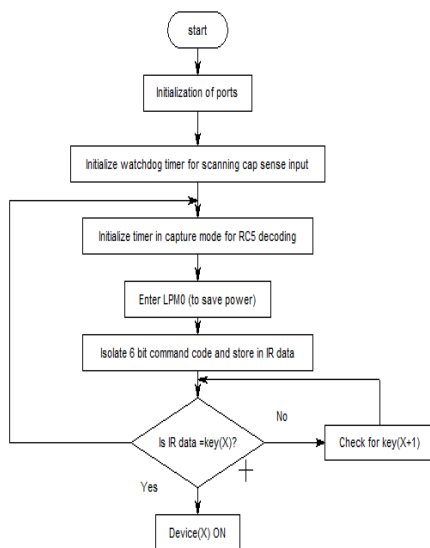

Fig -9: Flowchart of Transmitter section

6. RESULTS

The proposed project comprises of the electronic devices will be controlled by using IR remote. The IR signal will be transmitted from the remote which will be sensed by the IR sensor which will turn ON/OFF the corresponding electronic devices.

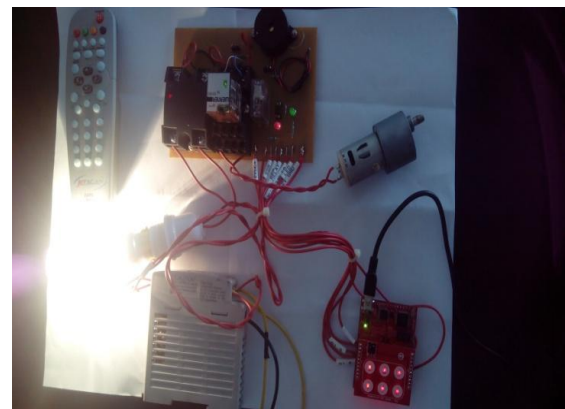

Fig -11: Snapshot of all devices

7. FUTURE WORK

The system we have designed in the project is only for controlling of six devices, further can be implemented by using a different protocol to control more than six electronic devices. This method can be used in industries.

8. CONCLUSIONS

The proposed remote control and its interfaces are low cost and much easier to use than other input device. In this project we have demonstrated how we can design a remote control to control the electronic devices. The basic idea was to understand how RC5 protocol can be used as an input for controlling different electronic devices. One more advantage of this proposed project is done by controlling by means of touch pad, just a touch on particular key on the booster pack will control the device. Thus the proposed project can be either controlled by remote or touch pad.

REFERENCES

- [1] M.H Sherif "Intelligent homes: A new Challenge in telecommunications standardization", Communications Magazine, IEEE, vol. 40, no. 1, pp.8 2002 ",
- [2] Brewster, S.A., Chohan, F., and Brown, L., "Tactile Feedback for Mobile Interactions," ACM CHI2007 Proceedings, pp.159-162, 2007
- [3] **Keuling, Christopher** "Touchscreen Press Deep Into Consumer Electronics". **ECN Magazine**
- [4] Vaughan Nichols, S.J., "New Interfaces at the Touch of a Fingertip," IEEE Computer, Vol.40, No.8, pp.12-15, August 2007.
- [5] M Weiser "The Computer for the 21st ce ntury", Scientific American, pp.94 -104 1991

BIOGRAPHIES



Sowjanya M N, working as a assistant professor in dept of IT of GSSSIETW, Mysuru



Bettisha Baby Thomas , pursuing her under graduation degree in IT at GSSSIETW, mysuru



Kavana.J, pursuing her under graduation degree in IT at GSSSIETW, mysuru



Pooja B S , pursuing her under graduation degree in IT at GSSSIETW, mysuru



Prathima R, pursuing her under graduation degree in IT at GSSSIETW, mysuru