

Modeling & Simulation of Emergency Power Supply System and Emergency Transfer Scheme for PFBR Operator Training Simulator

B. SubbaRaju, K. VijayaKumar, H.Seetha, T. Jayanthi, S.A.V.SatyaMurthy

¹ Technical Officer (D), Computer Division, IGCAR, Tamilnadu, India

² Scientific Officer (E), Computer Division, IGCAR, Tamilnadu, India

³ Scientific Officer (E), Computer Division, IGCAR, Tamilnadu, India

⁴ Scientific Officer (H), Computer Division, IGCAR, Tamilnadu, India

⁴ Outstanding Scientist, Director EIRSG, IGCAR, Tamilnadu, India

Abstract - Nuclear Power plant operational experience and safety analysis indicates that the human error is the main cause for severe accidents in plants. To improve the human reliability, simulator based training has been made mandatory in nuclear power plant operator training program. A Full Scope Replica Operator Training Simulator is made operational for Prototype Fast Breeder Reactor (PFBR) before commissioning of the real plant. This gives hands-on experience to PFBR operators for steady state and various transient conditions of the plant. It helps the operators for smooth transition from the simulator control room to main control room. The simulated systems of PFBR are Neutronics System, Primary & Secondary Sodium System, Core Temperature Monitoring System, Steam Water System and Electrical System. This paper discusses about Modeling and simulation of Emergency Power Supply System, the associated logics, controls which is a part of Electrical System. Simulation of Emergency Transfer Scheme (EMTR) adopted for PFBR, automatic starting of Diesel Generators and restoring the safety loads sequentially according to priority are also included in the paper. It also details about classification of power supply system in nuclear power plant and importance of Class III Emergency Power Supply System.

Key Words: Operator Training Simulator; Prototype Fast Breeder Reactor; Modeling and simulation; Electrical System; Emergency Power Supply System; Emergency Transfer Scheme;

1. INTRODUCTION

In Nuclear Power Plant, safety is ensured by well trained operators possessing the plant related process knowledge. A high fidelity Full Scope Simulator has become significant

in the training program to transfer the plant related knowledge to the operators for safe and efficient operation of the plant. A Full scope replica simulator for PFBR is being developed at Indira Gandhi Centre for Atomic Research (IGCAR), Kalpakkam which simulates all the reactor subsystems. Electrical system is one of the major sub-systems of PFBR which comprises normal and emergency power supply systems. Normal power supply is Generator power supply during plant operation and power supply from the grid during Start up of the plant or incase of Generator trip event. Emergency power supply is the onsite power supply to the safety related systems which supports the loads related to plant safe shutdown and to remove the decay heat. The emergency power supply system includes Class III power supply back up provided by Diesel Generators (DG), Class II No break AC power supply and Class I No break DC power supply. In case of normal power supply failure, UPS supplies power to Class II system loads and Rectifier/Charger feeds the loads pertaining to Class I system until DG power supply is restored. The moment DG incomer closes, these loads are fed by diesel power supply and the remaining class III safety loads are restored according to the priority. Here modeling and simulation of Class III Emergency power supply system is included.

2. PFBR OPERATOR TRAINING SIMULATOR

PFBR is a 500 MWe, sodium cooled, pool type reactor based on Mixed Oxide (MOX) fuel, which is first of its kind in the country being built with total indigenous technology at Kalpakkam. It is a mandatory requirement by Atomic Energy Regulatory Board (AERB) to implement a Full Scope Simulator in advance to train and qualify the plant personnel before commissioning of the reactor. For PFBR, it is recommended to develop a Full Scope Replica Operator Training Simulator which is being built in house at Computer Division in association with Reactor Engineering Group and Nuclear Safety & Engineering Group of IGCAR, Kalpakkam.

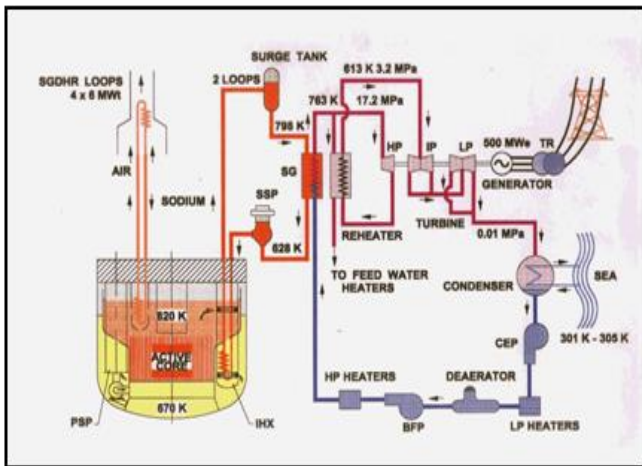

Fig -1: PFBR Flow sheet

Full Scope Simulator simulates the entire plant operations starting from nuclear core to Turbo generator and to bring in Replica feature, simulator control room is built with 1:1 correspondence with main control room with respect to its panels, desks, chairs, lighting arrangement etc [1,2]. Fig. 1 shows the Flow sheet of PFBR.

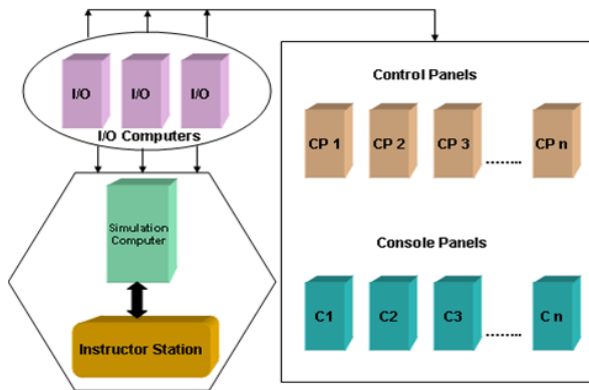

Fig -2: Hardware Architecture of PFBR Simulator

Fig. 2 shows the hardware architecture of PFBR Operator Training Simulator which consists of plant consoles and control panels, Simulation Computer, Input /Output systems, Instructor Station, Simulation Network and Power Supply unit. Simulation Computer executes various mathematical models of the sub-systems in real time. It takes inputs from control panels and consoles through I/O systems, processes them and responds by giving the information to I/O system for display on indicators, recorders and initiate alarms in real time [3].

3. CLASS III EMERGENCY POWER SUPPLY SYSTEM OF PFBR

The Class III power supply system is provided with two independent divisions. Each division is divided into two

sections which consist of 6.6 kV bus each. The Class III 6.6 kV buses are normally supplied from the class IV busses. On loss of Class IV supply each section is provided with standby emergency Diesel Generators as on-site sources of AC power to feed the Class III supply system. Each DG is rated to supply 50% of the total emergency power supply demand with a rating of 4.5 MVA which can feed the entire division safety loads on loss of one DG.

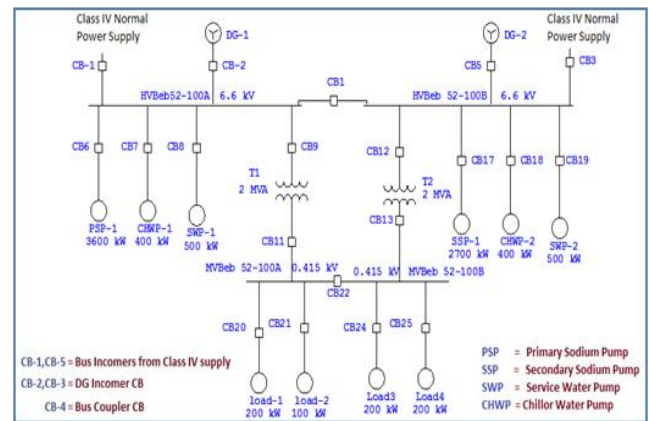

Fig -3: Class III Power Supply Division

The Class III, 415 V busses or the Power Control Centers (PCC) are fed from the 6.6 kV Class III busses through the Low Tension (LT) auxiliary transformers. Six PCC's are present for Class III power supply. The major loads in Class III system are Variable Speed Drives for Primary sodium & secondary sodium, Chiller water pumps and service water Pumps [4]. Fig. 3 shows Single Line Diagram of Class III power supply system Division-1.

4. MODELLING & SIMULATION

Modeling includes Class III 6.6 kV Emergency power supply and 415 V PCC sections and related loads modeling like Primary sodium drive system etc.

4.1 Process Modeling

Process Model is the component represented by mathematical equations which calculates dynamic parameters during runtime simulation. Process modeling comprises component modeling like Diesel Generator, Automatic Voltage Regulator and Circuit Breaker etc by configuring the rated parameters. Further connecting these configured components as per the design single line diagram to represent the actual system. Stand alone testing has been done by comparing the output parameters of the each model with the design parameters. Fig. 4 shows the Single Line Diagram (SLD) and process modeling of Motor drive system.

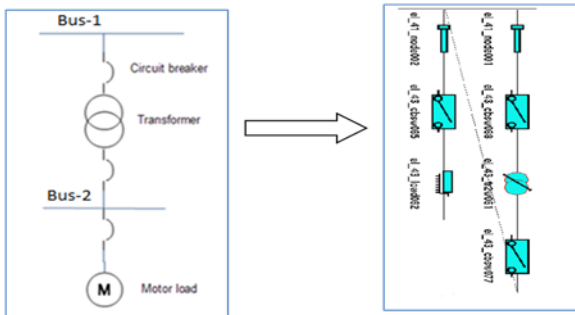

Fig 4: Motor Drive system SLD and process model

4.2 Logic Modeling

Logic Model is a control schematic which is represented by the digital building blocks to control the process components. Logic Modeling of Class III power supply system includes modeling of control schematics of circuit breakers(CB) and Modeling of Emergency Transfer scheme (EMTR).

4.2.1 Control schematics of Circuit Breakers:

Control schematic of circuit Breakers which consists of relays and timers is converted in to a logic diagram by the combination of basic gates and functional blocks. Logic diagram of circuit breaker checks the input parameters like REMOTE/LOCAL, Distributed Digital Control System (DDCS) / Hardware Panel (HWPNL) and CLOSE/TRIP from EMTR logic etc. it also checks CB Lockout relay conditions like over current, Earth fault relay etc. After checking all these conditions it will give permission to energize the Close/Trip coil of circuit breaker according to the input.

4.2.2 Emergency Transfer Scheme :

EMTR logic is designed to start Diesel Generators and feed the plant safety related loads according to priority incase normal power supply fails. On loss of power supply to the Emergency bus, logic is developed to give start command to the DG, trip signal to all the circuit breakers like bus incomer CB, Bus coupler CB and feeder CB to the loads by checking the DG Voltage and Frequency. Further confirmation of tripping of all CB, logic gives close signal to DG incomer CB and gives permission to emergency loads pick up. The moment DG CB closes DG power supply feeds the Class II and Class I system loads. Logic gives the close signal to plant Safety related load feeder CB according to priority with some time intervals like 5s,10s,20s etc. The EMTR logic also checks second DG failure, gives close signal to bus coupler and load picked up permission to another section with some time interval [5].

4.2.3 Virtual Panel Model

Virtual Panel is the emulation of hardware panel which is used to display run time process parameters for verification and validation of all the process models

running in integrated mode. It is also used to control the process components like ON/OFF of CB, DG voltage RAISE/LOWER etc.

4.2.4 Integration

Integration of Process, logic and virtual panel model includes allocating unique variable to each signal in common database in order to establish a proper communication among all these modules.

5. TESTING OF STEADY STATE OPERATION

Testing of steady state operation ensures the dynamic behavior of process models and it helps in checking the consistency of process parameters. In normal operation Class III power supply system gets power supply from Class IV 6.6 kV busses. The incoming feeders are kept in closed condition to get the power supply from Class IV system. Fig. 5 shows the steady state parameters of Class III power supply system Division-2. First Division is replica of Second Division.

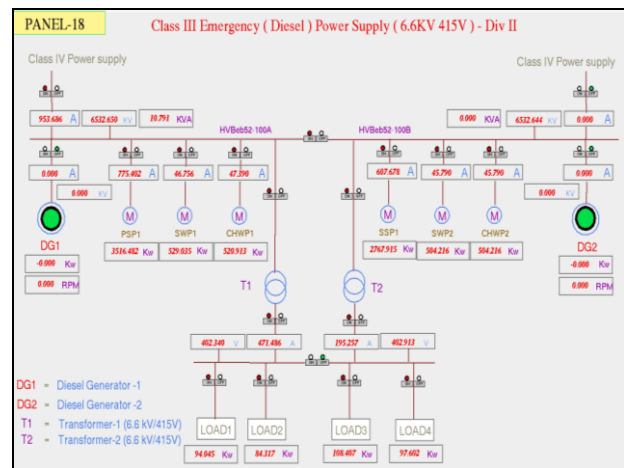

Fig 5: Soft Panel shows normal operation of Class III Power supply Division-2

6. TESTING OF TRANSIENTS

Testing of transients ensures the behavior of process models and control logics in abnormal condition. Failure of class IV power supply with emergency backup supply to station emergency loads is tested as follows.

6.1 Class IV power supply failure

Class IV power failure scenario is applied from instructor station which reflects loss of normal power supply to Class III emergency power supply system.

6.1.1 Two Diesel Generators feeding the station emergency loads in one division

On the loss of power supply to Emergency buses of each section, start command to Diesel Generator is given by the EMTR logics of each section. Two Diesel Generators are started by checking REMOTE/AUTO/EMTR permission from control panel and picked up the voltage and speed within a specific time interval. EMTR logic has given the close command to the DG incomer CB and Auto load picked up permission of each section in the division after checking the DG voltage and frequency. The moment DG Incomer CB closes the loads corresponding to Class II and Class I system is fed by diesel supply and Battery banks are charged through Rectifier charger. The plant safety loads are restored according to the priority with time intervals by giving close signal to the motor feeders and MCC bus feeders by the EMTR logic. The parameters like DG voltage, power and speed are captured and plotted in real time simulation as shown in fig 6, 7 & 8 respectively.

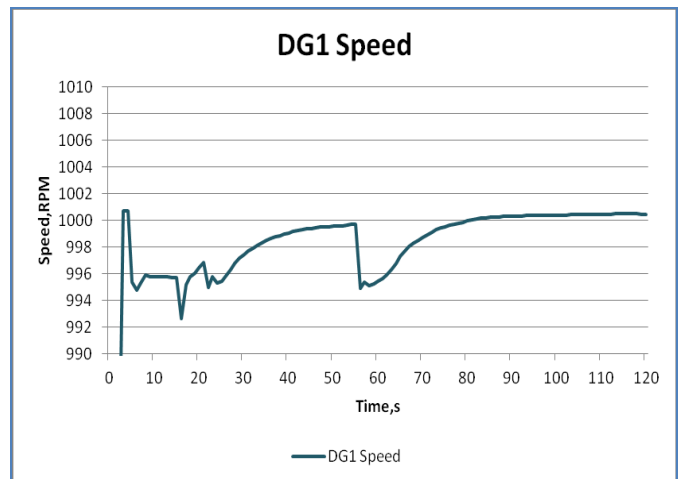

Fig 8: DG-1 Speed

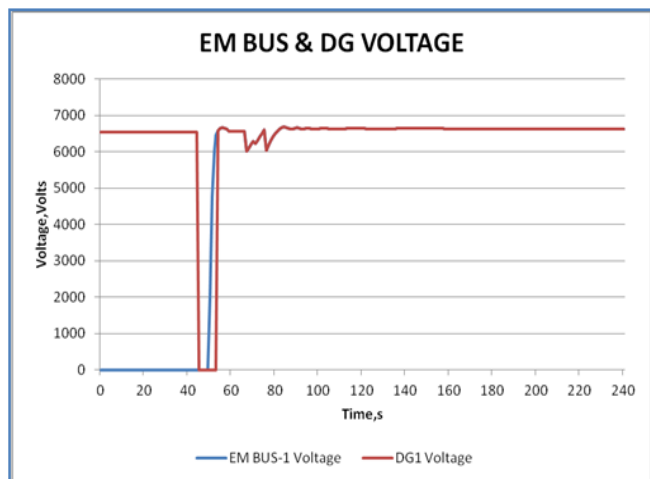

Fig 6: EM BUS-1 & DG Voltages

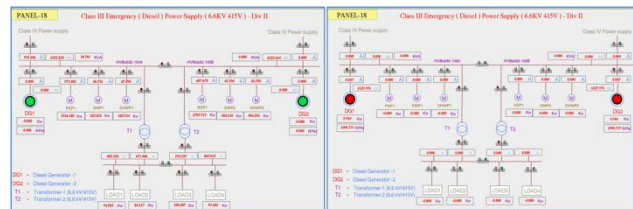

Fig a: After Class IV failure

Fig b: the moment DG incomer closes

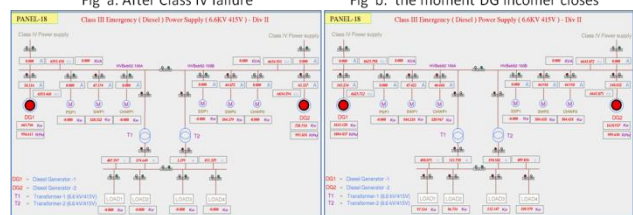

Fig c: 15 Sec loads picked up

Fig d: 45 sec loads picked up

Fig 9: Class III Power Supply System Division 2

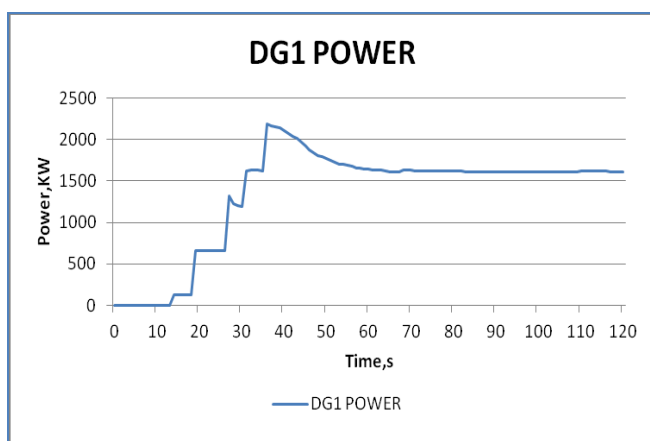

Fig 7: DG-1 power

Fig. 9 shows the soft panel of Class III power supply system division 2. It shows the emergency operation with Two Diesel Generators feeding each section emergency loads in division-2.

6.1.2 One DG feeding the station emergency loads in one division on failure of second DG

The EMTR logics have given start command by checking the power supply to the Emergency buses of each section. One Diesel Generator has started and picked voltage and speed and other diesel generator failed to start due to internal fault. The Running DG has picked the station emergency loads of the corresponding section according to priority with time intervals through EMTR logic. Simultaneously, the EMTR of failed DG permitted to close the division bus coupler CB and issued the load picked permission to the corresponding section after checking the running DG voltage and frequency. Fig. 10,11,12 shows the profiles of important process parameters.

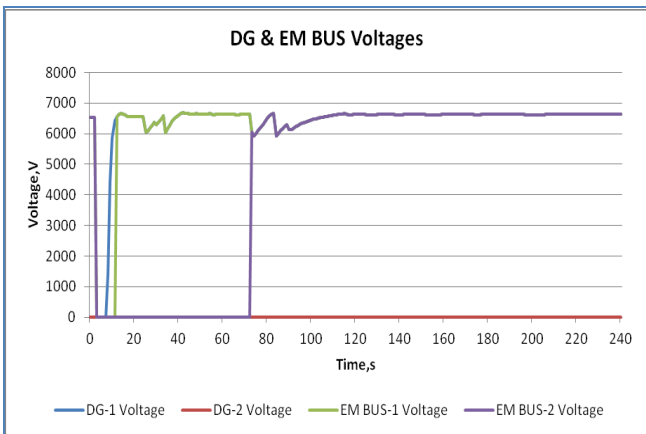

Fig 10: EM BUS-1 & DG Voltages

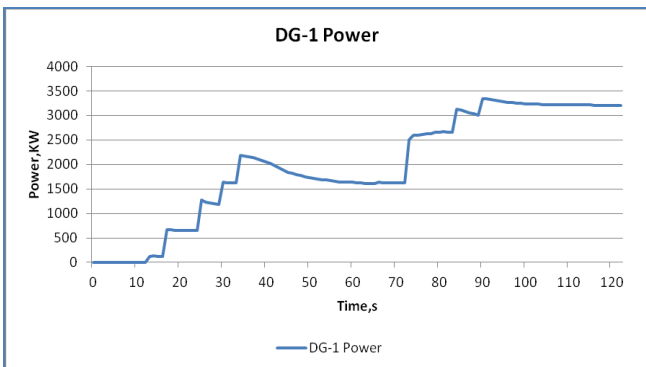

Fig 11: DG-1 power

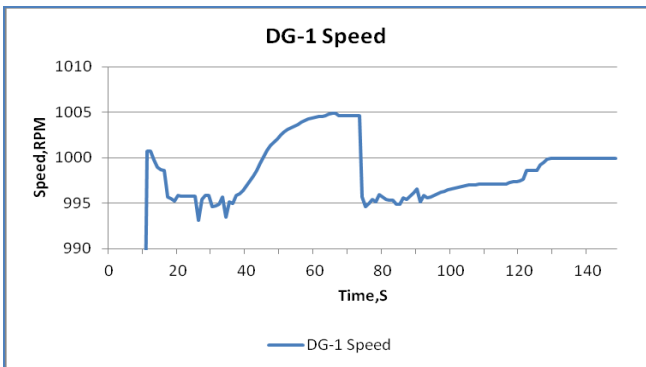

Fig 12: DG-1 Speed

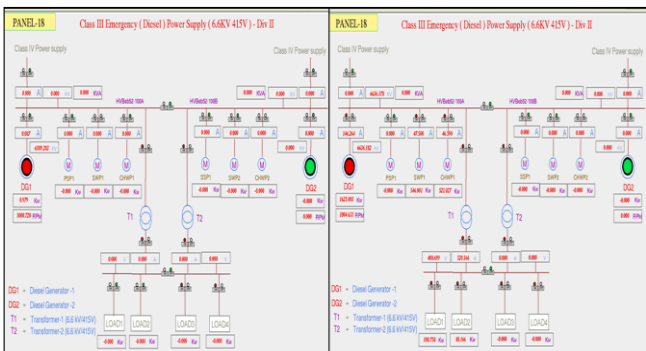

Fig 13: Soft panel of Division-2 showing DG-1 picked up the own section loads (5Sec, 45, Sec)

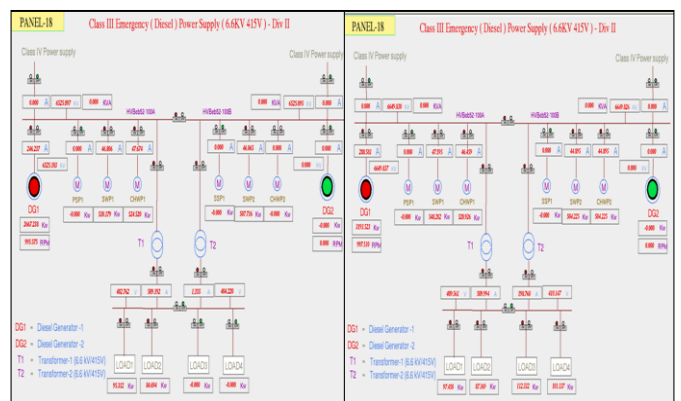

Fig 14: Soft panel of Division-2 showing DG-1 picked up the other section loads (5Sec , 45,Sec)

Fig. 13, 14 shows the emergency operation with one DG feeding entire division emergency loads.

7. VERIFICATION AND VALIDATION

The developed process models and associated control logics are simulated and demonstrated to the committee of design experts. The behavior of the logic models are analyzed and compared with the design reports/schematics for steady state and various transient conditions in the plant. The simulated model performance is found to be satisfactory.

8. CONCLUSION

Class III Emergency power supply system and associated control schematics of Circuit breakers are modeled and simulated. EMTR logic is also modeled and tested in the simulation environment during normal operation and emergency conditions and the results are satisfactorily. Diesel Generator performance was observed during load picked up on emergency conditions.

The simulation is used to get the Operating personnel familiar with the Class III emergency power supply system and the performance of the Diesel Generators and EMTR logic. It also helps to train the operator to restore the emergency power supply for safe shutdown of the plant on loss of Class IV power supply without becoming panic.

ACKNOWLEDGMENT

The authors gratefully acknowledge the support and guidance provided by Shri N. Theivarajan, Head PPCD, Smt N.M. Vijaya, SO/F, T. Chandra Kiran SO/D from EPS/PPCD and all other colleagues from Reactor Engineering Group. The authors are greatly indebted to the constant guidance & motivation provided by Dr P, R. Vasudeva Rao IGCAR.

REFERENCES

- [1] Operator Training Simulator, T.R. Ellappan, S. Athinarayanan, PFBR/08610/DN/1000/Rev A, 2003
- [2] Scope Document for PFBR Operator Training Simulator, T. Jayanthi, S.A.V. SatyaMurty, K.K. Kuriakose, S. Srinivasan, M.L. Jayalal, PFBR/08610/DN/1003/REV-A, IGCAR, 2007.
- [3] Hardware Architecture of PFBR Simulator, S.A.V. SatyaMurty, P. Shanmugam, Uma Seshadri, PFBR/08610/DN/1001/Rev A, (2005)
- [4] PFBR Preliminary Safety Analysis Report, Indira Gandhi Centre for Atomic Research, Department of Atomic Energy, Chapter-9 "Electrical Power systems", Rev0,(2004)
- [5] Control Schematic Diagram Emergency Power supply System Control Panel-3, PFBR/52300/CS/1104/REV-3,IGCAR-2007
- [6] Control Schematic Diagram Emergency Power supply System Control Panel-4, PFBR/52300/CS/1105/REV-3,IGCAR-2007

Journal Publications / Conference Papers.



T.Jayanthi received her B.E (Hons) Degree Madras University, T.N in 1983. She joined in Indira Gandhi Centre for Atomic Research (IGCAR) in 1984, worked as a commissioning Engineer in FBTR and various other project in IGCAR. Presently function as Head of Simulator Section and working on Development and implementation of PFBR full scope operator training simulator and related research and development activities. She has more than 45 Journal Publications / Conference Papers / proceedings.

BIOGRAPHIES



B.Subba Raju received her B.Tech Degree from Nagarjuna University AP in 2009. He joined in Indira Gandhi Centre for Atomic Research (IGCAR) in 2010. He is currently a Technical Officer-D in Electronics, Instrumentation and Radiological Safety Group-IGCAR. He has 3 Journal Publications / 3 Conference Papers.



Dr S.A.V Satya Murty received his BTech Degree from Jawaharlal Nehru Technological University, A.P in 1977. Later, he joined one year orientation course in Nuclear Science & Engineering (21st Batch) at Bhaba Atomic Research Centre (BARC)-Mumbai and then he joined in Indira Gandhi Centre for Atomic Research (IGCAR) in 1978. He is currently an Outstanding Scientist, Director of Electronics, Instrumentation and Radiological Safety Group-IGCAR. He has 110 Journal Publications / Conference Papers, 40 Internal Design Reports and edited two International Conference Proceedings.



K.Vijayakumar received her B.E Degree from Anna University, T.N in 1994. He joined in Indira Gandhi Centre for Atomic Research (IGCAR) in 2001. He is currently a Scientific Officer-E in Electronics, Instrumentation and Radiological Safety Group-IGCAR. He has 5 Journal Publications / Conference Papers.



H.Seetha received her B.E Degree from Bharathidasan University, T.N in 1997. She joined in Indira Gandhi Centre for Atomic Research (IGCAR) in 2001. She is currently a Scientific Officer-E in Electronics, Instrumentation and Radiological Safety Group-IGCAR. She has 14