

# AUTOMATION OF SHOPPING CART TO EASE QUEUE IN MALLS BY USING RFID

Mr. yathisha L, Abhishek A<sup>2</sup>, Harshith R<sup>3</sup>, Darshan Koundinya S R<sup>4</sup> & Srinidhi K M<sup>5</sup>

<sup>1</sup> Asst. Professor, Dept. of ECE, ATME college of Engineering, Mysore.

<sup>2 3 4 5</sup> Final year students, Dept. of ECE, ATME college of Engineering, Mysore.

Abstract – Specially, it becomes more crowded on holidays. People purchase different items in the malls and puts them in the trolley. At the cash counter billing process is done using bar code scanner. This is very time consuming process. To avoid this we are developing a system which we **called as 'AUTOMATION OF SHOPPING CART Using RFID module and ZIGBEE module'**. In this system we are using RFID tags instead of barcodes. This RFID tags will be on the product. Whenever the customer puts a product into trolley it will get scanned by RFID reader and product price and cost will be display on LCD display. Like this the process goes on. We are using ZIGBEE transmitter which will be at trolley which is used to transfer data to main computer. At the main computer ZIGBEE receiver will be placed which will receive data from transmitter.

## 1. INTRODUCTION

The barcode system is no longer the best way to business operation. Customers are tired of waiting in long, slowly moving checkout line in departmental stores, especially, in holidays. With the decrease of prices through efficiencies of technology and large-scale production of semiconductor wireless components, there has been a search for new markets in which semiconductor chips can be used. This has led to the use of RFID also known as smart tags. RFID stands for Radio Frequency Identification. In a very interesting article, the San Jose Mercury News tells us about Charles Walton, the man

behind the radio frequency identification technology (RFID). In this paper we are using RFID technology for making an futuristic billing trolley. A device "BILLING TROLLEY" also called as "Data Logger Device" is an information storage system. Here the system parameters of an Futuristic Trolley like products name, products amount, company name etc. are continuously recorded. The system displays as well as announces the name of the product and cost. This is also applicable for various applications and using proper interface the recorded data can be downloaded on and stored into a computer. The trolley being wireless consist of ZIGBEE module hence free to move in large area. The system is an efficient means for a commercial purpose as it is less time consuming and easy to control.



## 2. LITERATURE SURVEY

Shopping in the present day usually involves waiting in line to get your items scanned for checkout. This can result in a great deal of wasted time for customers. Furthermore, the technology currently used in checkouts barcodes - is from another era, developed in the 1970s. Today barcodes are found on almost every item. Barcodes are a universal technology in that they are the norm for retail products; stores that own a barcode reader can process barcodes and imprint it on the products. The most important factor that is involved in barcode scanning is that the product should be in the Line of Sight (LOS) of the reader in order to get the barcode imprinted on the product scanned.

Nowadays, if a consumer would like to buy something at a shopping mall, consumers need to take the particular items from the display shelf and then queue up and wait for their turn to make payment. Problem will surely arise when the size of a shopping mall is relatively **huge and sometimes consumers don't even know where certain items are placed.** Besides, consumers also need to queue for a long time at the cashier to wait for turn to make payment. The time taken for consumers to wait for the customers in front of the queue to scan every single item and then followed by making payment will definitely take plenty of time.

This condition will surely become worst during the season of big sales or if the shopping mall still uses the conventional way to key in the price of every item by hand to the cash register. On the other hand, consumers often have to worry about plenty of things when going to the shopping mall.[1]

For example, most consumers will worry the amount of money brought is not enough to pay for all the things that wanted to be bought until

it comes to our turn to pay at the cashier, consumers might also worry that whether certain food product available at the shopping mall are suitable for vegetarian since most of the food product might not be stated clearly. It will be a great convenience if the information of items that are available in the shopping mall can be obtained. It will be a great improvement on the existing system if the technology of RFID is implemented. Consumers will be able to get information of all the items at shopping mall, total up the prices of items as they shop, and save unnecessary time at the cashier.[2]

## 3. EXISTING METHOD

Currently available method in shopping malls is barcode method. In this method there are barcode labels on each product which can be read through specially designed barcode readers. A barcode reader (or barcode scanner) is an electronic device for reading printed barcodes. Like a flatbed scanner, it consists of a light source, a lens and a light sensor translating optical impulses into electrical ones. Additionally, nearly all barcode readers contain decoder circuitry analyzing the barcode's image data provided by the sensor and sending the barcode's content to the scanner's output port.[3]

## 4. PROPOSED METHOD

If compared, RFID technology is found to be more comprehensive than barcode technology. It is possible to read RFID tags from a greater distance. An RFID reader can access the information of the tag from a distance of around 300 feet, whereas barcode technology can't be read from a distance of more than 15 feet. RFID technology also scores over barcode technology in terms of speed. RFID tags can be

interpreted much faster than barcode tags. Barcode reading is comparatively slower because it requires a direct line of sight. On an average, a barcode reader takes around one second to successfully interpret two tags, whereas in the same time the RFID reader can interpret around 40 tags. RFID tags are well protected or either implanted inside the product, and hence is not subjected too much wear and tear. Interpreting a barcode requires a direct line of sight to the printed barcode, because of which the barcode is printed on the outer side of the product, and is thus subjected to greater wear and tear. It also limits the re-utilization of barcodes. As barcode lacks read and write facility, it is not possible to add to the information already existing on it. On the other hand rewriting on RFID tags is possible

5. PROPOSED SYSTEM BLOCK

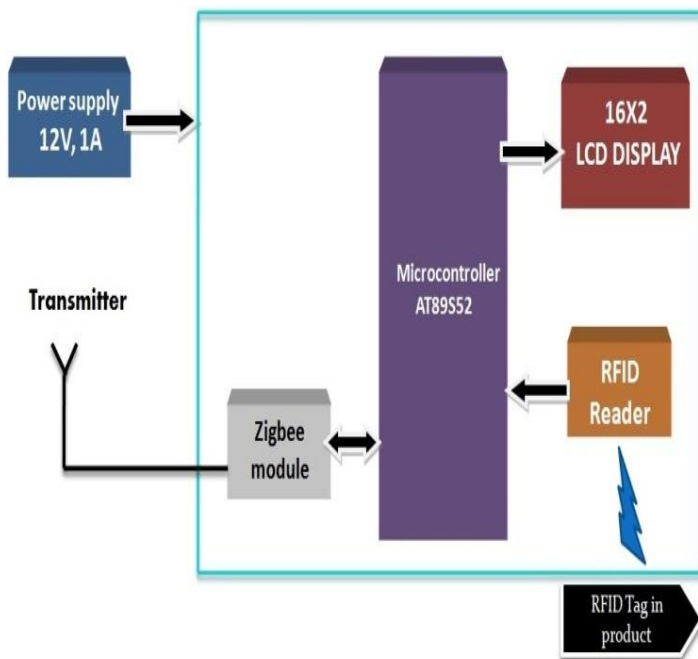

Figure 5.1: Block diagram of transmitter

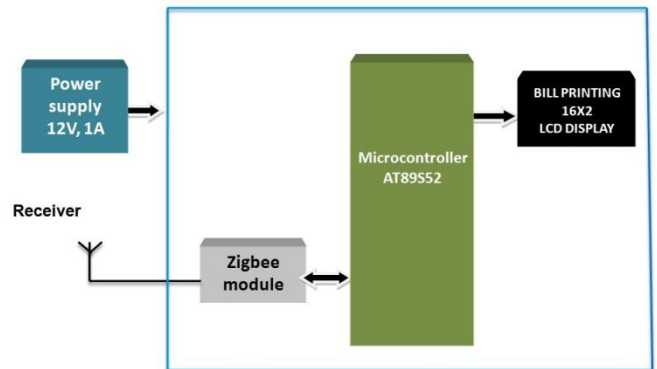

Figure 5.2: Block diagram of receiver

6. SYSTEM FLOW<sup>[3]</sup>

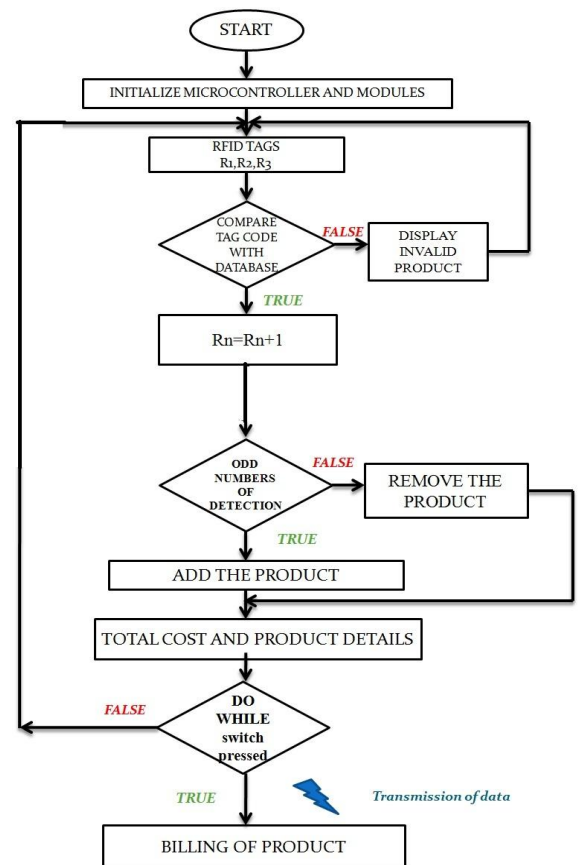

Figure 6.1: System Flow Diagram

## 7. SYSTEM ARCHITECTURE

- Microcontroller AT89S52
- Zigbee Transmitter and receiver
- RFID reader
- Power supply
- LCD display

### 7.1 Microcontroller AT89S52

The AT89S52 is a low-power, high-performance CMOS 8-bit microcontroller with 8K bytes of in-system programmable Flash memory. The device is manufactured using Atmel's high-density nonvolatile memory technology and is compatible with the industry-standard 80C51 instruction set and pinout. By combining a versatile 8-bit CPU with in-system programmable Flash on a monolithic chip, the Atmel AT89S52 is a powerful microcontroller which provides a highly-flexible and cost-effective solution to many embedded control applications. The AT89S52 provides the following standard features: 8K bytes of Flash, 256 bytes of RAM, 32 I/O lines, Watchdog timer, two data pointers, three 16-bit timer/counters, a six-vector two-level interrupt architecture, a full duplex serial port, on-chip oscillator, and clock circuitry.

#### 7.1.1 Features of AT89S52

- Compatible with MCS<sup>®</sup>-51 Products
- 8K Bytes of In-System Programmable (ISP) Flash Memory – Endurance: 10,000 Write/Erase Cycles
- 4.0V to 5.5V Operating Range
- Fully Static Operation: 0 Hz to 33 MHz

- Three-level Program Memory Lock
- 256 x 8-bit Internal RAM
- 32 Programmable I/O Lines
- Three 16-bit Timer/Counters
- Eight Interrupt Sources
- Full Duplex UART Serial Channel
- Low-power Idle and Power-down Modes
- Interrupt Recovery from Power-down Mode
- Watchdog Timer
- Dual Data Pointer
- Power-off Flag
- Fast Programming Time
- Flexible ISP Programming (Byte and Page Mode)
- Green (Pb/Halide-free) Packaging Option

#### 7.1.2 Pin Configuration

##### 40-lead PDIP

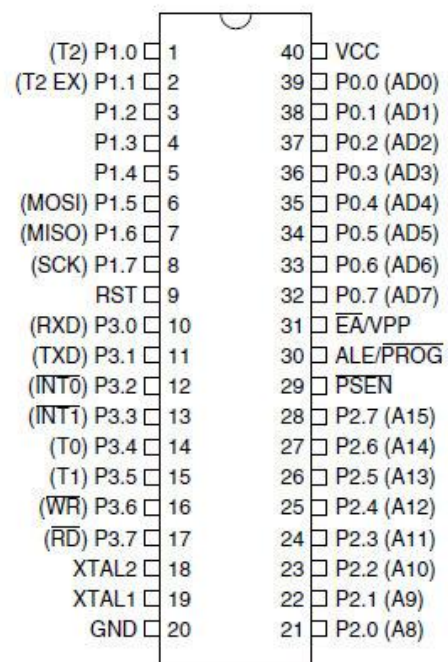

## 7.2 RFID READER

RFID readers or receivers are composed of a radio frequency module, a control unit and an antenna to interrogate electronic tags via radio frequency (RF) communication (Sarma et al. 2002). The reader as shown in fig 7.2 powers an antenna to generate an RF field. When a tag passes through the field, the information stored on the chip in the tag is interpreted by the reader and sent to the server, which, in turn, communicates with the integrated library system when the RFID system is interfaced with it (Boss 2004). Radio frequency identification (RFID) in a variety of ways including automatic identification and data capture (AIDC) solutions. We pride ourselves in providing customers with inexpensive RFID solutions that integrate well with other systems.

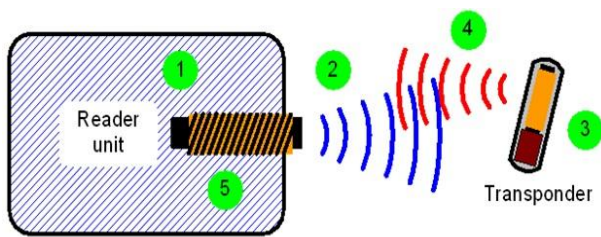

Fig 7.2: Representation of RFID System.

## 7.3 RFID TAGS

This technology is similar in concept to a cell phone. RFID is a broad term for technologies that use radio waves to automatically identify people or objects. There are several methods of identification, but the most common is to store a serial number that identifies a person or object, and perhaps other information, on a microchip that is attached to an antenna (the chip and the antenna together are called an RFID transponder or an RFID tag). The antenna enables the chip to transmit the identification information to a reader. The reader converts the radio waves

reflected back from the RFID tag into digital information that can then be passed on to computers that can make use of it .

### 7.3.1 TYPES OF RFID TAGS

- Active
- passive tags

#### PASSIVE RFID TAGS

Passive RFID tags have no internal power supply. The minute electrical current induced in the antenna by the incoming radio frequency signal provides just enough power for the CMOS integrated circuit in the tag to power up and transmit a response. Most passive tags signal by backscattering the carrier wave from the reader. This means that the antenna has to be designed both to collect power from the incoming signal and also to transmit the outbound backscatter signal. The response of a passive RFID tag is not necessarily just an ID number; the tag chip can contain non-volatile, possibly writable EEPROM for storing data. Example of passive tag shown in fig 7.3.1



Fig 7.3.1 RFID passive tag

The advantages of a passive tag are:

- The tag functions without a battery; these tags have a useful life of twenty years or more.
- The tag is typically much less expensive to manufacture

The tag is much smaller (some tags are the size of a grain of rice). These tags have almost unlimited applications in consumer goods and other areas.

### ACTIVE RFID TAGS

Unlike passive RFID tags, active RFID tags have their own internal power source, which is used to power the integrated circuits and broadcast the signal to the reader. Active tags are typically much more reliable (i.e. fewer errors) than passive tags due to the ability for active tags to conduct a "session" with a reader. In turn, they are generally bigger and more expensive to manufacture, and their potential shelf life is much shorter. Many active tags today have practical ranges of hundreds of meters, and a battery life of up to 10 years. Some active RFID tags include sensors such as temperature logging which have been used to monitor the temperature of perishable goods like fresh produce or certain pharmaceutical products. Active tags typically have much longer range (approximately 500 m/1500 feet) and larger memories than passive tags, as well as the ability to store additional information sent by the transceiver.

### 7.4 LCD

LCDs can add a lot to your application in terms of providing a useful interface for the user, debugging an application or just giving it a "professional" look. The most common type of LCD controller is the Hitachi 44780, which provides a relatively simple interface between a processor and

an LCD. Inexperienced designers do often not attempt using this interface and programmers because it is difficult to find good documentation on the interface, initializing the interface can be a problem and the displays themselves are expensive.

LCD has single line display, Two-line display, four line display. Every line has 16 characters.

### 7.5 ZIGBEE PRO

The XBee and XBee Pro radio is made by Digi (formerly Maxstream) which is shipped with firmware implementing the IEEE 802.15.4 protocol. These modules use the IEEE 802.15.4 networking protocol for fast point-to-multipoint or peer-to-peer networking. However, the most different part between XBee and XBee Pro is they have different cover distance range for communicate with own module. XBee can be covers around 30m at indoor and 100m at outdoor. Inversely, XBee Pro can cover higher distance range than XBee which is 100m at indoor and 1500m at outdoor. Both devices that has a UART interface can connect directly from microcontroller to pins of RF Module (XBee/XBee Pro). Using UART interface, we can use this wireless devices to communicate between microcontroller to microcontroller (two PICs) or between PC to microcontroller.[4]

### 8. ADVANTAGES

1. Locating products through system search, which then displays a map with both cart and product location thus avoiding the waste of time searching for products that often change place.
2. The offer of multiple navigation trajectories inside **the supermarket based on the consumer's shopping list or on system's suggestion.**
3. Shopping list suggestions based on previous visits by monitoring navigational trajectories inside the supermarket and choice of products, something

which helps the consumer remember any needed product.

### 9. APPLICATIONS

1. We implement to simplify the billing process, make it swift & increase the security using RFID technique. This will take the overall shopping experience to a different level.
2. Automatic billing of products by using RFID technique will be a more viable option in the future.
3. The system based on RFID technique is efficient, compact and shows promising performance.

### 10. REFERENCES

- [1] J.Suryaprasad, B.O.P. Kumar, D. Roopa and A.K. Arjun, "A Novel Low-Cost **Intelligent Shopping Cart**", IEEE 2nd International Conference on Networked Embedded Systems for Enterprise Applications, pp.1-4, 2011.
- [2] Ankit Anil Aggarwal, "RFID Based Automatic Shopping Cart", The International Institute for Science, Technology and Education journal on Control Theory and Informatics ,vol.1, no.1, 2011.
- [3] Varsha Jalkote, Alay Patel, Vijaya Gawande, Manish Bharadia<sup>4</sup>, Gitanjali R. Shinde<sup>5</sup>, Aaradhana A Deshmukh Student , SKNCOE, University of PUNE , Maharashtra, INDIA Asst. Professor, University of PUNE , Maharashtra, INDIA.
- [4] Ergen, S. C., "ZigBee/IEEE 802.15.4 Summary," EECS Berkely, September 2004.