

COMPENSATION OF VOLTAGE SAG AND SWELL USING DYNAMIC VOLTAGE RESTORER

K. Satyanarayana Raju¹, Avala Ramulu²

¹ Student, Department of EEE, GIT, GITAM University, Andhra Pradesh, India.

² Associate Professor, Department of EEE, GIT, GITAM University, Andhra Pradesh, India.

Abstract - Voltage sags and swells are the most significant disturbances to the system which may bring great economic losses to the sensitive customers. To solve this problem, installation of custom power device has become necessary. Dynamic Voltage Restorer (DVR), one of the custom power device is being installed in the power system at both transmission and distribution level in order to provide efficient solution to this problem of voltage sags/swells. In this paper, a new model for DVR using sinusoidal pulse width modulation technique with PI Controller is being proposed for compensation of sag/swell. Proposed model is simulated in MATLAB-Simulink and simulation results prove that the proposed model is the most effective solution for the problem of voltage sag/swell.

Key Words: Voltage sag, Voltage swell, Sinusoidal Pulse Width Modulation Technique and Dynamic Voltage Restorer.

1. INTRODUCTION

In modern technology, there are two major challenges that power system must deal with: one is voltage fluctuations and the other is short circuit faults. Nowadays, many power loads have become more sensitive to the disturbances due to voltage fluctuations that are produced because of wide use of non-linear loads. Because of these disturbances or fluctuations quality of power being distributed or transmitted has become low. Faults in power system can cause voltage sag or swell in the entire system or major part of it. In addition, harmonics, voltage transients, flickers are also one of the voltage quality problems [1].

Voltage sag can occur at any instant of time ranging from 0.1 to 0.9 p.u and that lasts for half a cycle to one minute [2]. Voltage sag can be either balanced or unbalanced which mainly depends on type of fault. The main sources of voltage sag are any type of fault in power system or by the starting of

large motor loads. Mainly, voltage sags are considered as major threats to the power quality. Similarly voltage swells occurs at any instant of time ranging from 1.1 to 1.8 p.u and that lasts for half a cycle to one minute. But voltage swells are less frequent compared to that of voltage sags which are mainly produced because of sudden switching off of large loads or energization of capacitor banks [3].

Due to these faults, under full load conditions, it may cause severe or high voltage drops in the system. Due to these disturbances, system may undergo shutdown or fail including large voltage and current imbalances in the system. Various techniques can be adopted or used by the customer in order to mitigate these voltage sags / swells to have better quality of power supply to the equipment for its effective functioning. But, the effects that are caused by the voltage sag or swell to the equipment may be expensive to the customer. But, there are many techniques available for compensation of voltage sag and swell, in which installation of custom power device is the adequate method for mitigation of voltage sag and swell. This concept of installing custom power device is being introduced by N.G Hingorani in 1995. Installation of custom power device means use of power electronic controllers in power system to deal with various power quality problems. The main intention to deal with various power quality problems is to ensure the users get a good quality and trust worthy supply.

There are many custom power devices available for providing solution to the different power quality problems, but DVR is considered as the most apt solution for the mitigation of voltage sag and swells in the power system. Other custom power devices available for solution of power quality problems are Distribution STATic COMPensator (DSTATCOM), Superconducting Magnet Energy Storage (SMES), Static VAR Compensator (SVC), Static VAR Generator (SVG), Thyristor Controlled Reactor (TCR), Dynamic Voltage Restorer (DVR), Uninterruptable Power Supply (UPS) etc. [4] When compared to all custom devices mentioned above, DVR is the best solution for effective and

efficient compensation of voltage sag and swell because of the following reasons, they are:

- (a) Compared to SVC, DVR has better capability of controlling active power flow.
- (b) Because of its high maintenance and replacement cost, DVR is preferred over UPS.
- (c) SMES is high cost and has lower energy capacity compared to that of the DVR.
- (d) DVR is smaller in size and lower cost when compared to DSTATCOM.

On considering all the above reasons, DVR is considered as better solution for mitigation of voltage sag and swell.

In this paper, requirement of DVR for mitigation of voltage sag and swell is clearly explained and corresponding model for its operation is proposed and is being simulated using MATLAB-Simulink. Simulink results are clearly illustrated which depicts the importance of DVR.

2. PROPOSED MODEL

Dynamic Voltage Restorer is a series connected power electronic device which injects missing voltage into the system to regulate voltage at the load end in case of any power quality issues like voltage sag or swell in the system[5]. The basic operation of DVR is as shown in figure 1.

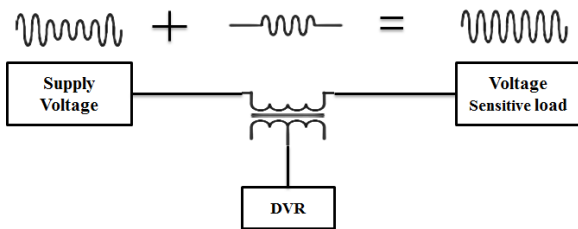

Fig -1: Operating principle of DVR.

The main principle behind working of DVR is that it injects dynamically controlled voltage V_{dvr} generated by forced commutated converter in series to the bus voltage by means of a booster transformer. There are different methodologies available for operating DVR which mainly differs in triggering the pulses for the inverter circuit. In this paper, sinusoidal pulse width modulation technique is being used for triggering the pulses of inverter circuit. DVR mainly includes injection / booster transformer, LC or harmonic filter, inverter circuit and a energy storage device with a control system [6].

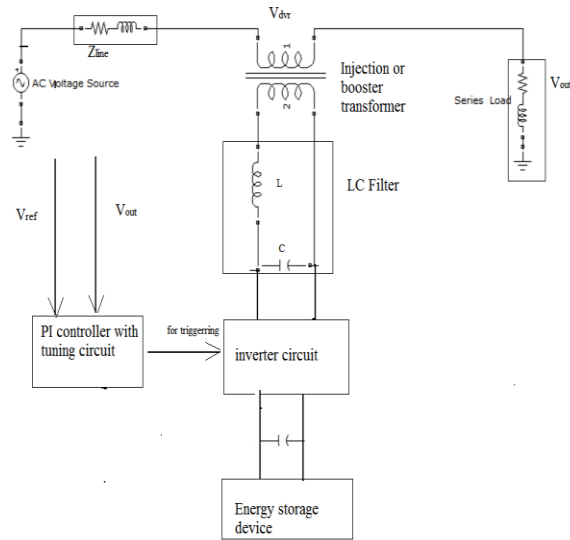

Fig -2: Block diagram of DVR for Proposed Model.

The basic block diagram of DVR illustrating the methodology designed in proposed model is as shown in figure 2[1]. There are three different modes of operation of DVR namely protection mode, standby mode and injection mode [3].

Simulation model for the DVR is as shown in figure 3.

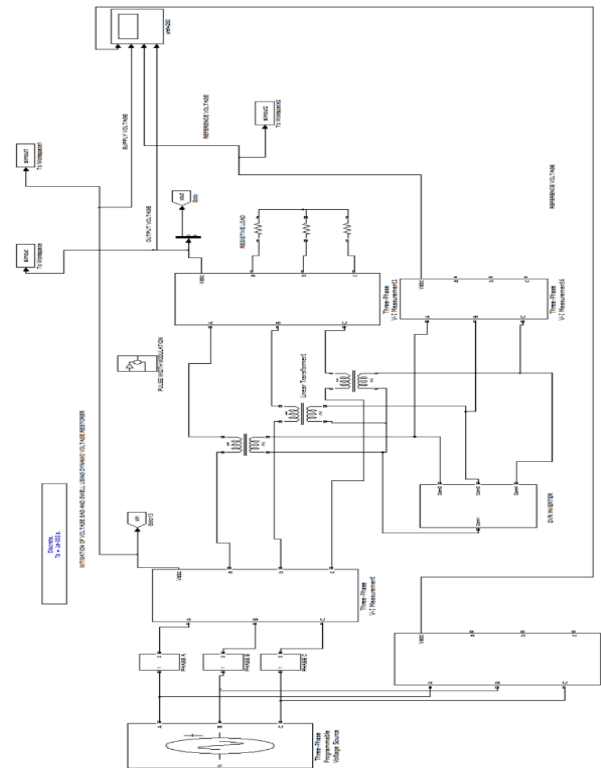

Fig -3: Proposed Simulation Model for DVR.

The different subsystems designed in the proposed model are as follows:

2.1 Voltage sag / swell creation

Figure 4 shows the Simulink model for voltage sag / swell creation.

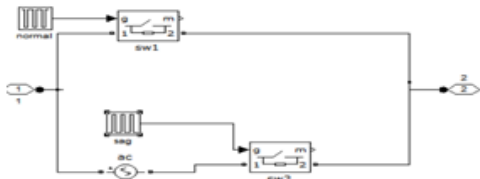

Fig -4: Simulink model for sag/swell creation.

2.2 Inverter circuit

Figure 5 shows the Simulink model of DVR inverter circuit. MOSFET devices are being used for Inverter circuit.

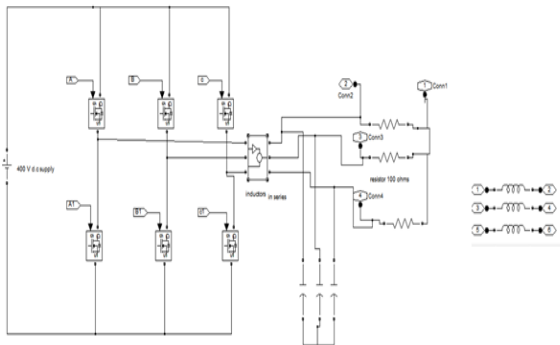

Fig -5: Inverter circuit for proposed model of DVR.

4. CONTROL SCHEME

Figure 6 shows the control scheme adopted for the proposed DVR model [7]. Static power converters are used to produce an ac output voltage from a dc power supply. This methodology is mostly used in the uninterruptible power supplies (UPS), flexible AC transmission system (FACTS). These can be considered as voltage source inverter based on

the output voltage waveforms, as these outputs behave as a voltage source naturally these topologies are most widely used. The sinusoidal pulse width modulation (SPWM) technique is more effective in reducing the lower order harmonic with proper choice of the switching patterns for power devices, certain harmonics can be eliminated [8].

In the proposed control scheme, firstly the output voltage and the reference voltage are being tuned by performing series of operation as shown in the figure 6. After tuning the both waveforms now the two signals are being compared and the difference is given to the PI controller block which produces constant output that is being fed to SPWM circuit to generate triggering pulses for the inverter circuit. With the help of the SPWM technique, valves in same branch are not triggered at the same time. In normal conditions as there will be no difference between the reference and the output voltage, the output of PI controller will be zero which clearly says that no triggering pulses will be generated by SPWM block for the inverter.

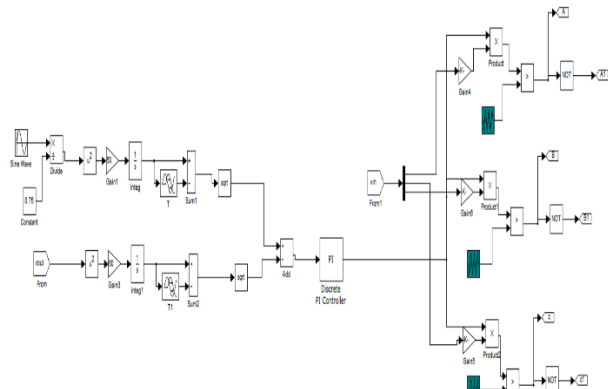

Fig -6: SPWM Technique for Proposed Model.

5. WORKING OF PROPOSED MODEL

For mitigation of voltage sag and swells the circuit is designed (shown in Figure2) so as to continuously monitor the voltage levels at the load side. During normal conditions load will be provided with the rated / desired power (at rated voltage) [5]. The simulation model of the circuit is shown in figure3.

To justify the operation of the proposed model for voltage sag mitigation, we are generating a sag voltage of 30% of rated rms voltage. This is achieved by connecting ideal switches that will be triggered by repeating sequence system. Under normal operation, the gate of ideal switch is triggered that offers nothing but the short circuit path. But during voltage sag condition, gate of ideal switch is triggered

consisting of a voltage source of required level of sag connected in opposition to the main voltage source.

For flexibility, this sag creation has been done to individual phases because we can't be sure that the sag will be created on all the phases simultaneously. Sag may occur even for a single phase or all the phases but not at the same time. However for the sake of effective explanation sag is created to all the phases simultaneously in the same time interval.

Using a voltage measurement block we are detecting the voltage available to the load continuously. Since there is a decrease in the voltage we are tuning this voltage with a reference voltage provided that the reference voltage is same as that of actual source voltage under normal conditions. After tuning, using sinusoidal pulse width modulation technique we are generating triggering pulses that will be given to the voltage source inverter (VSI). Basing on the level of output voltage at load, triggering pulses will be given to VSI in such a way that the triggering is done between the path (providing line voltage) of much positive and much negative voltage value containing phases. By the action of inverter we are generating a voltage to be compensated that is taken across a load. This load voltage will pass through the injection / booster transformer to aid the fault voltage (sag voltage). This will be done continuously unless and until the load voltage meets the rated voltage. Once the rated voltage is achieved at the load the tuning process will be repeated, since there is no difference in the voltages there won't be generation of gate triggering pulses which will be going to be given to VSI compensating voltage won't be generated to pass through injection transformer. Thus, there won't be any further increase of voltage beyond the rated value.

5. SIMULATION RESULTS AND ANALYSIS

5.1 Voltage sag:

The simulation result of 30% voltage sag in supply voltage between time period 1 to 1.8 seconds with a dip of 100 V is shown in figure 7(a). The rms voltage is taken as 330V. Figure 7(b) shows the injected voltage required to compensate the voltage sag. Figure 7(c) shows the output voltage after compensation by the proposed DVR model.

5.2 Voltage swell:

The simulation result of 30% voltage swell in supply voltage between time period 1 to 1.8 seconds with a swell of 100 V is shown in figure 8(a). The rms voltage is taken as 330V. Figure 8(b) shows the injected voltage required to compensate the voltage sag. Figure 8(c) shows the output voltage after compensation by the proposed DVR model.

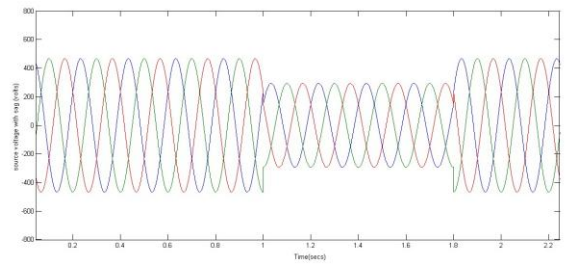

(a)

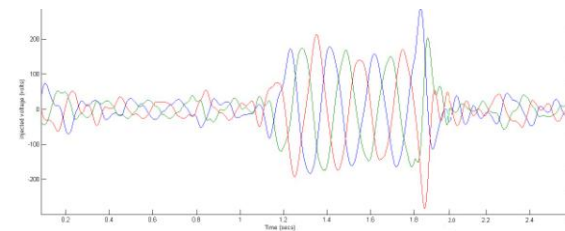

(b)

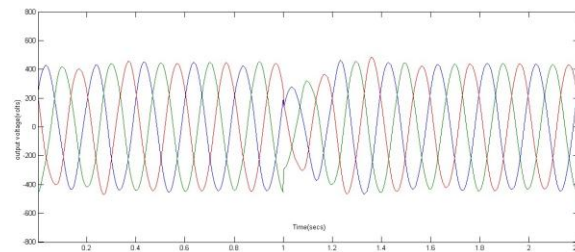

(c)

Fig -7: (a) supply voltage with sag. (b) Injected voltage. (c) Supply voltage.

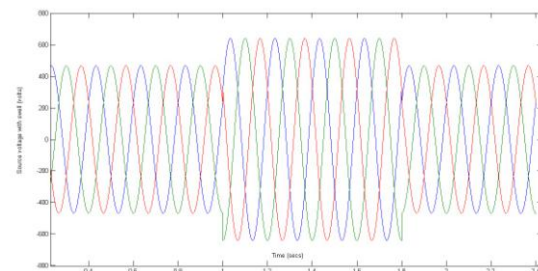

(a)

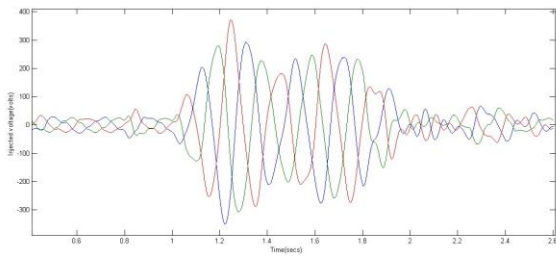

(b)

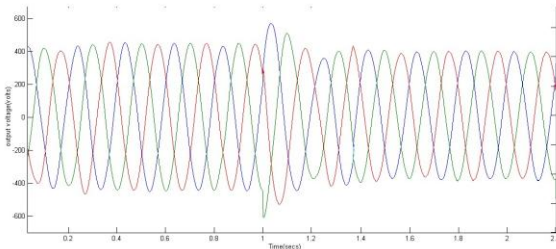

(c)

Fig -8: (a) supply voltage with swell. (b) Injected voltage. (c) Supply voltage.

6. CONCLUSIONS

In this paper, the modeling and simulation of a DVR with Sinusoidal PWM based controller for 3Φ , 330V (rms), 50Hz distribution system has been developed by using Mat lab/Simulink.

DVRs are effective recent cost power devices for voltage sags and swells compensation. They inject the appropriate voltage component to correct rapidly any anomaly in the supply voltage to keep the load voltage balanced and constant at the nominal value. The simulation results show that the DVR compensates the sag and swell effectively and provides excellent voltage regulation. The control system implemented here is PI controller technique which is a scaled error between supply side of the DVR and its set reference value. The main advantage of this proposed model is that it can be used for any type of load in compensation of voltage sag/swell by removing voltage sag/swell creation block and replacing the load with desired load.

REFERENCES

[1] Wang jing, Xuaiqin, Shen yveyue "A survey on control strategies of dynamic voltage restorer", IEEE transactions, 2008.

- [2] "Recommended practice for monitoring electric power quality", IEEE std., pp-1159-1995.
- [3] Deepa Francis, Tomson Thomas "Mitigation of voltage sag and swell using dynamic voltage restorer", International conference on magnetics, machines and drives (AICERA-2014 ICMMD).
- [4] N.G. Hingorani, Laszlo Gyugyi, "understanding FACTS, concepts and technology of flexible AC transmission systems."
- [5] M.Arun Bhaskar, Dr.S.S Dash, C.Subramani, M.Jagadeesh Kumar, "Voltage quality improvement using DVR", International conference on recent trends in information, telecommunication and computing, pp-378-380, 2010.
- [6] Priyanka Kamari, Vijay Kumar Garg "simulation of dynamic voltage restorer using mat lab to enhance power quality in distribution system", international journal of engineering research and applications (IJERA), vol 3, issue 4, pp-1436-1441, jul-aug 2013.
- [7] J.R Espinoza, "power electronics handbook", CA: academic press, chapter 14- inverters, 2001.
- [8] T.Ohnishi and H. Okitsu, "A novel PWM technique for three phase inverter / converter," international power electronics conference, pp-384-395, 1983.

BIOGRAPHIES



K. Satyanarayana Raju, received B.Tech degree from GITAM Institute of Technology, GITAM University, Visakhapatnam in 2015. He passed out the degree with Distinction. His areas of interest are in fields of Power systems, Control systems and Power electronics.



Avala Ramulu, received the B.Tech degree from JNTU college of Engineering, Kakinada in 1984. He worked as Lecturer from 1986 to 1988 in MVJCE, Bangalore. He received his M.Tech degree from the Mysore University in 1990. Currently he works as Associate Professor in Electrical & Electronics Engineering at the GITAM University, Visakhapatnam. At present he is pursuing Ph.D. at Vellore Institute of Technology (VIT) University. His main interests are in the fields of Power Electronics and Control of Electrical Drives.