

Models for MATLAB and XSG Simulink based Edge Detection Operations

Dushyant Mankar¹, Prof. S.S.Mungona²

¹M.E. Student, Department of Electronics and Tele-communication, Sipna college of Engineering and Technology, S.G.B. Amravati University, Amravati (Maharashtra State), India.

² Assistant Professor, Department of Electronics and Tele-communication, Sipna college of Engineering and Technology, S.G.B. Amravati University, Amravati(Maharashtra State),India.

Abstract - Edge detection is necessary for extraction of information for further image processing operation. Many computer vision application use edge detectors as primary operators before high level image processing. Several algorithms are available for edge detection which makes use of derivative approach. Prewitt, sobel, canny are some of the examples of edge detection methods. In this paper edge detection techniques are implemented using MATLAB based Simulink model and then using XSG based model. Prototype of Application Specific Integrated Circuit [ASIC] can be obtained by FPGA based implementation of edge detection algorithm for XSG based Simulink model. Comparative analysis using software and hardware is done. Instead of using traditional way of programming FPGA, System Generator is used for programming and modeling FPGA. XSG has an integrated design flow to move directly to the bit stream file from simulink design environment which is necessary for programming the FPGA.

its neighborhood. Image processing operations can be applied to the whole image or its parts.

The edge is given by its length, slope angle, and coordinate of the slope midpoint. Amidst many ways for doing edge detection, the majority may be grouped into two categories, Gradient and Laplacian based approach. The basic Edge detection operator is a gradient operator that gives the level of variance between different pixels. It is calculated by forming a matrix centered on a pixel chosen as the center of the matrix area. If the value of the matrix area is above a given threshold, then the middle pixel is considered as an edge. Well known examples of gradient based edge detectors are Prewitt and Sobel operators. All the gradient based algorithms have Kernel that gives the strength of the slope in directions that are orthogonal to each other, generally horizontal and vertical. Classically, Edge detection algorithms have been implemented over software plat-form. With advancement in the VLSI technology hardware implementation has become an attractive alternative.

Key Words: ASIC, Sobel , MATLAB, XSG, FPGA..

1. INTRODUCTION

Edge detection is an imperative preprocessing step in image processing. Edge detection is a set of mathematical rules with gives the point in a image where the brightness of image has discontinuities. The need to find the sharp changes in an image is to get all the important event and property changes. In many applications it is essential to find boundaries of objects that appear in images. It is the first step of image analysis. The purpose of edge detection is to find the information about the shapes and the reflectance in an image. Low level image processing operations like image segmentation using edge detection and feature extraction helps us to analyze and take decision in various applications. It processes an image pixel by pixel and over

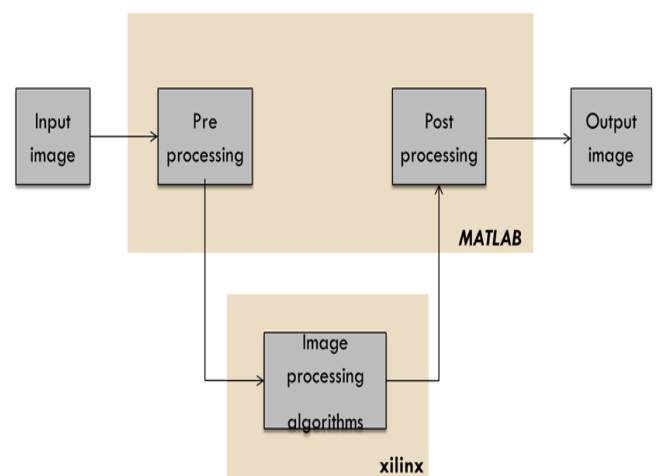

Fig -1: Basic Image Propagation Block Diagram

2. PROPOSED WORK

2.1 Edge detection using MATLAB Simulink based model.

This model is designed in MATLAB environment. High pass filters is used for computing Horizontal and Vertical Gradient. Each gradient output is then added to find an edge.

Steps for edge detection using MATLAB Simulink.

1. Performs two-dimensional FIR filtering of input matrix I using filter coefficient matrix H.
2. The FIR filter is basically a filtering based on convolution.
3. The convolution of image matrix with mask of different edge detection operators like Prewitt, Sobel.
4. The output is compared with threshold and edge detected image is obtained.

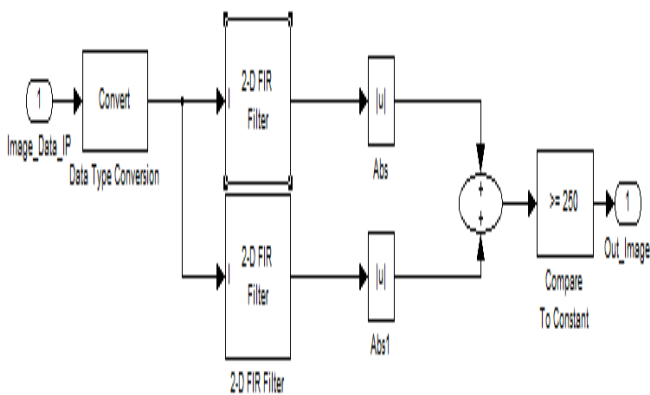

Fig -2: Matlab Simulink model.

In the above model ,the horizontal and vertical window can be selected according to Prewitt and sobel window.

Disadvantage : The main reason for obtaining alternate design for above system is that it cannot be implemented over hardware platform. The Simulink blocks used from Matlab Simulink environment is not hardware synthesizable.

Therefore there is need for alternate design for edge detection using hardware synthesizable blocks which can be done using Xilinx System Generator Block sets.

2.2 Algorithm for edge detection using XSG simulink based model.

- Step 1: Read the Input Image Matrix using Image from file block.
- Step 2: The Input Image Matrix is resized to 256*256 matrix form.
- Step 3: The Input Pre-Processing steps are performed for converting input matrix from 2D to 1D.
- Step 4: The Input Image Matrix and mask for Sobel operator are convolved with each other.
- Step 5: The convolution of the Input Image Matrix with Sobel gradient mask in the Horizontal direction is done.
- Step 6: The convolution of the Input Image Matrix with Sobel gradient mask in the Vertical direction is done.
- Step 7: The value obtained in steps 5 and steps 6 are converted into absolute values and then added.
 $G = \text{abs}[G_x] + \text{abs}[G_y]$
- Step 8: The Threshold value namely T is selected for the comparison with G obtained in steps 7.
- Step 9: The computed Gradient Magnitude G is compared with selected threshold T.
- Step 10: If the value of G is greater than T then we mark that pixel as edge.
- Step 11: If the value of G is lesser than T then we leave that pixel and considered the next neighborhood.

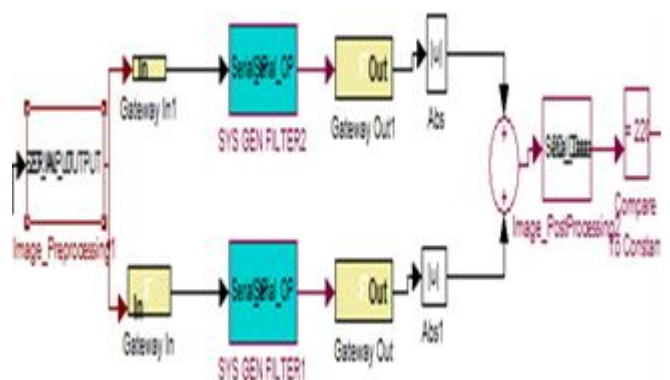

Fig -3: XSG based Simulink design

2.3 Steps for implementing on Spartan-3E FPGA starter kit.

For new compilation target following parameter in dialogue box has to set

- a) Give board name as we want
- b) Set maximum frequency of board
- c) In pin location set location of clock
- d) Boundary scan position set to '1'
- e) Set targetable device
- f) IR length: check after kit is connected once it is detected, go to click install button given below.
- g) After this process is over we get JTAG CO-SIMULATION block at last.
- h) With help of this block we can load over bit stream file into FPGA board and easily analyse our result.

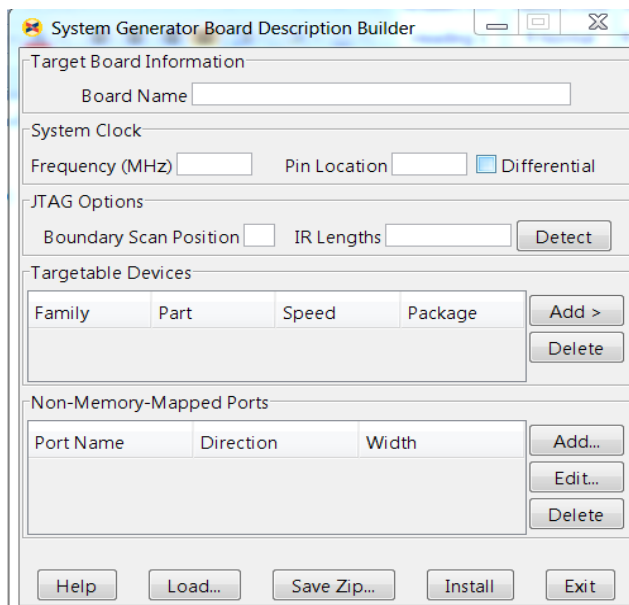

Fig -4: Parameter of Target Board.

3. RESULT



Sr. no.	Input Image	Using Matlab simulink	Using XSG simulink
1.			

Table-1: Output results for MATLAB and XSG base Simulink model

Resources	Used	Available	Utilization
Slices Flip Flop	578	9312	6%
Slices	478	4652	10%
LUT	588	9312	6%
IOB's	39	232	16%
Total Supply Power		0.182W	
Clock Period		4.01ns	

Table-2: Design Summary of XSG model of Sobel Edge Detection

4. CONCLUSIONS

Real time applications are always on hardware platform rather than software. In this paper low level digital image processing technique which is edge detection algorithm over software and hardware platform is proposed. Several edge detection algorithms are available but while implementing those on hardware, the VHDL or Verilog code becomes very bulky. To avoid that tedious work of error correction and debugging of large VHDL code we prefer this Simulink based design. So we are implementing them on hardware platform using Xilinx system generator tool. XSG tool of matlab provides simpler and efficient way of FPGA programming. ASIC prototype is easily obtained using this design.

REFERENCES

1. P R possa ,s a mah mouidi,c valderrama, p mannback, "A multi resolution fpga based archtecthure for real time edge and corner detection Algorithm", IEEE transactions on computers, Jan 2013
2. Yahid Said, Taoufik Saidani, Fethi Smach and Mohamed Atri, Real Time Hardware Co-simulation of Edge Detection for Video Processing System , IEEE 2012.
3. A.Amaricai,O.Boncalo,M.Iordate,B.Marinescu A Moving Window Architecture for HW/SW codesign Based Canny Edge Detection for FPGA, International Conference On Microelectronics,13-16 MAY 2012 (MIEL 2012
4. R. Harinarayan, R. Pannereselvam, M. Mubarak Ali, D. Tripathi, "FeatureExtraction of Digital Aerial Images by FPGA based implementation of edgedetection algorithms", Proceeding of ICETECT, Vol. 29, 2011, pp. 229-233.
5. Christos Kykou,Christos Ttoffis and Theocharis Theocharides,FPGA-ACCELERATE OBJECT DETECTION USING EDGE INFORMATION, International Conference on Field Programmable Logic and Applications,2011
6. Jincheng wu, "Design and Implementation of video image edge dtetection system based on FPGA"(CISP 2010).
7. Mahendra ,Ajith, Ranga "FPGA based compact and flexible architecture for real time embedded vision system"(ICIIS 2009).
8. Alfredo Gardel Vicente, Ignacio Bravo Munoz, Embedded Vision Modules for Tracking and Counting People, IEEE transaction on instrumentation and measurement, vol.58 , no 9, September 2009.
9. www.Xilinx.com

BIOGRAPHIES



Dushyant Mankar
M.E. Student, Department of Electronics and Tele-communication, Sipna college of Engineering and Technology, S.G.B. Amravati University, Amravati (Maharashtra State), India.



Prof. S.S.Mungona
Assistant Professor, Department of Electronics and Tele-communication, Sipna college of Engineering and Technology, S.G.B.Amravati University,Amravati(Maharashtra State),India.