

# COST COMPARISON BETWEEN CONVENTIONAL AND FLAT SLAB STRUCTURES

Amrut Manvi<sup>1</sup>, Sandeep Gouripur<sup>1</sup>, Pooja Sambrekar<sup>1</sup>, Ramanjeetkaur<sup>1</sup>, Dr. Kishor S. Kulkurni<sup>2</sup>

<sup>1</sup> U.G. Students, <sup>2</sup>Assistant Professor, Department of Civil Engineering, *KLES' Dr. M. S. Sheshgiri College of Engineering, Udyambag, Belagavi, Karnataka, India*

**Abstract-** In present era, conventional Reinforced Concrete (RC) frame buildings are commonly used for the construction. The use of flat slab building provides many advantages over conventional RC frame building in terms of architectural flexibility, use of space, easier formwork and shorter construction time.

In the present work conventional and flat slab B+G+3 storey building is considered for cost comparison. The building is considered to be situated in earthquake zone 2. For earthquake loading, the provisions of IS:1893 (Part- 1)-2002 are considered. For modeling and analysis of conventional and flat slab structures, ETABS 09 software is used. The dead load, live load and wind load are considered as per Indian codes 875-1987. The design is carried out as per IS 456-2000 and for reinforcement detailing SP 34 is used.

The investigation shows that, the weight of flat slab structure is less compared to conventional slab structure. The cost of flat slab structure is less by 15.8% as compared to conventional slab. The study concludes, flat slab structures are the best solution for high rise structure as compared to conventional slab structure when compared with cost of material.

**Key Words:** Conventional slab, Flat slab, Multi storey building, ETABS, and Cost comparison.

## 1. INTRODUCTION

With rapid growth in population along with development of industrial and commercial activities rapid urbanization has taken place which has resulted into continues influx of rural people to metro cities. So obviously the horizontal space constraint is reaching an alarming situation for metros. To cope with the situation maximum utilization of space vertically calls for the construction of multi-storey buildings in large

numbers but the question of affordability of the target customers mainly the middle income group of our country necessitates efficient and cost effect design of such buildings.

## Objective of the Study

To investigate the cost effectiveness of flat slab over conventional slab for multi storey building.

## 2. CONVENTIONAL SLAB

Slabs supported on walls or on beams are classified as conventional slab. Conventional slab are generally rectangle in shape, but it can be of any shape such as triangular, circular, trapezoidal, etc. Loads are transferred by the slab by flexural; shear and torsion to the supports such slabs supported on two parallel sides carry loads by bending in the direction perpendicular to the supports. They are known as one way slab and are virtually shallow beam with large width.

Slabs supported on four sides also behave as one way slab if the length is very large as compared to the width of the slab. Rectangular slabs with the length not very large as compared to width or square slab supported on four sides carrying loads by bending in two perpendicular directions such slabs are known as two way slabs.

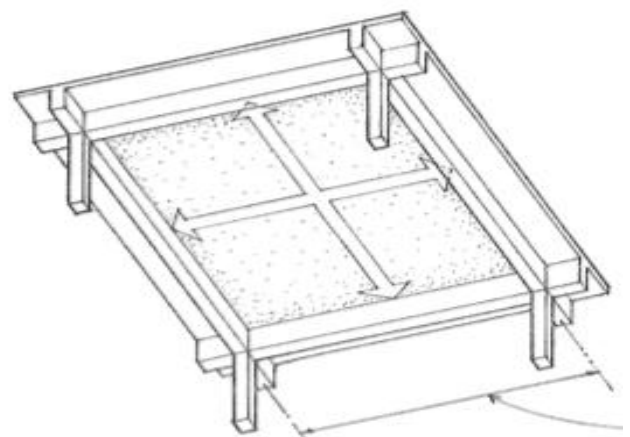

Fig. 1: Typical Conventional Slab

### 3. FLAT SLAB

Common practice of design and construction is to support the slabs by beams and support the beams by columns. This may be called as beam-slab construction. The beams reduce the available net clear ceiling height. Hence in warehouses, offices and public halls sometimes beams are avoided and slabs are directly supported by columns. These types of construction are aesthetically appealing also. Flat slabs which are directly supported by columns.

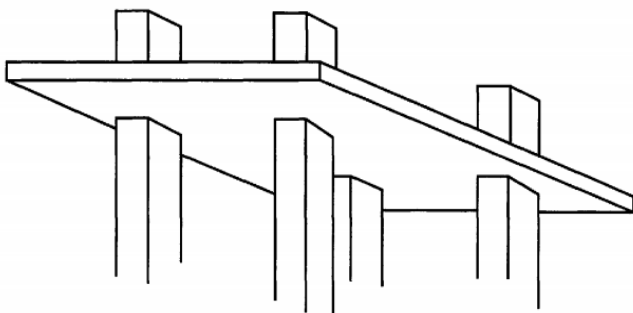

Fig. 2: Typical Flat Slab

### 4. BUILDING MODEL

The study has been carried out with some basic assumptions in design criteria or parameters for (B+G+3) storeyed building for conventional slab as well as flat slab including relevant soil parameters, wind speed, earthquake zone and values of coefficients and acceleration based on available local data and stipulations of Indian Standards codes. The dead load and live load has been considered based on the IS 875 (Part 1&2), wind load is based on IS 875( Part 3). For earthquake loading, the provisions of IS 1893:2002 was considered.

In this study, B+G+3 building models is considered which having floor plan of 30m x 30m in square. The floor plan of is divided into 7.5m x 7.5m bays. Figure 3 shows the details of floor plan adopted for the present study.

The study has been carried out for the two variants.

- B+G+3 conventional slab building and 3.6m floor height.
- B+G+3 flat slab building and 3.6m floor height.

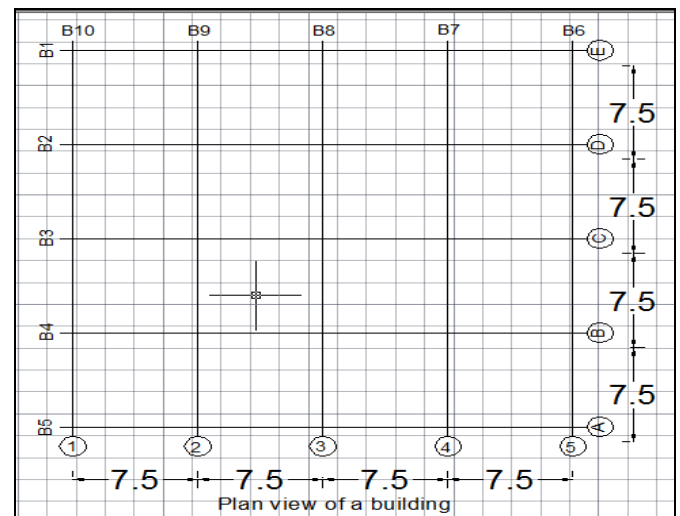

Fig. 3: Detail of Floor Plan

#### 4.1. Specification of Supports

The base nodes of all the columns are restrained against translation and rotation about all the 3 global axes. The fixed support is assigned.

#### 4.2 Load Calculations

The load considered for the following Study is mentioned below which are in accordance with IS 1893(Part 1):2002

##### 1) Dead Load

- i. The self-weight of the structural members is calculated according to the code provision's and taken care in the software.
- ii. Dead load on floor finishing: 1.5kN/m<sup>2</sup>

##### 2) Live Load

- i. Live load on Floor: 3 kN/m<sup>2</sup>
- ii. Live load on Roof: 3 kN/m<sup>2</sup>

##### 3) Seismic Load

- i. Seismic Zone : Zone-II (As per IS 1893(Part-1): 2002
- ii. Type of Structure: Ordinary RC Moment Resisting Frame IS 1893(Part1): 2002.
- iii. Damping ratio: 5% for RC frame structure.
- iv. Seismic zone factor (Z): 0.16 (Table 2 of IS 1893(Part-1): 2002.
- v. Importance factor (I): 1 (Table 6 of IS 1893(Part-1): 2002.
- vi. Response reduction factor (R): 5.0 (Table 7 of IS 1893(Part-1): 2002.

- vii. Fundamental natural period :  $0.075 h^{0.75}$  for RC frame building of vibration ( $T_a$ ) As per IS 1893(Part-1): 2002.
- viii. Foundation soil type : Type-1(Hard Soil), Type-2(Medium Soil), and Type-3(Soft Soil) (As per IS 1893(Part-1):2002.

### 4.3 Material Properties

The properties of material used given in Table 1.

Table 1: Material properties

Grade of Concrete	M25, M20
Density of Concrete	25kN/m <sup>3</sup>
Modulus of Elasticity of concrete	$5000\sqrt{f_{ck}}$ (IS 456:2000)
Grade of Steel	Fe 500 HYSD

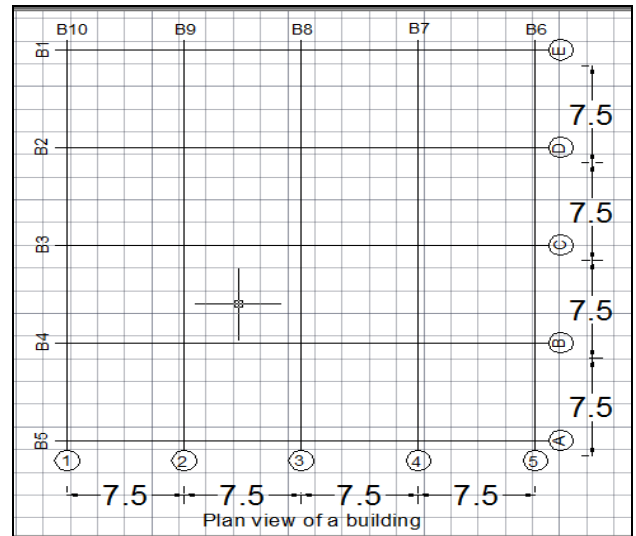

### 5. PROCEDURE FOR MODELING AND ANALYSIS OF FRAMED STRUCTURE USING ETABS

The modeling of the reinforced concrete structure has been done using commercially available structural software 'ETAB 2013'. Member dimension adopted for modeling are presented in Table 2. Step by step procedure is adopted in 'ETAB' to analyze the building for gravity and seismic loads.

Table 2: Member dimensions

Conventional Slab	
Slab thickness	250 mm
Size of beam	230 mm × 750 mm
Column size	300 mm × 900 mm
Flat Slab	
Slab thickness	250 mm
Size of rib beam	230 mm × 600 mm
Column size	230 mm × 750 mm, 300mm× 750mm

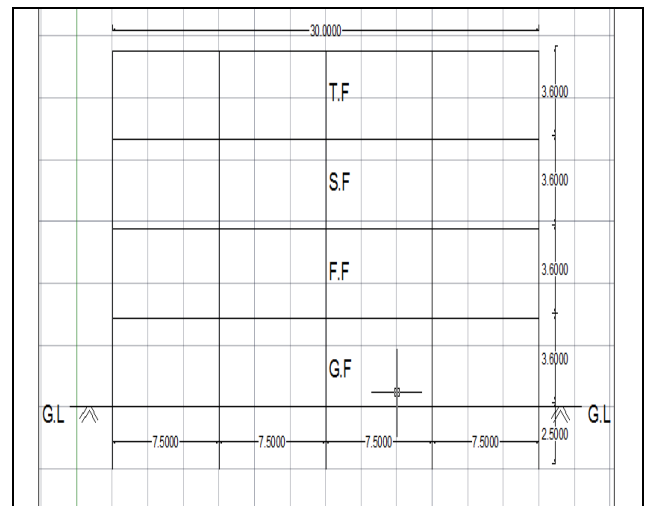

Fig. 4: Plan and elevation view of building

### 6. RESULTS AND CONCLUSION

#### 6.1 Estimation and costing

From the analysis of structure, area of reinforcement has been obtained. Based on area of reinforcement the number and size of bar have been finalized. The IS standard detailing is used to find out the length required. Market rates have been used to find out the total cost of steel reinforcement and concrete used in various elements of structures. In the present study to find out cost of structure rate of steel and concrete is considered Rs. 50 per kg and Rs. 4000 per m<sup>3</sup> respectively.

Figure 4 shows plan and elevation of building adopted for this study. Detailed step by step procedure adopted for modeling and analysis is presented below.

## 6.2 Cost Comparisons

Figure 5-10 shows the variation in quantity of steel, and quantity of concrete and cost between conventional and flat slab framed structure.

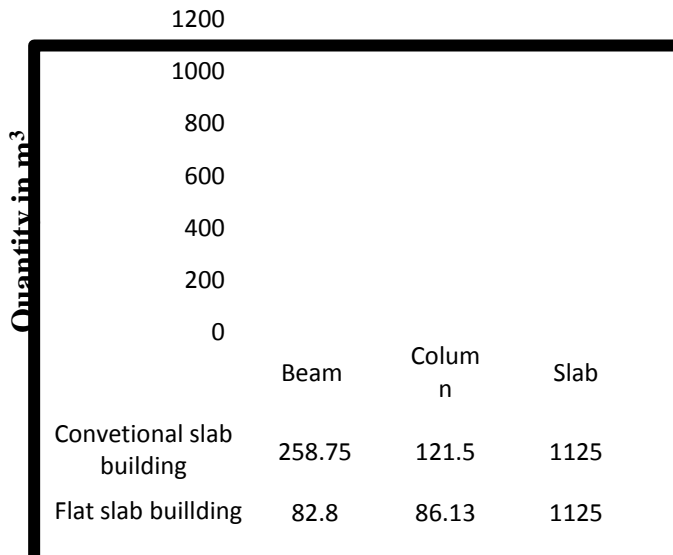

Fig. 5: Quantity of Concrete Variation for conventional and flat slab framed structure

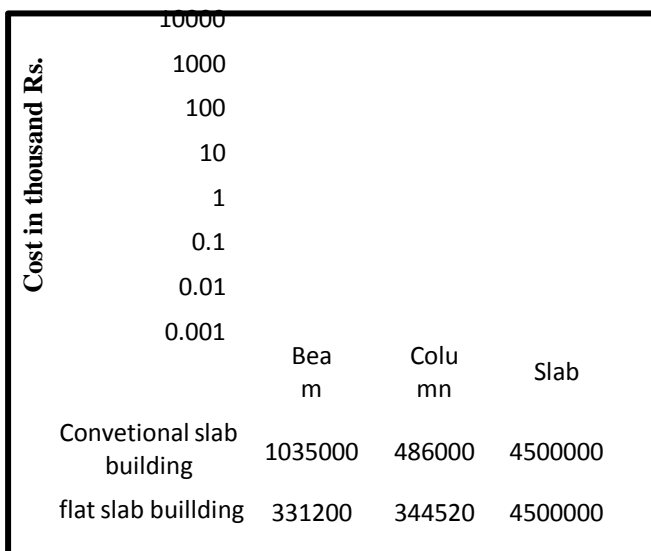

Fig. 6: Cost of Concrete Variation for conventional and flat slab framed structure

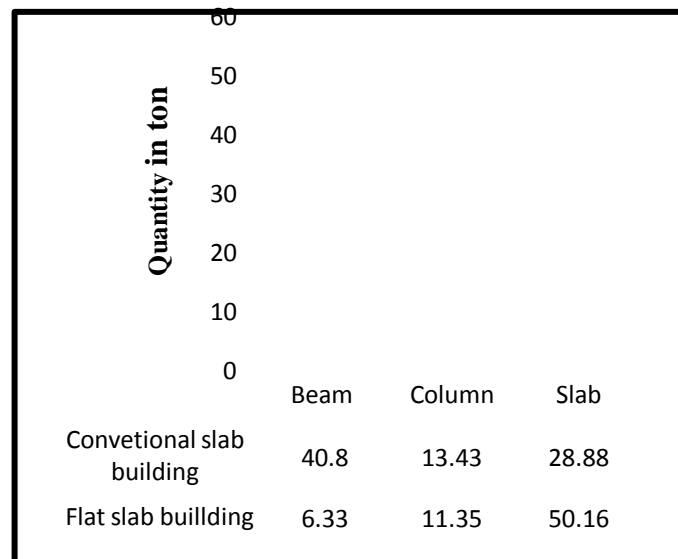

Fig. 7: Quantity of Steel Variation For conventional and flat slab framed structure

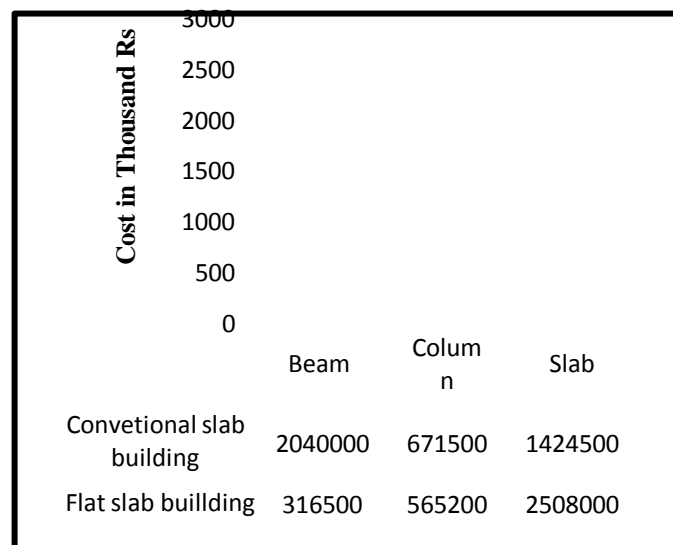

Fig. 8: Cost of Steel Variation For conventional and flat slab framed structure

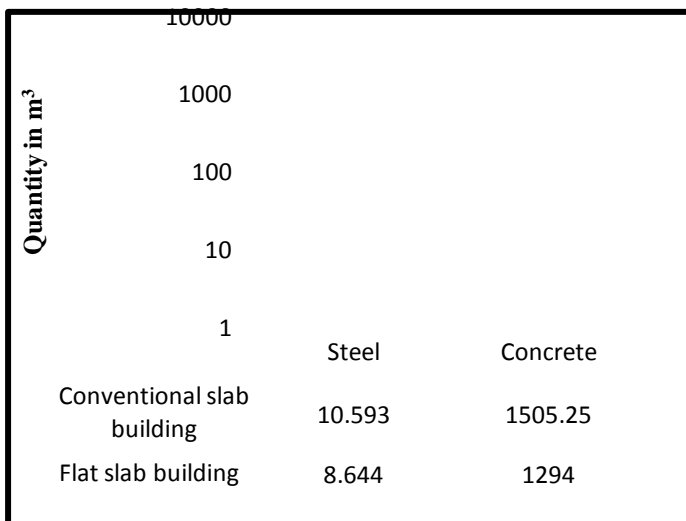

Fig. 9: Total Quantity of Steel and Concrete Variation For conventional and flat slab framed structure

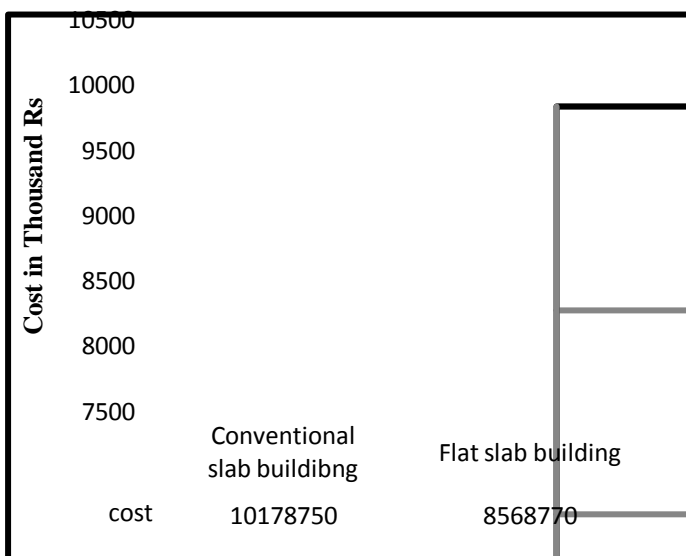

Fig. 10: Total Cost of Steel and Concrete Variation For conventional and flat slab framed structure

From Fig. 5 and 6 it is clear that the quantity and cost of concrete of beam and column for flat slab structure is 68.0 % and 29.1 % less than conventional slab structure respectively, but quantity and cost of concrete for slab is same in both the structures.

From Figure 7 and 8 it is clear that the quantity and cost of steel of beam and column for flat slab structure is 84.48% and 15.48% less than conventional slab structure

respectively, but quantity and cost of concrete and steel for conventional slab is 42.42% less than flat slab.

From Figure 9 and 10 it is clear that the quantity and cost of steel and concrete for flat slab structure is 15.8% less than the conventional slab structure.

### 9. CONCLUSIONS

The comparative study of conventional and flat slab framed structure (B+G+3) is presented. The parameters considered are quantity and cost of beam, column and slab. Thus, based on the analysis the following conclusions are drawn.

Weight of Flat slab structure is quite low as compared to conventional slab structure.

Flat slab structure is more economical than that of conventional slab structure. The cost of flat slab structure is reduced by 15.8% compared to conventional slab structures.

Flat slab structure leads to economic saving, aesthetic view and yet allow the architect from great freedom of form works as compared to conventional slab structure.

Flat slab structures are the best solution for high rise structure as compared to conventional slab structure.

### REFERENCES

[1] IS: 875(Part 1-3)-1987, "Code of practice for design loads(other than earthquake) for buildings and structures", published by Bureau of Indian standards, New Delhi,

[2] IS: 875(Part 1-3)-1987, "Code of practice for design loads", published by Bureau of Indian standards, New Delhi,

[3] IS: 456-2002, "Code of practice for plain and reinforced concrete", published by Bureau of Indian standards, New Delhi,

[4] IS 1893-2002 "Indian standard criteria for earthquake resistant design of structures", published by Bureau of Indian Standards NEW Delhi,.

[5] "SP 34: Handbok on concrete reinforcement and detailing," published by Bureau of Indian standard, New Delhi, 1987.

[6] Agarwal.P and Shirkhande. M., "Earthquake Resistant Design of Structures" Prentice hall of India private ltd. New Delhi, India.

[7] Bryan Stafford Smith Alex coull., "Tall Building Structures analysis and design", published by John Wiley and sons, New York, 2000.

[8] ETAB 2009, "Technical Structural Software and Reference Manual".

[9] K. Navyashree and Sahana T. S., "Use of Flat Slabs In Multi-Storey Commercial Building Situated In High Seismic Zone", International Journal of Research in Engineering and Technology, Vol.03 Issue 08, 2014,pp. 439-451.

[10] N.Krishnaraju"Structural Design and Drawing: Reinforced Concrete and Steel", published by Universities Press (India) Private Limited Hydrabad, 3<sup>rd</sup> edition,

[11] S.S. Patil, Rupali A. Sigi "Flat Slab Construction in India", International Journal of Engineering and Innovation Technology (ISSN:2277-3754), Vol. 3, (10), April 2014, pp. 138-141.

[12] V. L. Shah and S. R. Karve "Illustrated Design of Reinforced Concrete Buildings", published by Structure Publications Pune, India.

[13] Y. H. Luo and A. Durrani "Equivalent Beam Model for Flat-Slab Buildings: Exterior Connections," American Concrete Institute( Structural Journal), vol. 92(2), January 1995, pp. 250-257.

## BIOGRAPHIES



Amrut Manvi, pursuing B.E. in civil Engineering at KLES' Dr M. S. Sheshgiri College of Engineering & Technology, Belagavi.



Pooja Sambrekar, pursuing B.E. in civil Engineering at KLES' Dr M. S. Sheshgiri College of Engineering & Technology, Belagavi.



Sandeep Gouripur, pursuing B.E. in civil Engineering at KLES' Dr M. S. Sheshgiri College of Engineering & Technology, Belagavi.



Ramanjeetkaur, pursuing B.E. in civil Engineering at KLES' Dr M. S. Sheshgiri College of Engineering & Technology, Belagavi.



Dr. Kishor .S. Kulkarni completed his Masters in Structural Engineering and Ph.D in Civil Engineering. Presently he is working as a Assistant Professor in Department of Civil Engineering at KLE'S Dr. M. S. Sheshgiri College of Engineering and Technology, Belgavi. His research interest areas are Structural Engineering, Concrete Technology and Non-Destructive Testing.