

A wideband dual mode horn antenna with tapered discontinuity

Shweta K. Gohil¹, Prof. Usha Neelakantan²

¹ student, communication system engineering (EC),
L. D. College of Engineering, Gujarat, India

² Head Of the Department, Communication System Engineering (EC), L. D. College of Engineering, Gujarat, India

Abstract - The rapid growth in wireless application leads to a great demand for antennas which can utilize the frequency band efficiently (wideband). For that an antenna should have low cross polarization level, low side lobe level and beam symmetry. In order to achieve this, a dual mode conical horn antenna with tapered discontinuity is designed. Designing is carried out in software named HFSS (High Frequency Structure Simulator) which is one of the tools for designing antenna accurately and effectively. In this design, the Excitation of horn at throat region in both dominant TE₁₁ mode and higher order mode TM₁₁ excited at relative amplitude and phase to effect side lobe suppression. Here the horn is made to work for C-band which is more widely used for satellite communication. Mode conversion is carried out with tapered discontinuity which provides gradual change in the radius that makes it suitable for wide range of frequency band. Attempt is to make more efficient compact antenna which will be useful for feeds in Reflector.

Key Words: Dual mode conical horn; mode conversion; TE₁₁; TM₁₁.

1. Introduction

Antennas are devices which transfer signal to waves and propagate through space and is received by the receiving antenna. Dipole antenna has effective reception and transmission but low gain (2.15 dB) lack of directionality & narrow BW. Yagi Uda which is most often found at roof of houses used for TV reception has high gain. (8-14 dB) Log periodic has high gain & Bandwidth as well. Recent development has used antennas for commercial mobile communication for various purposes for cellular like GPS, satellite, wireless LAN etc. More directional antennas used for satellite communication are Horn Antennas. Horn antennas are usually a waveguide of different shape which works as a medium to transit waves to other medium. Horns are used as a feeds for other antennas such as lenses, compound and reflectors. Their features like simple, solid geometry & excellent performance makes it more directives which makes this antenna more useful for different fields and application. Conical horn exhibits axial symmetry which is capable of handling any polarization of exciting dominant Mode TE₁₁ and its wall suited for circular polarization. Although horns exhibit axial symmetry, their beam widths are unequal in principal planes. Therefore Dual mode or multimode horns are designed to overcome these drawbacks

which make antenna suppressed side lobe level, equal beam width and low cross polarization.

2 Literature survey

P.D Potter designed a dual mode horn antenna which can provide complete beam width equalization in all planes, side lobe suppression. Dual mode conical horn, excited at throat region in both dominant mode TE₁₁ & higher order mode TM₁₁ mode.

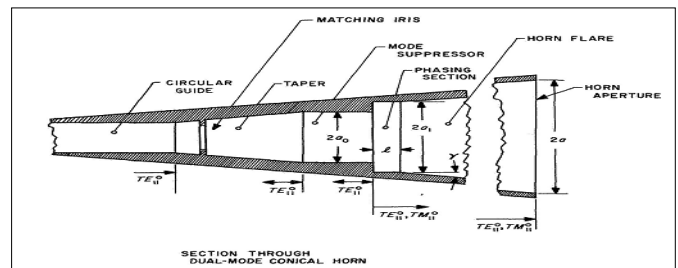

Figure: mode conversion

An increase in horn flare angle will increase aperture phase error. Polar and azimuthal components of TE₁₁ & TM₁₁ are calculated and found that similarity equation makes possible for side lobe cancellation.

E.R.NAGAELBERG showed mode conversion in which Step discontinuity is found to produce relatively constant mode conversion over wideband of frequency. Observed that input standing wave ratio is very low for frequency more than 5% above TM₁₁ mode cut off frequency for oversized waveguide. Distance between successive minima is

$$l = \frac{2\pi}{\beta_{TE} - \beta_{TM}} = \frac{\lambda_{gTE} \cdot \lambda_{gTM}}{\lambda_{gTE} - \lambda_{gTM}}$$

SERGEI P. SKOBELEV found optimum geometry and performance of dual mode horn modification. Excellent agreement was achieved calculation and measurement was achieved when using about $100 \times \frac{(b-b_0)}{\lambda}$ steps. Quadratic

phase error in aperture gives higher gain and smaller beam widths. Every axial symmetrical discontinuity in radial direction will act as transducer. JAE SIK KIM gave a Design of Modified Dual Mode Horn Antenna to Improve E/H-plane Radiation Pattern Symmetry. A modified dual mode horn antenna with rectangular aperture is proposed to improve the E/H-plane radiation pattern symmetry compared to the oversized conventional dual mode horn antenna. To verify

compatibility, the conventional and the proposed dual mode horn antenna are fabricated and investigated at 15 GHz.

3 Dual mode conical horn antenna

For having radiation pattern with good axial beam symmetry and with low level of cross polarization the addition of TM_{11} with dominant mode TE_{11} can be done. This can be achieved when properly phased at Horn aperture which cancels ϕ component of magnetic field in TM_{11} mode due to TE_{11} mode at aperture boundary and that vanishes $H\phi$ and $E\phi$ components. This condition leads to axial symmetry and low cross polarization in radiation pattern. P.D.Potter was first to show that dual mode with suppressed side lobe can be achieved by small change in guide radius from r_1 to r_2 in horn throat.

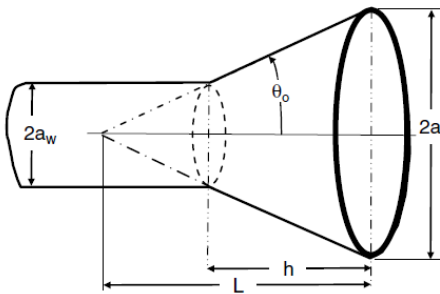

Figure : geometry of conical horn

Value of r_1 must be large enough to support TE_{11} but it must be small enough that TM_{11} is cut off. ($1.84 < Kr_1 < 3.833$) and it is also taken into consideration that proper amount of TM_{11} generated in this way with ratio r_2/r_1 , but r_2 should be not so large that to permit TE_{12} . ($3.83 < Kr_2 < 5.33$) As it follows axial symmetry, TE_{mn} or TM_{mn} modes with $m > 1$ will not be excited. In central region of aperture electric field of TM_{11} mode reinforces that of TE_{11} mode. Near aperture boundary two fields oppose one another. Thus resulting electric field may be heavily tapered in E & H planes.

TE_{11} mode generation θ and ϕ component of E in far field
 TM_{11} mode generates only θ component. It was found that for value of $\alpha=0.65$, E & H plane HPBW are equalized & phase centers in planes are coincident. Other values are near about 0.6 etc., which leads to side lobe suppression. Mode conversion using step discontinuity has been shown Mode conversion coefficient & excitation phase of TM_{11} mode relative to TE_{11} mode on guide centerline in plane of step at $z=0$. If ϕ_{ex} = launch phase ϕ_{ph} = different phase in constant phasing section ϕ_{fl} = different phase of modes in flared section. Condition for reinforcement of electric fields at aperture center.

$$\phi_{ph} + \phi_{fl} - \phi_{ex} = 2m\pi$$

$$\phi_{ph} = l(\beta_{TE} - \beta_{TH})$$

β_{TE} & β_{TH} depends on r_1 (radius)

This type of phasing section is very frequency sensitive due to abrupt change in radius at throat region

Therefore tapered discontinuity used and shown as below:

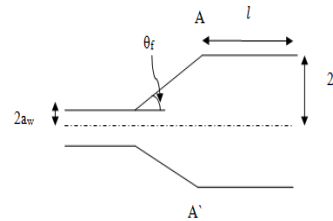

Figure: tapered discontinuity

Conversion from TE_{11} mode to TM_{11} and other higher modes at a relatively large diameter junction between round and conical waveguide was investigated.

$$l(\beta_{TE} - \beta_{TH}) = 3\pi/2$$

Frequency sensitive will make it applicable for narrowband frequency range. And taper discontinuity will make it wideband applicable. For making horn suitable for feeding reflectors, $F/D=0.6$

4. DESIGN SPECIFICATIONS

1. This is designed for c-band (4-8GHz)
2. Operating frequency 5 GHz
3. The input radius contains TE_{11} mode
4. The length of input waveguide
5. Taper length and taper angle
6. The output radius contains $TE_{11} + TM_{11}$ mode
7. The length l of the output waveguide

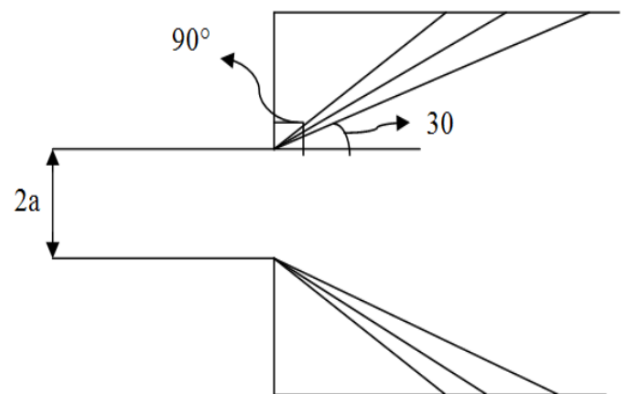

Figure: different taper angles

The horn antenna with different degree taper angles for taper section at $5^\circ, 15^\circ, 30^\circ, 45^\circ, 60^\circ, 75^\circ, 90^\circ$.

The horn antenna with 30 degree taper angle has more power transfer and better return loss than other taper angle. Figure shows the horn antenna with 30 degree in HFSS.

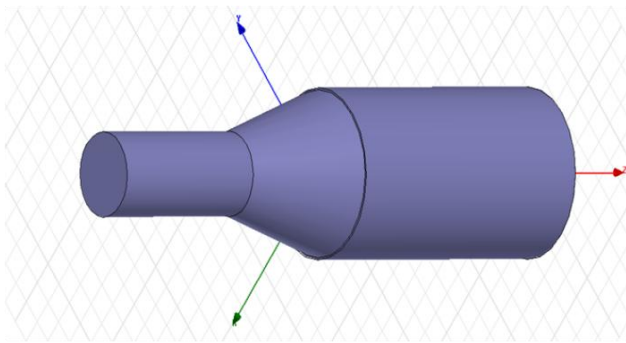

Figure: design in HFSS at 30 ° taper angle

Table: Different taper angle analysis at 3.5 GHz frequency

Degree	Return loss (dB)	Power in TE ₁₁ (in %)	Power in TM ₁₁ (in %)
90	-13.266653	41.47	53.68
75	-14.820010	47.4533	49.11
60	-16.868452	58.59	39.81
45	-20.987361	72.49	26.597
30	-29.357075	86.92	12.77
15	-29.515862	97.04	2.719
5	-33.363599	99.59	0.19

The horn antenna with 90 degree taper angle (step discontinuity) has not good power transfer and return loss.

Design parameter for taper angle 30°

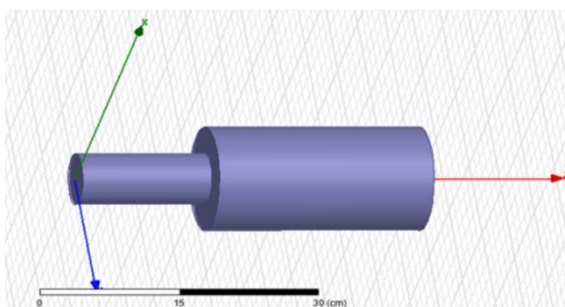
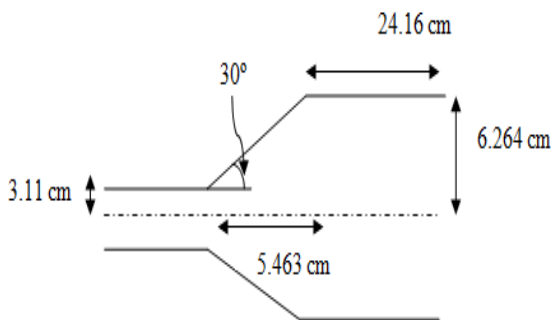

Figure: design in HFSS at 90 ° taper angle

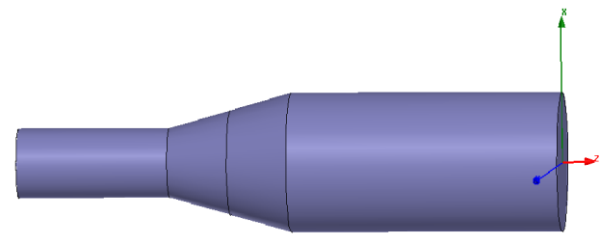

Figure: Design parameter for two taper angle at 15° in HFSS

As discussed the input waveguide should support only the dominant mode (TE₁₁). Therefore the input radius can be obtain as per

$$a = \frac{1.841 \lambda}{2\pi}$$

The second radius of the horn should be decided such that both dominant TE₁₁ and higher order TM₁₁ can propagate through the horn with proper amplitude and phase. Therefore aperture radius

$$b = \frac{3.832 \lambda}{2\pi}$$

The aperture radius of the horn should be decided according to gain such that both dominant TE₁₁ and higher order TM₁₁ can propagate through the horn with proper amplitude and phase. For gain 15 dB the aperture radius

$$G = 20 \log \frac{\pi D}{\lambda}$$

The horn taper angle is 6.25°. The bandwidth ratio is 1.45:1 for horn taper angle is 6.25°.

A front-fed parabolic reflector antenna does not generate cross-polar radiation

The design at 3.5 GHz frequency with F/D ratio is 0.6 and D=10λ

Dual mode conical horn designed in the software at C band (4-8GHz) with different frequencies was observed on rectangular plot of radiation pattern.

Assume the frequency on which we want to make the antenna operative: f

Calculate the cut off wavelength from that :

$$\lambda_c = \frac{c}{f}$$

For radius of guide wavelength: As discussed the input waveguide should support only the dominant mode

(TE₁₁). Therefore the input radius can be obtained from the

$$\text{formula: } a_{TE} : \lambda_c = \frac{2\pi a_{TE}}{1.841}$$

For radius of throat wavelength: The second radius of the horn should be decided such that both dominant TE₁₁ and higher order TM₁₁ can propagate through the horn with proper amplitude and phase. Therefore aperture radius can be obtained from the formula:

$$a_{TM} : \lambda_c = \frac{2\pi a_{TM}}{3.832}$$

For designing the length of the taper waveguide we should have the value of taper angle (θ) which will provide us the length of the taper:

$$\theta = \tan^{-1} \left(\frac{a_{TE} - a_{TM}}{L} \right)$$

Waveguide length with only dominant mode will be

$$\text{calculated as : } \lambda = \frac{2\pi a_{TE}}{1.841}$$

$$\text{After getting the value of: } \lambda_g = \frac{\lambda_c}{\sqrt{1 - (\lambda/\lambda_c)^2}}$$

Now the waveguide with the higher mode and dominant mode will be considered for calculating the length of the waveguide which we will denote as a throat region of the horn: the distance between the successive minima (l)

$$(\beta_{TE} - \beta_{TM}) l = 2\pi$$

Table : at different frequencies for different taper angle.

Frequency (GHz)	Taper angle θ (degrees)	Radius of waveguide : a_{TE} (only TE ₁₁)	Radius of aperture : a_{TM} (TE ₁₁ + TM ₁₁)	Co-Polar Component (dB)	Cross Polar (dB)	Beam Symmetry (dB)
4.05	15	2.819	4.87	11.9	-21.2	38
4.35	13	3.27	4.71	12.69	-23.97	32
4.55	18	3.57	4.54	11.88	-32.08	104
4.80	15	3.00	4.27	12.505	-21.05	24
5.25	11	2.42	3.76	12.5	19.33	24
5.30	18	2.73	3.76	11.01	21.08	34
5.80	20	2.09	3.46	12.373	-19.6	40
5.90	18	2.11	3.50	12.84	-20.68	44
6.0	15	2.2	3.50	13.10	20.07	21
3.5	18	3.57	4.5	10.75	-30.15	168

Radiation in pattern in Rectangular plot showing cross polar and beam symmetry in below figures:

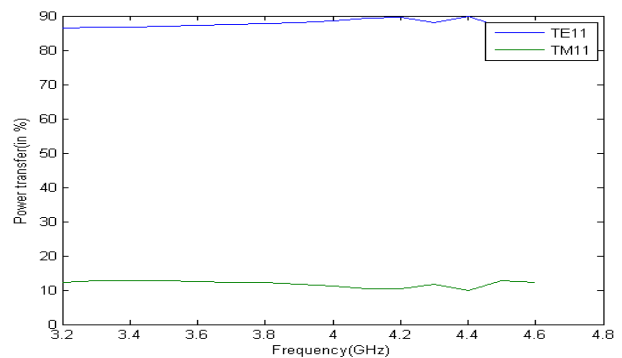

Figure : power gain

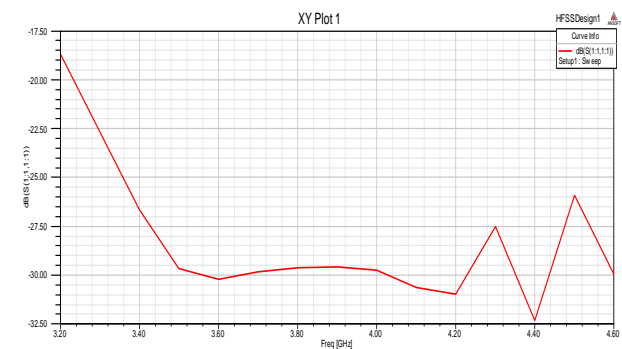

Figure: Return loss

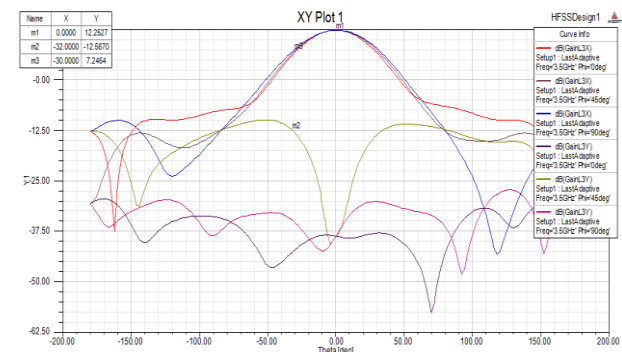

Figure: cross polarization

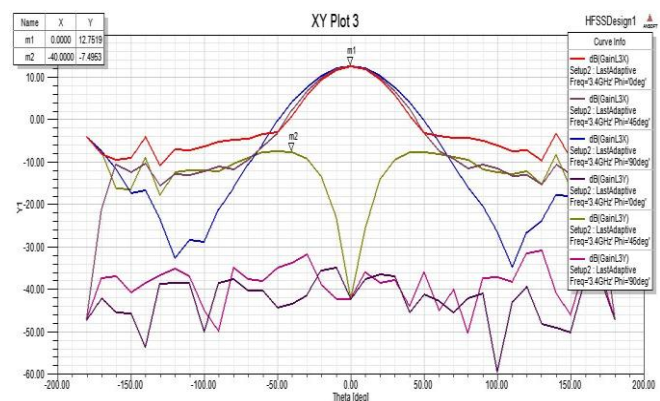

Figure: cross polarization

The design parameters of taper discontinuity for taper angle 30° have been discussed. The amount of powers in TE₁₁ and TM₁₁ mode over the frequency band are 86-89 % and 9-12 % respectively. The return loss better than 22 dB and 20 dB down cross polarization has been achieved over the frequency band of 1.4:1. In bandwidth 20% increment has been achieved as compare to step discontinuity. The design of taper discontinuity horn antenna divided into two taper angles of 15°, the bandwidth ratio is improved 1.66:1. Use this horn as feed for the front feed parabolic reflector antenna for F/D ratio is 0.6

APPLICATIONS

Circular horn with smooth walled conical used as feeds in reflectors, testing methods & sensing applications.

Multimode horns are useful in Radar, Satellite application, mobile communication there low side lobe levels & Low cross polarization are important features taken into consideration & in radio astronomy.

CONCLUSIONS

Dual mode conical horn has been designed in HFSS showing low cross polarization component at C- band which makes that antenna suitable for satellite applications like frequency reuse. More work on finding the other parameters which makes this antenna more efficient. More the beam symmetry, low the cross polarization component is achieved.

ACKNOWLEDGMENT

I am very much thankful to my guide Prof. Usha Neelakantan, without help of her it would have been tough task to find useful books upon antenna and microwave. Also thankful to college for vast resource they provided.

References

[1] C. A. Balanis, *Antenna Theory: Analysis and Design*, 2nd Ed. (New York: John Wiley & Sons, 1996)

[2] S. Silver, *Microwave Antenna Theory and Design*, McGraw-Hill Book Company, Inc., New York, 1949.

[3] S. Ramo, J.R. Whinnery, T.V. Duzer: *Field and Waves in Communication Electronics*, 3rd Ed. (New York: John Wiley & Sons) p. 444-448.

[4] **User's guide High frequency structure simulator**

[5] <http://www.Microwaves101.Com/Encyclopedias/Waveguides>

[6] Jae Sik Kim, Ji Hwan Yoon, "Design of Modified Dual Mode Horn Antenna to Improve E/H-plane Radiation Pattern

Symmetry", IEEE antenna and propagation, pg. 547-550 2012

[7] Elliott R. Nagelberg, "Design of dual mode conical horn for communication antennas", Bell Telephone Laboratories, pg. 284-288, 1979.

[8] S.M. Tun and P.R. Foster, "Computer optimized wideband dual-mode horn", *Electronics Letter*, pg. 768-769, July 2002.

[9] Chandrakanta Kumar, M. Kumar, V. Senthil Kumar, V. V. Srinivasan, "Dual Mode Conical Horn with Dual Circular Polarizations for TT&C System of a Geostationary Spacecraft", 2012

[10] Lingzhen Zeng, Charles L. Benette, David T. Chuss, And Edward J. Wollack, "A Low Cross Polarization Smooth Walled Horn With Improved Bandwidth".

[11] D. M. Pozar, *Microwave Engineering*, 3rd Ed, John Wiley and Sons, Inc., London, 2004.

[12] S. Silver, *Microwave Antenna Theory and Design*, McGraw-Hill Book Company, Inc., New York, 1949.

[13] John Volakis, *Antenna Engineering Handbook*, 4th Ed, McGraw-Hill Education, 2007.

[14] P. D. Potter, "A New Horn Antenna with Suppressed Sidelobes and Equal Beamwidths", *Microwave Journal*, p. 71-78; June, 1963.

[15] R. H. Turrin, "Dual mode small aperture antennas", *IEEE Trans.*, 1967, AP-15

BIOGRAPHIES



Shweta K. Gohil
M.E. communication system engineering.
Lecturer in L.J. polytechnic Ahmedabad



Prof. Usha Neelakantan
Head of the department