

# BER ANALYSIS USING LOG-MAP DECODING ALGORITHM FOR TURBO CODES CHANNEL

Anil Kumar Dubey<sup>1</sup>, Ruchika Doda<sup>2</sup>

<sup>1</sup> Assistant Professor, Department of Electronics & Communication Engineering, HIT, Haryana, India

<sup>2</sup> Assistant Professor, Department of Electronics Engineering, MVSIT, Haryana, India

\*\*\*

**Abstract** - Turbo codes are a new class of forward error correcting codes that have proved to give a performance close to the channel capacity as proposed by C. Shannon. A turbo code encoder is formed by the parallel concatenation of two identical recursive convolutional encoders separated by an interleaver. The turbo code decoder utilizes two cascaded decoding blocks where each block in turn shares a priori information produced by the other. The decoding scheme has the benefit to work iteratively such that the overall performance can be improved. In this paper, a performance analysis of turbo codes is carried out. Log maximum a posteriori probability (Log-MAP) algorithm is used in the performance analysis. The effect of using different decoding schemes is studied on both punctured and unpunctured codes. Simulations are carried out with the help of MATLAB tools.

**Key Words:** Turbo Codes, Interleaver, Log-likelihood Ratio, Log-Maximum a Posteriori Probability Algorithm, etc...

## 1. Introduction

Wireless technologies are the veritable explosions in telecommunication industries. Once exclusively military, satellite and cellular technologies are now commercially driven by ever more demanding consumers, who are ready for seamless communication from their home to their car, to their office, or even for outdoor activities. Although the deployment of 3rd generation cellular systems has been slower than was first anticipated, researchers are already investigating 4th generation (4G) systems [10, 11]. These systems will transmit at much higher rates than the actual 2G systems, and even 3G systems, in an ever crowded frequency spectrum. Signals in wireless

communication environments are impaired by fading and multipath delay spread. This leads to a degradation of the overall performance of the systems. Hence, several avenues are available to mitigate these impairments and fulfill the increasing demands. With this increased demand comes a growing need to transmit information wirelessly, quickly and accurately. To address this need, communications engineer have combined technologies suitable for high rate transmission with forward error correction techniques. Turbo codes are a new class of forward error correcting codes that have proved to give a performance close to the channel capacity as proposed by C. Shannon [4].

## 2. Turbo Code Encoder

A turbo code is a parallel concatenation of two or more recursive systematic convolutional codes [1-3]. A generalized turbo encoder is shown in Fig.1

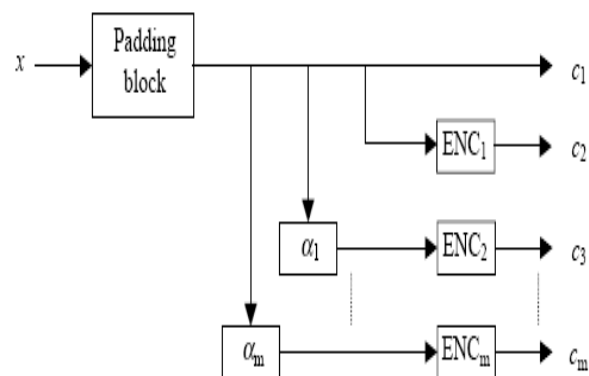

Fig. 1 turbo encoder

The input of the TC encoder is a data block  $x$ , with  $k$  information bits. To this information sequence the padding block appends  $v$  (memory size) tail bits, which then yield the sequence  $c1$ . This sequence of bits is then fed in parallel into  $m$  parallel sets of interleavers ( $\alpha_i$ ) and encoders [7]. The aim of the interleaver is to scramble the sequence  $c1$  before feeding the output of the padding block into other constituent encoders [5].

### 3. Turbo Code Decoder

Turbo codes offer the ability to build powerful codes that utilize a relative simple soft-decision decoding algorithm. This is possible because the turbo decoder is constructed from two identical serial decoding blocks that share information. The turbo code decoders often work iteratively (loop wise) by sharing a priori information obtained from the log-likelihood ratio (a posteriori information) of the previously cascaded decoder. The constituent decoders are the optimal decoders for the component codes used by the turbo encoder. Fig.2 gives a visual representation of the iterative and information sharing nature of the decoding strategy.

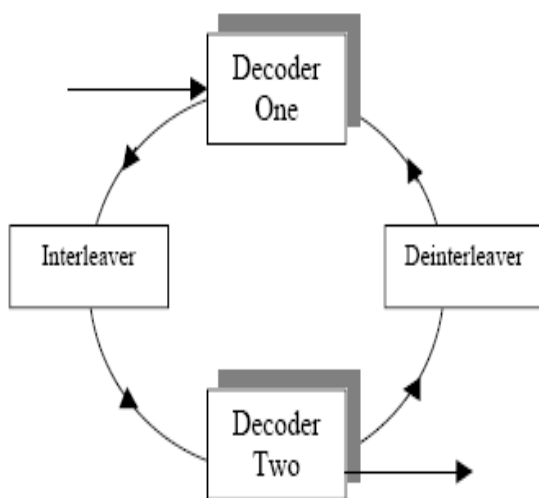

Fig.2 Turbo decoder

For turbo codes, the Soft Output Viterbi Algorithm (SOVA), and the Log-MAP decoding algorithm can be used as they produce soft-bit estimates. The Log-MAP decoding scheme is the modified version of the MAP decoding scheme and is computationally less complex than the original MAP decoding algorithm. However, due to the push for strikingly low bit error rates, the MAP or the Log-MAP has been most commonly used in turbo codes since they are based on the optimal decoding rule. In contrast, the SOVA is an approximation to the MAP sequence decoder and will have a slightly worse bit error performance. Though SOVA suffers from performance degradation as opposed to the Log-MAP decoding rules, it has much reduced complexity. So in this paper Log-MAP decoding algorithm is used for analysis.

### 4. Log-MAP Algorithm

To first understand the decoding of turbo codes, a preliminary understanding of the MAP algorithm is necessary. The idea was set out to estimate the posteriori probabilities of the states and transitions of a Markov sequence transmitted through a discrete memoryless channel. This work resulted in an algorithm that minimizes symbol error rates while trying to decode block and trellis codes. The aim of the MAP algorithm is to minimize the symbol error rate for the decoding of trellis and block codes. Therefore, after receiving the information through the channel, the job of the decoder is to determine the most likely input bits (original/uncoded information sequence), based on the received symbols. Since the input is over the binary alphabet, it is conventional to form a log-likelihood ratio (LLR) and base the bit estimates on comparisons based on magnitude of the likelihood ratio to a threshold. The log-

likelihood ratio for the input symbol indexed at time  $t$  is defined as

$$\Lambda(x_t) = \ln \frac{P(x_t = 1 | r)}{P(x_t = 0 | r)}$$

In this expression,  $P(x_t = i | r)$  is the a posteriori probability of the information bit,  $x_t \in \{0,1\}$ , when the knowledge of the received data  $r$  is given. The decoder produces estimates of the information bits based on the values of the log-likelihood ratio. The magnitude of the log-likelihood ratio is defined as the soft output or soft value which can be passed after processing to the other decoder as a priori information. The estimator obeys the following rule

$$x_t = \begin{cases} 1 & \text{if } \Lambda(x_t) \geq 0 \\ 0 & \text{otherwise} \end{cases}$$

The Log-MAP decoding algorithm is used which in fact is based on the same idea as the MAP decoding algorithm with the benefit that it simplifies the computation by eliminating the multiplicative operations and the need to store small values for the probabilities by including the logarithm operator in the computation [6,9]. The multiplicative operation is computationally more expensive than the addition operator in terms of processing speed of a microprocessor. Also the requirement of large amount of memory to store the probabilities in the computation of the log-likelihood ratio makes the implementation of this algorithm complex. After defining all the entities required in the decoding process the complete decoder structure for Log-MAP algorithm is shown in Fig. 3

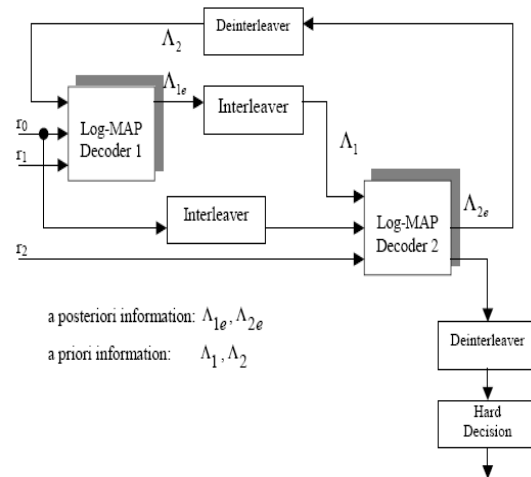

Fig. 3 Log-MAP algorithm

### 5. Simulation Results

The simulation results obtained by using Log-MAP decoding schemes for the additive white Gaussian noise channel are presented. The effect of puncturing is also studied by simulating the punctured scheme by using odd-even interleaving. The results for both punctured and unpunctured codes are obtained by simulating the schemes under identical parameters so that a fair comparison can be made [8].

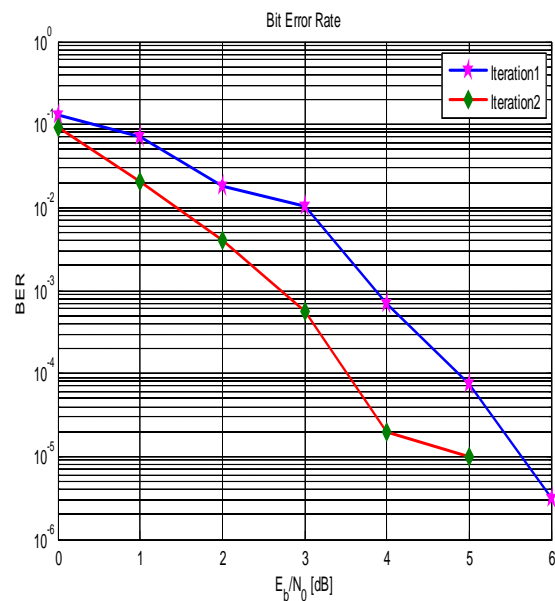

Fig 4 BER plot for log-map decoder: Punctured

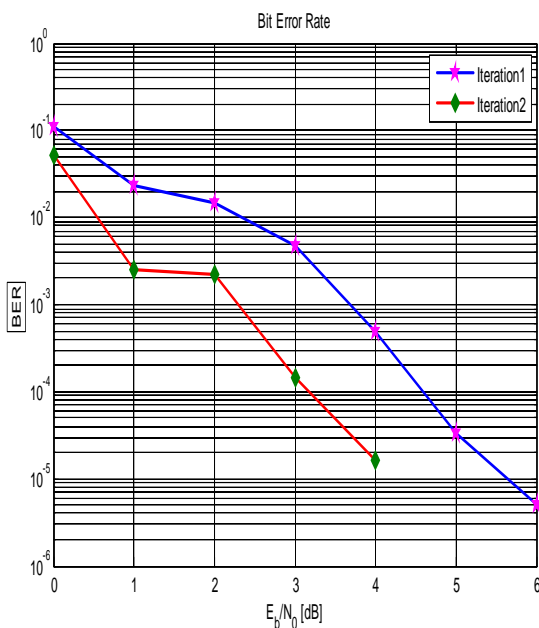

Fig 5 BER plot for log-map decoder:  
Unpunctured

From Fig 4 and Fig 5 it is clear that for log Map decoder punctured code degrades the performance of the decoder as compared to unpunctured code. From the simulation results we observed that an increase in code rate (punctured case) degrades the performance of the decoder as compared to unpunctured.

## 6. CONCLUSIONS

Turbo code, a very powerful error correcting coding scheme, which is formed by the parallel concatenation of two recursive non-systematic convolutional codes, is presented. From the simulation results we observed that an increase in code rate (punctured case) degrades the performance of the decoder as compared to unpunctured code. The simulation results clearly depicts that the code has the capability of reaching very low bit error rates at even small signal to noise ratios with increasing iterations. The objective of the iterative process is to further reduce bit errors. However, the evaluation of the number of iterations necessary

for optimal results has proven to be a difficult task. Log-MAP algorithm despite its superior performance is prone to memory overflows.

## ACKNOWLEDGEMENT

The authors can acknowledge any person/authorities in this section. This is not mandatory.

## REFERENCES

- [1] Joshi A. , Saini D.S. , "Performance analysis of coded-OFDM with RS-CC and Turbo codes in various fading environment" , Information Technology and Multimedia (ICIM), 2011 International Conference on, 14-16 Nov. 2011.
- [2] Qazi S.A. , Kahkashan S. , "A comparative analysis of power and device utilization of LDPC and Turbo encoders" , Information and Communication Technologies (ICICT), 2011 International Conference on, 23-24 July 2011.
- [3] Adnan T. , Masood A. , "Use of convolution coding for improving SER performance of OFDM system" , Communication Software and Networks (ICCSN), 2011 IEEE 3rd International Conference on 27-29 May 2011.
- [4] Zhang Xinyu , "A basic research on Forward Error Correction", Communication Software and Networks (ICCSN), 2011 IEEE 3rd International Conference on, 27-29 May 2011.
- [5] Soni S.K. , Chauhan P.S. ; Vasudevan, K. ; Shanker, Y. , "Turbo decoding in ISI channels" Emerging Trends in Networks and Computer Communications (ETNCC), 2011 International Conference on, 22-24 April 2011.
- [6] Abhishek Kumar S., Chakrabarti S. , " Performance Evaluation of Asymmetric Turbo Codes Using Log-MAP Decoding Technique " , Devices and Communications (ICDeCom), 2011 International Conference, Page 1 – 5, 24-25 Feb. 2011.
- [7] Saul L.-S.; Francisco G.-L., "A comparative study for turbo code interleavers designed for short frame size and relatively high SNR channel", 5<sup>th</sup> international IEEE Conference, 2011.

[8] Jiaxiang Li; Qingchun Chen; Suyue Gao; Zheng Ma; Pingzhi Fan, “*The optimal puncturing pattern design for rate-compatible punctured Turbo codes*”, international IEEE Conference , 2009.

[9] Jinhong Wu; Vojcic B.R., “*Combining iterative SOVA and Log-MAP algorithms for turbo decoding*”, Information Sciences and Systems, 43<sup>rd</sup> IEEE Conference,2009..

[10] Theodore S. Rappaport, “*Wireless Communications*”, Prentice Hall, 2002.

[11] J. G. Proakis, “*Digital Communications*”, McGraw Hill, 2002