

# Static Analysis of Motor Flange

Bhale Pritish P<sup>1</sup>, Lavnis Avinash K<sup>2</sup>

<sup>1</sup> PG Student, Bramhadevdada Mane Institute of Technology, Solapur, Maharashtra, India.

<sup>2</sup> Professor, Bramhadevdada Mane Institute of Technology, Solapur, Maharashtra, India.

\*\*\*

**Abstract** - This paper is about static analysis of flange of flange mounted motor which is also known as B5 type motor by using FEA software ANSYS 15 and modeling is done with help of CATIA V5 R20. This is the special problem which is observed by Laxmi Hydraulics Pvt. Ltd Solapur, Maharashtra, India. They have reported frequent failures of this type of flange.

**Key Words:** ANSYS R15, B5 Motor Flange, CATIA V5 R20, Static analysis.

## 1. INTRODUCTION

In industry there are various requirement of motion for which we are using prime movers like Motor or Engines. Motors are widely used as prime movers as it gives uniform motion and control of speed and direction is easy as compared to engines. There are few types of motors which are classified on basis of mounting methods. These are as follows:

- Types of motor
- B3- Foot mounting motor
- B 5- Flange mounting
- B 14-face mounting
- B 34-Foot cum face mounting
- B 35-foot cum flange mounting

B5 type is a motor in which flange is bolted to wall on which whole motor is mounted. So that entire weight of a motor is going to act on flange. This is the case which is somewhat similar with cantilever beam. This type of motor is used at elevation places like overhead cranes, overhead machines etc. the R & D department of Laxmi Hydraulics departments has given the dimensions of flange of B5 motor.



**Figure 1:** Flange of B5 type motor

## 2. FEA ANALYSIS OF B5 MOTOR FLANGE

Analysis can be defined as the process of breaking a complex topic into finite i.e. smaller parts for better understanding of it. The technique has been applied in the study of mathematics and logic since before Aristotle (384–322 B.C.), though analysis as a formal concept is a relatively recent development.

Basically in mechanical engineering the word analysis which comprises two phases out of which one is modeling and another is analysis. in this paper the analysis is carried out with help of ANSYS 15 and Modeling is done with CATIA V5 R20.

### 2.1 MODELING OF B5 FLANGE

Actual dimensions obtained by the firm are as follows:

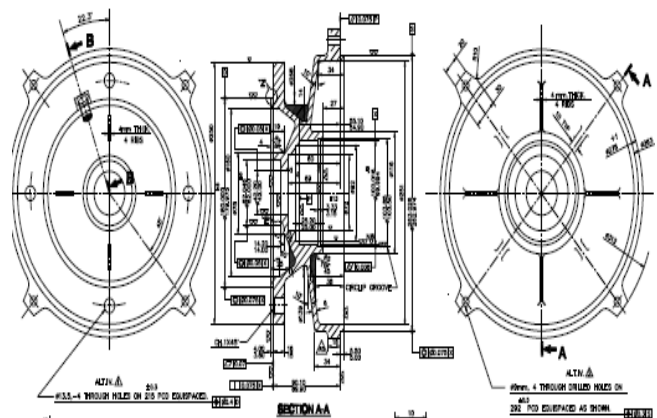

**Figure 2:** Actual dimensions of flange of B5 type motor

The modeling is done with CATIA V5 R20. All the dimensions are taken as per given by the firm.

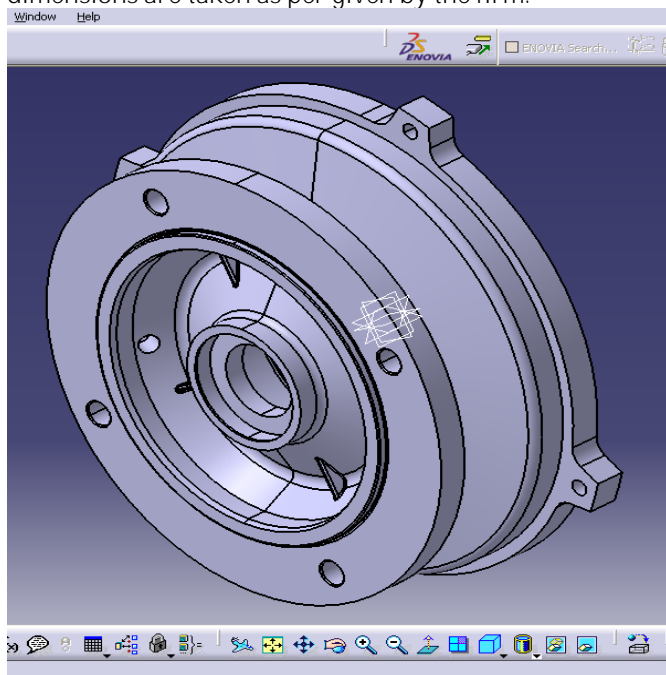

Figure 3: CATIA model flange of B5 type motor

For analysis though the analysis tool is available in CATIA but ANSYS software gives more accurate and correct prediction about the failure of flange. The first phase is modeling the joint using CAD software.

The model geometry was generated using CATIA software and then imported as a neutral file in ANSYS

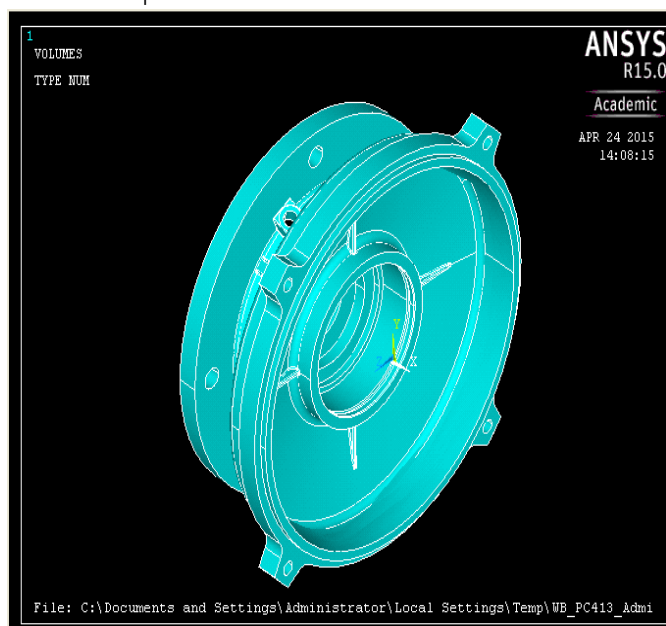

Figure 4: CATIA model flange of B5 imported in ANSYS

## 2.2 FEA MODEL

Next, the prepared geometric structure is reproduced by finite elements. The finite elements are connected by nodes that make up the complete finite element mesh.

Each element type contains information on its degree of freedom set (e.g. translational, rotational, and thermal), its material properties and its spatial orientation 3D-element type's solid brick 8 node. The mesh was controlled in order to obtain a fine and good quality mapped mesh. The flange had 21046 nodes.

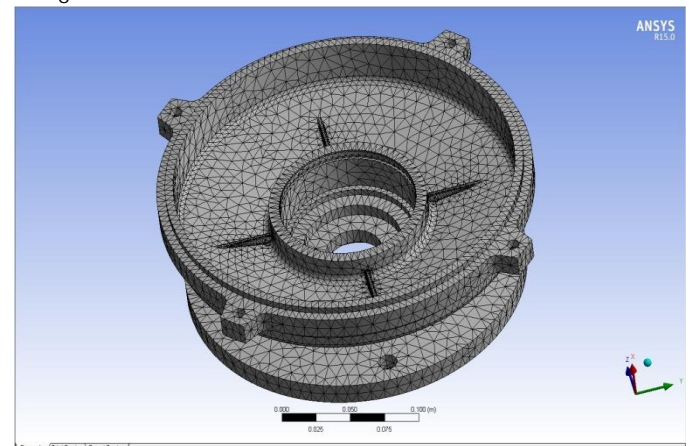

Figure 5: FEA Model

## 2.3 LOAD APPLICATION

In order to solve the resulting system equation, boundary and loaded conditions are specified to make the equation solvable. In our model, flange one end fixed and other end has different axial loads were applied. The same the boundary and loaded conditions is 4 bolt were applied. Load variation in range of 490 to 500 on bearing recess applied, with the downward axes along and flange length.

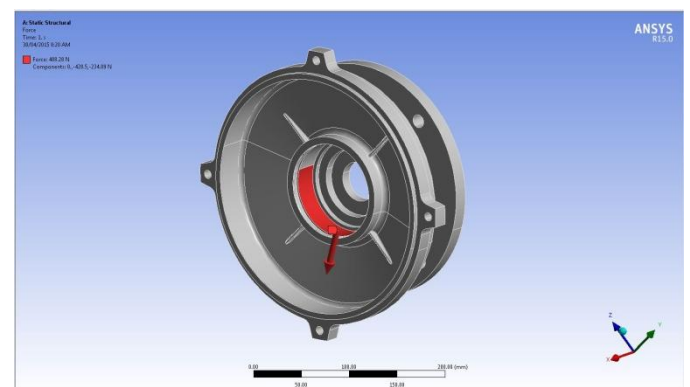

Figure 6: Load application

## 3. RESULTS

As analysis finishes, the result as shown in fig is found

### 3.1 STRESS ANALYSIS

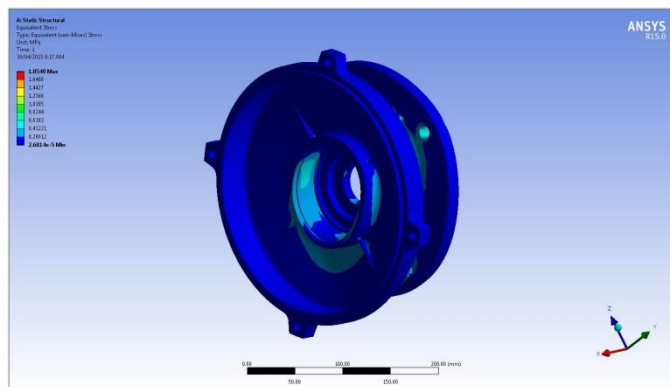

Figure 6: Stress distribution

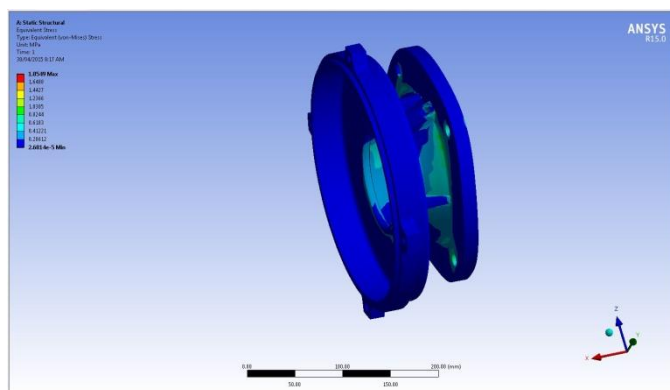

Figure 7: Stress distribution

Fig shows the stress distribution on the flange. It indicates that the range of the stress is 0.00023 to 1.23 Mpa. The maximum stresses are developed at the rib region around 1.20 Mpa.

### 3.2 DEFORMATIONS

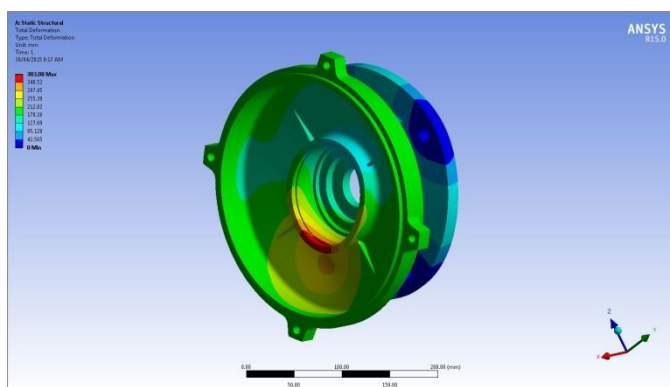

Figure 8: Deformation change.

Figure indicates the deformation of flange because of the load. The maximum deformation is occurs at the bottom of the bearings.

### 5. RESULTS

Table - 1: Results

Sr. No.	Material	Equivalent stress MPa	Total Deformation mm	Load Kg
01	C.I. (F.G. 200)	1.8549	0.383	48.5

### 6. CONCLUSION

The equivalent stresses for C.I. B5 motor flange are as shown in a Table 5. The Maximum equivalent stress for the same is 1.85 Mpa , which is safe for the given material by considering allowable strength (160 Mpa) of the C.I. by taking factor of safety into account.

The total deformations for the same 0.383 mm which is less as compared to existing material.

### REFERENCES

- [1] S.G. Chavan, *Stress analysis of flanged joint using FEM*, International journal of research and science, vol.3, Issue 8, Aug.2014.
- [2] V.G. Vijaya, *Analysis of rigid flange coupling*, International Journal of Innovative Research in Science, engineering & Technology, Vol.2, Issue 12, pp. 7118-7126, 2013.
- [3] S.N. Datey et. all , *Finite Element Analysis of Universal Joint*, IOSR journal of Mechanical and civil Engineering, Vol.2, Issue 3, pp. 64-69, 2010.
- [4] V.B. Bhandari, *Design of Machine Elements*, Tata Mc.Graw Hill companies, Second Edition, pp.323-389.
- [5] PSG Design data Book, pp. 01-42.