

PARAMETRIC STUDY OF CASTELLATED BEAM WITH CIRCULAR AND DIAMOND SHAPED OPENINGS

Jamadar A. M.¹, Kumbhar P. D.²

¹ PG Scholar, Department of Civil engineering, RIT Islampur, Maharashtra, India

² Associate Professor, Department of Civil engineering, RIT Islampur, Maharashtra, India

Abstract - Use of castellated beams is become very popular now a days due to its advantageous structural applications. Castellated beams are those beams which has openings in its web portion. Castellated beams are fabricated by cutting the web of hot rolled steel (HRS) I section into zigzag pattern and thereafter rejoining it over one another. The openings made in the webs are of generally hexagonal, circular, diamond or square in shape. Therefore, considering structural performance of the beam, the size and shape of openings provided in the web are always an important issue of concern. There is lot of study has been done in optimizing sizes of castellated beams with hexagonal openings, and hence there is need to optimize the beams with other shaped openings. While the local failure associated with the castellated beam can be minimized by providing other shaped openings like circular, diamond shapes etc. Therefore in this paper, parametric study of castellated beams with circular (cellular beam) and diamond shaped openings has been carried out to optimize its size by considering ratio of overall depth castellated beam to the depth of opening provided (D/Do) and the ratio of spacing of opening to the depth of opening (S/Do). The finite element analysis (FEA) of the beam using Abaqus/CAE 6.13 software and following the provisions of Eurocode 3 has been carried out for different sizes of openings. Von-misses failure criteria is used to finding out failure load on the beam and the results obtained for optimized beam is validated by experimentation. Results showed that, the beam gives better strength results for diamond shaped opening with opening size of 0.67 times overall depth of the beam. It is also observed that, castellated beams are mostly tend to fail in their local modes of failure.

Key Words: Castellated beam, Circular web opening, Diamond web opening, Cellular beam, Finite Element Analysis, Abaqus/CAE 6.13, Optimization etc.

1. INTRODUCTION

Use of steel for structural purpose in structure is rapidly gaining interest these days. In steel structures the concept of pre-engineered building (PEB) is most popular due to its ease and simplicity in the construction. Pre-engineered

buildings have very large spans but comparatively less loading. Generally, steel sections satisfy strength requirement, the difficulty is that, section have to satisfy serviceability requirement i.e. deflection criteria in safety check. This necessitates the use of beams with greater depth to satisfy this requirement. Use of castellated beams is the best solution to overcome this difficulty. The castellated or perforated web beam is the beam which has perforation or openings in its web portion. Generally, the openings are with hexagonal or square or circular in shapes. The beams with circular openings are called as cellular beams. The advantage of using such beams is that it causes reduction in total weight of the structure and hence requires less quantity of steel.

Use of castellated beam with hexagonal opening is very common in recent years because of the simplicity in its fabrication. Castellated beams are fabricated by cutting flange of a hot rolled steel I beam along its centerline and then welding the two halves so that the overall beam depth gets increased for more efficient structural performance against bending.

1.1 Types of Castellated Beam

Castellated beams are generally classified on the basis of type or shape of perforation made in the web of the beam. These classifications are as follows;

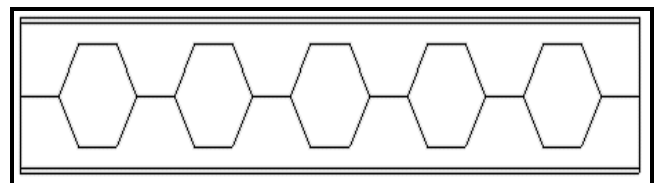

Fig -1: Hexagonal Castellated Beam

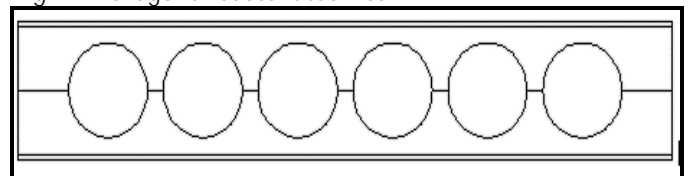

Fig -2: Cellular Beam

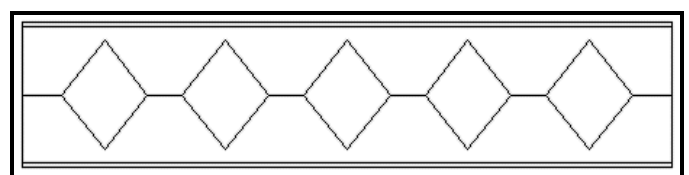

Fig -3: Castellated Beam with Diamond Shaped Opening

2. REVIEW OF PREVIOUS STUDIES

In recent times, a lot of research work has been carried out for analysis and design of castellated beams, especially with hexagonal openings. There is no universally accepted design method for castellated beam because of complexity in geometry accompanied by complex mode of failure. At present, there are possibly six failure modes of castellated beam namely, formation of flexure mechanism, lateral torsional buckling, formation of Vierendeel mechanism, rupture of welded joint, shear buckling of web post and compression buckling of web post. Various research studies carried out for analysis and design of castellated beams are presented in the following section.

2.1 Wakchaure and Sagade [13]

Authors have studied the flexural behavior of steel I-shaped castellated beams with hexagonal openings. The beams were modelled for different depths of web openings by varying spacing to depth ratio (i.e. s/d). The analysis of the castellated steel beams (I-shaped cross-section), is done using finite element software package ANSYS14 with two point load and simply supported support condition. The deflection at center of beam and study of various failure patterns are studied. The beams with increase in depth are then compared with each other and with parent section for various parameters and for serviceability criteria. From the results, it is concluded that, the Castellated steel beam behaves satisfactorily with regards to serviceability requirements up to a maximum web opening depth of 0.6 times the overall depth. Castellated beams have proved to be efficient for moderately loaded longer spans where the design is controlled by deflection.

2.2 Wakchaure, Sagade and Auti [12]

The authors have experimentally studied the behavior of castellated beams under two point loading (four point bending) by varying the depth of hexagonal openings (and hence the overall depth). The results indicate that beam with opening size of 0.6 times the overall depth carries maximum load compared to other sizes of openings. Also, authors have concluded that with increase in depth of opening, Vierendeel failure of beam becomes predominant.

2.3 Soltani, Bouchair and Mimoune [10]

The authors have prepared a nonlinear numerical model to obtain behavior of castellated beams with hexagonal and octagonal openings. Parametric study is also carried out by varying depth of openings with increments of 10mm. The numerical results are compared with the existing literature and validated with help of MSC/NASTRAN software. The failure patterns of beams with various sizes are also studied.

2.4 F. Erdal and M. P. Saka [05]

Studied the load carrying capacity of optimally designed castellated beam with various number of holes and spacing. Finite element analysis of same beams is also carried out under the application of centrally applied point

load and failure patterns are studied and verified using ANSYS. Study shows that, even though the members are relatively of shorter spans, lateral supports are governing factor for the analysis of beams due to torsional buckling. It is concluded that, the beam fails in Vierendeel mode when the load is applied above the openings while it fails in web post buckling when load is applied in between space of the openings.

3. ANALYSIS AND DESIGN OF CASTELLATED BEAM AS PER EUROCODE 3

3.1 Terminology in Castellated Beam

Before going to see the design standards for castellated beam it is important to understand the some of basic terminologies used in the design of castellated beam, these terms are illustrated in the following Fig -4.

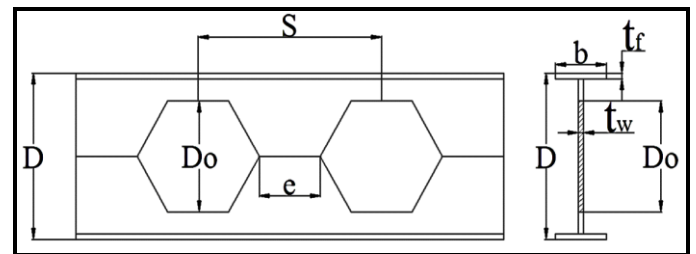

Fig -4: Typical cross section of the beam

Where,

- Do = Depth of opening provided.
- D = Overall depth of the opening.
- S = C/C spacing between the two opening
- e = Clear distance between two opening
- b = Width of flange of I beam
- tf = Thickness of flange of I beam
- tw = Thickness of web of I beam

3.2 Guidelines for Perforations in Web

The perforations made in the web are greatly affecting the structural performance of the beam. Therefore, some logical and practical considerations need to be observed while providing perforations in the beam. Following are the general guidelines which are given by Eurocode and some of them are based on the field or practical considerations. These standards in web perforations can be changed or modified without affecting the structural performance of the beam. These guidelines are as follows;

1. $1.08 < \frac{S}{D_o} < 1.5$
2. $1.25 < \frac{D}{D_o} < 1.75$
3. $D_o \leq 0.8 D$
4. $e \leq 0.4 D_o$
5. **Width of end post $\geq 0.5 D_o$**

3.3 Design of Castellated Beam

In this section, design standards provided by Eurocode 3 for designing of castellated beam are illustrated.

3.3.1 Moment (flexural) capacity of the beam

In this check, we have to ensure that maximum moment induced in the beam due to external loads should be less than moment capacity of the upper and lower Tee.

$$M_u < M_{pTee}$$

$$M_{pTee} = A_{Tee} \times P_y \times z$$

Where,

M_u = Maximum moment induced in the beam as per loading conditions.

M_{pTee} = Moment capacity of the upper or lower Tee.

A_{Tee} = Area of upper or lower Tee.

P_y = Yield stress of steel.

z = Lever arm (Distance between the centroid of upper and lower Tee).

3.3.2 Shear capacity of the beam

Maximum vertical and horizontal shear induced in the beam due to external loading should be less than vertical and horizontal shear capacities of the beam respectively.

$$V_{Vmax} < P_v$$

$$P_v = 0.6 \times P_y \times A_v$$

$$V_{Vmax} < P_{vy}$$

$$P_{vy} = 0.6 \times 0.9 \times A_{wt}$$

$$V_{Hmax} < P_{vh}$$

$$P_{vh} = 0.6 \times P_y \times A_{mwt}$$

$$V_H = T_{i+1} - T_i$$

$$T = \frac{M}{z}$$

Where,

V_{max} = Maximum vertical shear.

H_{max} = Maximum horizontal shear.

P_v = Shear strength of castellated beam.

A_v = Shear area (shear area of whole cross section)
 $= (D - 2t_f) \times t_w$

P_{vy} = Vertical shear capacity.

A_{wt} = Shear area of Tee = $(D - 2t_f - D_o) \times t_w$.

P_{vh} = Horizontal shear capacity.

A_{mwt} = Horizontal shear area = $e \times t_w$

V_H = Horizontal shear.

T = Axial load at different point.

M = Bending moment at different point.

3.2.3 Flexural and buckling strength of web post

Flexural and buckling strength of web post should be checked by the empirical formula given below,

$$\frac{M_{max}}{M_e} < \left[C1 \left(\frac{S}{D_o} \right) - C2 \left(\frac{S}{D_o} \right)^2 - C3 \right]$$

Where,

M_{max} = Bending moment of critical web post section
 $= V_{hmax} \times \left(\frac{D_o}{2} \right)$

M_e = Bending resistance of critical web post section
 $= \frac{t_w \times P_y \times (S - 2b)^2}{2}$

$$C1 = 5.097 + 0.1464 \left(\frac{D_o}{t} \right) - 0.00174 \left(\frac{D_o}{t} \right)^2$$

$$C2 = 1.441 + 0.0625 \left(\frac{D_o}{t} \right) - 0.000683 \left(\frac{D_o}{t} \right)^2$$

$$C3 = 3.645 + 0.0853 \left(\frac{D_o}{t} \right) - 0.00108 \left(\frac{D_o}{t} \right)^2$$

3.2.4 Vierendeel bending of Tee

Vierendeel bending moment of the lower or upper Tee should be less than the local bending resistance of respective Tee.

$$M_{pTeeLocal} = \frac{A_{Tee} \times P_y \times Z_{Tee}}{2}$$

$$M_{pv} = V_{max} \times l_{eff}$$

Where,

$M_{pTeeLocal}$ = Bending resistance of Tee of beam.

M_{pv} = Vierendeel bending moment.

l_{eff} = Effective length of opening.

Effective length of opening is depends on the type of opening provided.

For Circular opening, $l_{eff} = 0.45 \times D_o$

For other opening l_{eff} is width of opening.

3.2.5 Fracture in welding

Strength of weld should be more than maximum horizontal shear force in the section,

$$\text{Shear strength of the weld} > V_{hmax}$$

$$\text{Shear strength of the weld} = \frac{e \times t_w \times P_y}{\sqrt{3}}$$

3.2.6 Deflection Check

Deflection of beam is calculated as per standard formulae for perforated depth of the beam. Additional deflection due to openings is calculated by adding 15% to 25% deflection in above calculated deflection.

4. METHODOLOGY ADOPTED IN FOR OPTIMIZATION OF OPENINGS

Following the design standards of Eurocode, the approach is decided to achieve objectives of the research. The analysis of the beam with circular and diamond shaped openings is carried out for different sizes and the optimized section is tested experimentally for the purpose of validation of the research.

4.1 Selection of Method of Analysis

In order to optimize the dimension of the openings of the castellated beam, it is very important to decide proper analytical method. Due to complex geometry of castellated beam the finite element analysis (FEA) is the best available method to analyze the beams. The FEA of the castellated beam under consideration is done by the simulation software namely Abaqus/CAE 6.13.

4.2 Selection of Section for Parent Hot Rolled Steel (HRS) I Beam and Span of the Beam

Span of the parent HRS I beam was decided taking into account the testing facilities available with the Universal Testing Machine (UTM) in the laboratory and also on the basis of availability of the section in the market. The parent HRS I beam section of 100mm depth was chosen due to the limitations on span (900mm) and maximum loading capacity (600kN) of UTM. The cross section of the beam is as shown in Fig -5

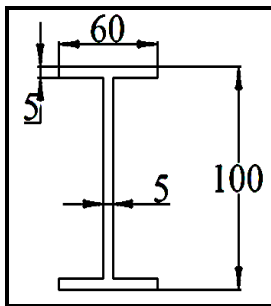

Fig -5: Cross section of the parent I beam (in mm)

4.3 Selection of Parameters for Parametric Study on Beam with Circular and Diamond Shaped Openings

Depending upon the limitations of opening specified by the codes, different dimension of the circular openings are selected. The parameter considered for the study is D/Do ratios and S/Do of the opening. The variations in the parameters and corresponding cross sectional dimensions of the circular openings are given in Table -1. All the castellated beams have been derived from the 100 mm depth HRS I section. The analysis of all the beams considering the parameters given in Table -1 are modelled and analyzed in Abaqus software and the optimized section is found out.

While varying the S/Do ratio for cellular beam, it can be observed that, as we goes on reducing S/Do ratio (from 1.4 to 1.2) the clear distance between two opening (i.e. 'e') reduces. So beam is tend to fail in local failure of horizontal shear. Therefore, in parametric study of square and diamond shaped openings only beams with S/Do equals to 1.4 are taken in considerations while varying the D/Do ratio from 1.25 to 1.75. These parameters are given in Table No. 2 for diamond shaped openings.

4.3 Failure Criteria

In order to decide the failure of the beam in Abaqus, Von-misses failure criteria has been used. The criteria states that, failure of the structure would take place if the von-misses stresses in the structure reaches to the value of yield stress of the material. Thus, in the present work, as the material used is steel, the load has been worked out corresponding to the yield stress of 250 N/mm².

Table -1: Parameters considered for circular shaped opening

Sr. No.	Do (mm)	D (mm)	D/Do	S/Do	S (mm)	e (mm)
1	120	155	1.29	1.4	168	48
2	110	150	1.36	1.4	154	44
3	100	145	1.45	1.4	140	40
4	90	140	1.56	1.4	126	36
5	80	135	1.69	1.4	112	32

6	120	155	1.29	1.3	156	36
7	110	150	1.36	1.3	143	33
8	100	145	1.45	1.3	130	30
9	90	140	1.56	1.3	117	27
10	80	135	1.69	1.3	104	24
11	120	155	1.29	1.2	144	24
12	110	150	1.36	1.2	132	22
13	100	145	1.45	1.2	120	20
14	90	140	1.56	1.2	108	18
15	80	135	1.69	1.2	96	16

Table -2: Parameters considered for diamond shaped opening

Sr. No.	Do (mm)	D (mm)	D/Do	S/Do	S (mm)	e (mm)
1	130	165	1.27	1.4	182	52
2	120	160	1.33	1.4	168	48
3	110	155	1.41	1.4	154	44
4	100	150	1.50	1.4	140	40
5	90	145	1.61	1.4	126	36
6	80	140	1.75	1.4	112	32

5. FINITE ELEMENT ANALYSIS OF CASTELLATED BEAM WITH CIRCULAR OPENINGS

FEA of all castellated beams is carried out in Abaqus software to determine the optimum section which fails at greater load. FE model of one of such cellular beams is shown in Fig -6 along with loading and boundary condition. The beam is modelled as 3D shell element and the meshing of model is shown in Fig -7. Quad-dominated S4R doubly curved element is used for meshing purpose. The various dimensions of openings along with their loads at yielding, deflections by FEA and their respective stresses for yield load are given in Table -3 for circular shaped openings.

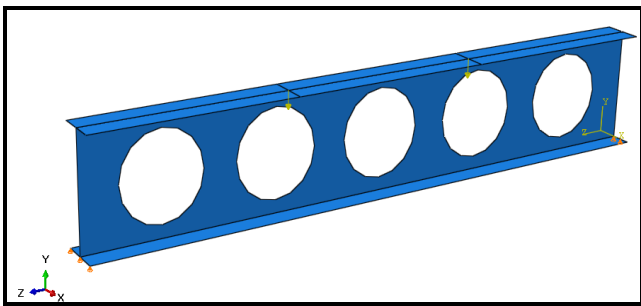

Fig -6: FE model of castellated beam in Abaqus

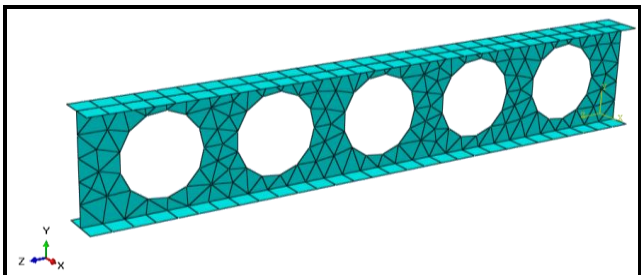

Fig -7: Meshing of castellated beam in Abaqus

4	90	140	29	1.42	250.104
5	80	135	25	1.12	256.941
6	120	155	30	2.001	253.875
7	110	150	31	1.65	265.547
8	100	145	29	1.65	250.875
9	90	140	28	1.59	254.768
10	80	135	26	1.41	250.97
11	120	155	28	2.19	251.289
12	110	150	31	1.5	249.92
13	100	145	28	1.72	248.901
14	90	140	27	1.66	240.37
15	80	135	25	1.66	257.452

From the result of this analysis it is observed that the beam with depth of opening 0.7 times its overall depth behaves satisfactorily in respect of load carrying capacity (32.5 kN). In the other words beam with D/Do ratio of 1.36 and S/Do ratio of 1.4 gives more satisfying results than the other. The variation in failure load against the depth of opening is illustrated in graphical format in Chart -1. While Fig -8 and Fig -9 shows the variation in stress (maximum 255.019 N/mm²) and deflection (maximum 1.858 mm) respectively for optimized castellated beam with circular opening.

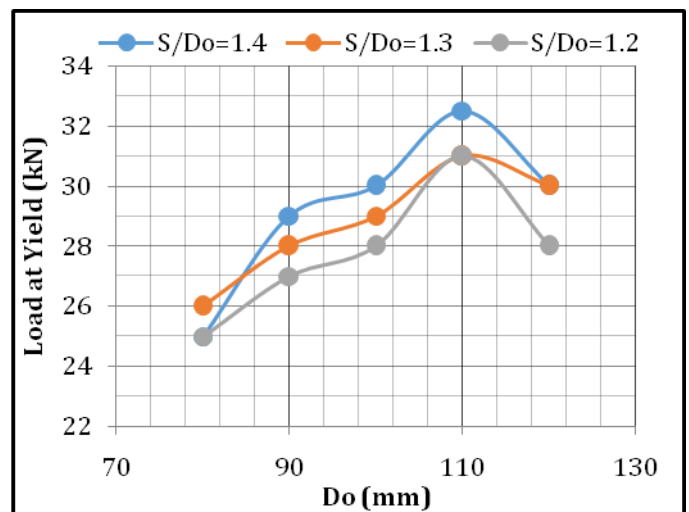

Chart -1: Variation in yield load for different S/Do and D/Do ratio for cellular beam

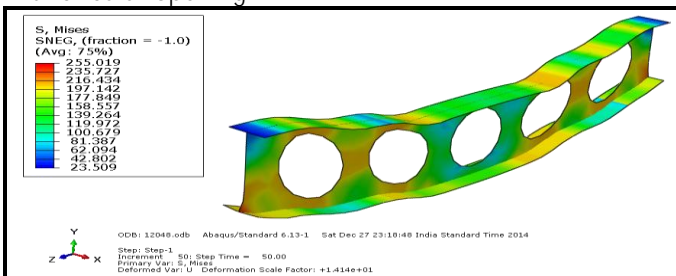

Fig -8: Variation in stresses of optimized cellular beam

Table -3: Results of FEA of castellated beam with circular openings

Sr. No.	Do (mm)	D (mm)	Load at Yield (kN)	Deflection by FEA (mm)	Stresses (N/mm ²)
1	120	155	30	1.75	253.928
2	110	150	32.5	1.85	255.019
3	100	145	30	1.84	248.293

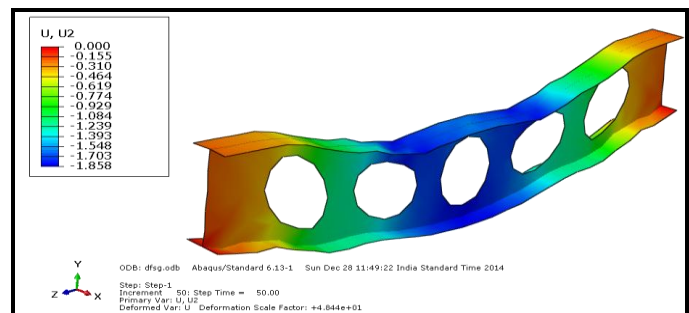

Fig -9: Deflection of optimized cellular beam

6.FINITE ELEMENT ANALYSIS OF CASTELLATED BEAM WITH DIAMOND OPENINGS

Finite element analysis of beams with diamond shaped openings is also carried in the same manner described earlier. Same boundary conditions, loading and meshing is applied on all types of beam mentioned in Table -2 and results are obtained. Table -4 gives the yield load and respective stresses and deflection of diamond shaped openings.

Table -4: Results of FEA of castellated beam with diamond openings

Sr. No.	Do (mm)	D (mm)	Load at Yield (kN)	Deflection by FEA (mm)	Stresses (N/mm ²)
1	130	165	30	1.94	255.209
2	120	160	31	2.27	249.974
3	110	155	32.5	2.315	248.357
4	100	150	34	2.48	254.165
5	90	145	33	2.338	251.762
6	80	140	31	1.148	252.463

From the result of above analysis it is observed that the beam with depth of opening 0.6 times its overall depth behaves satisfactorily in respect of load carrying capacity (34 kN). In the other words beam with D/Do ratio of 1.5 and S/Do ratio of 1.4 gives more satisfying results than the other. The variation in failure load against the depth of opening is illustrated in graphical format in Chart -2. While Fig -10 and Fig -11 shows the variation in stress (maximum 254.165 N/mm²) and deflection (maximum 2.48 mm) respectively for optimized castellated beam with diamond opening.

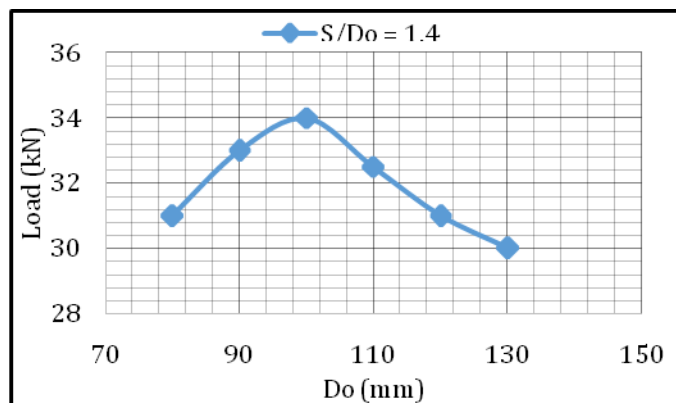

Chart -2: Variation in yield load for different S/Do and D/Do ratio for diamond openings

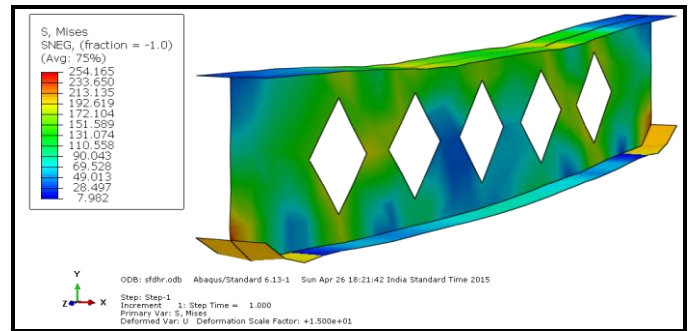

Fig -10: Variation in stresses of optimized diamond openings

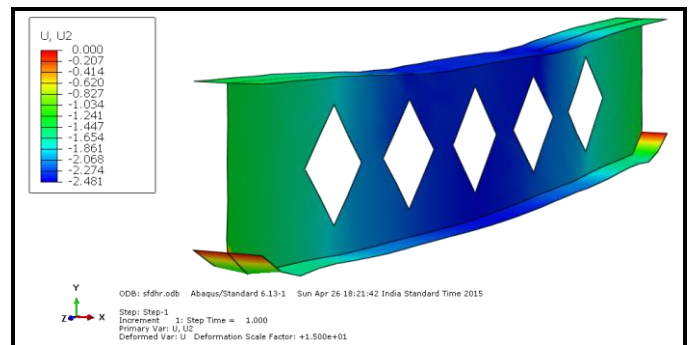

Fig -11: Deflection of optimized diamond openings

7.EXPERIMENTAL VALIDATION OF OPTIMIZED CASTELLATED BEAM

Optimized beam which are obtained by finite element analysis are fabricated and tested in the laboratory under the two point loading applied by universal testing machine (UTM) of capacity 600 kN. The test setup for both the optimized beam with circular and diamond shapes are shown in Fig -12 and Fig -13 respectively. Deflection is measured at center by using dial gauge. The results of these tests are given in Chart -3 and Chart -4 for circular and diamond shaped openings respectively in graphical form by load vs. deflection curve.



Fig -12: Test set up of circular castellated beam

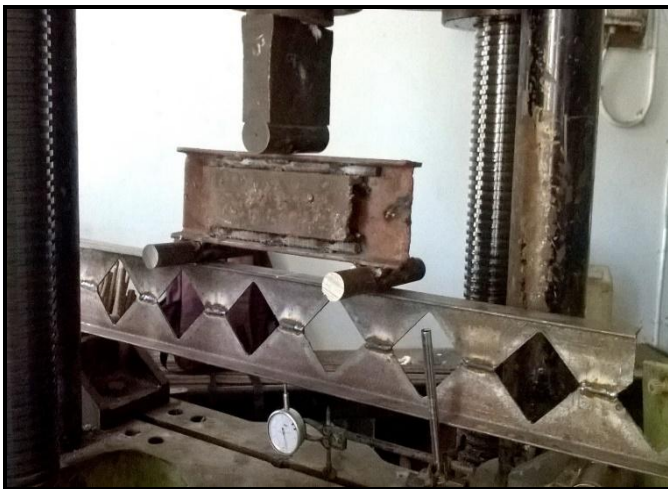

Fig -13: Test set up of circular castellated beam

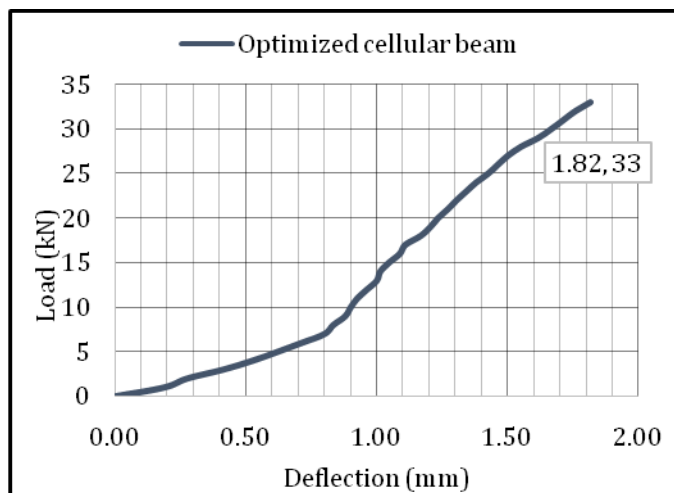

Chart -3: Load vs. Deflection curve for castellated beam with circular openings

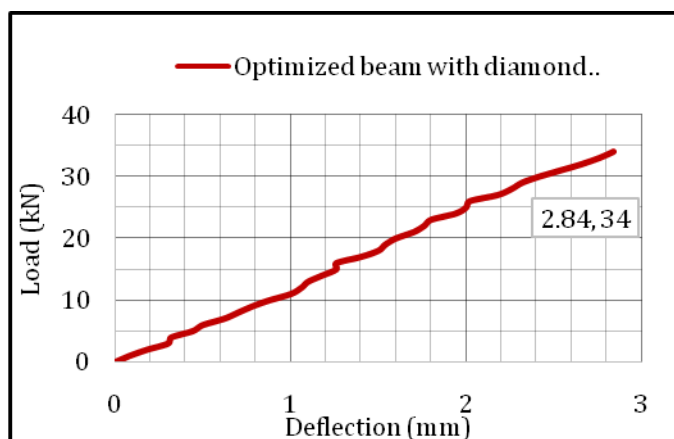

Chart -4: Load vs. Deflection curve for castellated beam with diamond openings

From above graphs, it is observed that optimized beam with circular opening takes the load of 33 kN causing the deflection of 1.82 mm and optimized beam with diamond

shaped opening takes the load of 34 kN causing deflection of 2.84 mm. Therefore, from this analysis it is concluded that castellated beam with diamond shaped openings behaves satisfactorily in on account of strength requirement.

8. COMPARATIVE STUDY OF CASTELLATED BEAM WITH CIRCULAR AND DIAMOND SHAPED OPENING

After finding out optimized dimension for circular and diamond shaped castellated beam it is very important to choose the optimized shape for openings. In order to find out optimized shape comparison of results of both circular and diamond shaped openings need to be done. This comparison of results of castellated beam with hexagonal, circular and diamond shaped openings are given in Table - 5 below,

Table -5: Failure load and deflection of castellated beam along with their shape of openings

Sr. No.	Type of castellated beam (shape wise)	Failure load by von-mises criteria (kN)	Deflection by FEA (mm)	Deflection by experiment (mm)
1	Hexagonal Opening ^[13]	30	1.3	1.36
2	Circular opening	32.5	1.85	1.82
3	Diamond opening	34	2.48	2.84

From above Table -5 it is concluded that castellated beams with diamond shaped is more reliable in respect of strength requirement. In the other words, the castellated beam with diamond shaped opening with D/Do ratio of 1.5 and S/Do ratio of 1.4 gives more satisfying strength results than the other shapes and sizes of castellated beam.

9. CONCLUSIONS

1. Castellated beam with circular shaped openings (Cellular beam) with opening size of 0.73 times its overall depth with S/Do ratio of 1.4 and D/Do ratio of 1.41 of takes 32.5 kN load.
2. Castellated beam with diamond shaped openings with opening size of 0.67 times its overall depth with S/Do ratio of 1.4 and D/Do ratio of 1.5 of takes 34 kN load.
3. As in case of diamond shaped openings more shear transfer area is available so there is minimum effects of local failure. Therefore, castellated beam with diamond shaped openings proves to be better than the other shaped openings in respect of taking.
4. Results of Abaqus software (FEA) are in good agreement with the results of experimentation and also with method analysis given by codes.

REFERENCES

- [01] Boyer J. P., "Castellated beam – new developments", *AISC National Engineering Conference, AISC Engineering Journal*, Vol. 3, pp. 106-108, 1964.
- [02] British Standard Institution. (1992), "Design of steel structures. Part 1.1: General rules and rules for buildings", Eurocode 3, ENV 1993-1-1:1992.
- [03] British Standard Institution. (2000), "Structural use of steelwork in building. Part 1: code of practice for design rolled and welded sections", BS 5950-1:2000.
- [04] Durif S. and Bouchair A., "Behavior of cellular beams with sinusoidal openings", *Steel Structures and Bridges, Procedia Engineering*, Vol. 40, pp. 108-113, 2012.
- [05] Erdal F. and Saka M. P., "Ultimate load carrying capacity of optimally designed steel cellular beams", *Journal of Constructional Steel Research*, Vol. 80, pp. 355-368, 2013.
- [06] Khennane A., *Introduction to finite element analysis using MATLAB and Abaqus*, 1st Edition, CRC Press, New York, 2013.
- [07] Lawson R. M. and Hicks S. J., *Design of composite beams with large openings*, SCI P355, SCI Publication, Berkshire UK, 2011.
- [08] Pachpor P. D., Gupta L. M. and Deshpande N. V., "Analysis and design of cellular beam and its verification", *2013 International Conference on Applied Computing, Computer Science and Computer Engineering, IERI Procedia*, Vol. 7, pp. 120-127, 2014.
- [09] Raftoyiannis I. G. and Ioannidis G. I., "Deflection of castellated I beam under transverse loading", *Steel Structures*, Vol. 6, pp. 31-36, 2006.
- [10] Soltani M. R., Bouchair A. and Mimoune M., "Nonlinear FE analysis of the ultimate behavior of steel castellated beams", *Journal of Constructional Steel Research*, Vol. 70, No. 2012, pp. 101-114, 2011.
- [11] Redwood R. and Demirdjian S., "Castellated beam web buckling in shear", *ASCE Journal of Structural Engineering*, Vol. 124, pp. 1202-1207, 1998.
- [12] Wakchaure M.R., Sagade A.V. and Auti V. A., "Parametric study of castellated beam with varying depth of web opening", *International Journal of Scientific and Research Publication*, Vol. 2, No.8, pp. 2153-2160, 2012.
- [13] Wakchaure M.R. and Sagade A.V., "Finite element analysis of castellated steel beam", *International Journal of Engineering and Innovative Technology*, Vol.2, No. 1, pp. 3744-3755, 2012.
- [14] Zirakian T. and Showkati H., "Distortional buckling of castellated beams", *Journal of Constructional Steel Research*, Vol. 62, pp. 863-871, 2006.

BIOGRAPHIES



Jamadar A. M., P.G. (Civil Structures) Scholar, Department of Civil Engineering, RIT Islampur, Sangli, Maharashtra, India.

Email:
athar.jamadar@gmail.com



Kumbhar P. D., Associate Professor, Department of Civil Engineering, RIT Islampur, Sangli, Maharashtra, India.

Email:
popat.kumbhar@ritindia.edu