

Design and Development of ON-LINE UPS using PIC Microcontroller

¹ Hemal Patel, ² Divyesh Vaghela

¹ Hemal Patel, M.Tech Student, Institute of technology, Nirma University, Ahmedabad, India.

² Divyesh Vaghela, Assistant Professor, Institute of Technology, Nirma University Ahmedabad, India.

Abstract: The proposed ON-Line uninterruptible power supply (UPS) offers AC voltage regulation on continuity basis which incorporates with the controllable battery charger. The battery used is Lead Acid Type battery. The charge control technique used for battery is constant current charging technique. The Constant Current is achieved by limiting the duty cycle of charger (or step-down chopper). In proposed scheme, protection of battery over charge and battery under discharge is available with relay trip through PIC 16F877A microcontroller by monitoring voltages on continues basis. The backup of battery takes place the load without spikes or delay when the mains power gets fails or interrupted. Based upon the proposed constant current charging technique, a digital charger is designed and is control through PIC 16F877A microcontroller software. The inverter used is simple square wave inverter. Experimental results using PIC 16F877A microcontroller controlled battery charger cum rectifier is presented to shows the effectiveness of the proposed design.

Key Words: UPS - Uninterruptible Power Supply, PIC - Peripheral Interface Controller, LCD - Liquid Crystal Display

1. Introduction:

An uninterruptible power supply (UPS) is a power conditioner that provides emergency power to a load when the mains power fails. In on-line UPS, the load is always connected to the inverter though the UPS static switch. When the AC main is available, the rectifier circuit will supply the power to the inverter as well as to the battery and battery will be charged. If the supply power fails suddenly, the battery will supply power to the inverter without any interruption and delay. If the UPS fails (inverter fails), then the main static switch is turned-on which automatically transfers the ac line to the load. Figure 1 shows the block diagram of on-line UPS.

This paper proposes a new topology for ON-Line UPS. The proposed system, consist of battery charger cum rectifier which is controllable through PIC microcontroller.

Therefore, the battery management will and precise monitoring will be done.

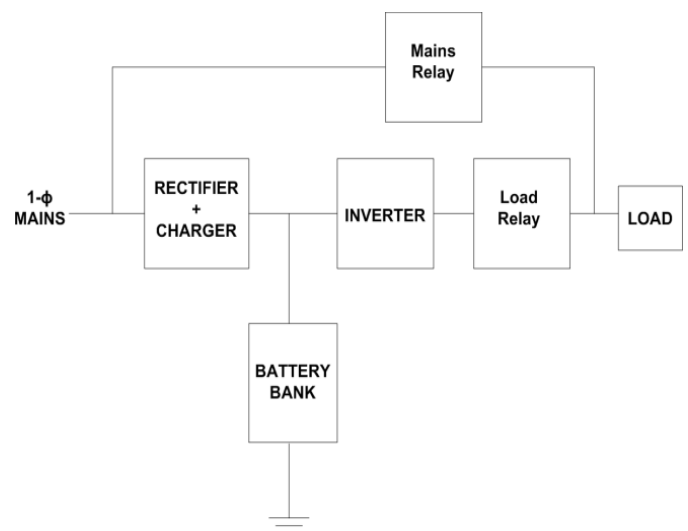

Fig -1: Block Diagram of ON-Line UPS

2. The Proposed Topology:

The AC voltages are applied to Rectifier through the step down transformer and power supply. An uncontrolled rectifier converts AC voltages into DC voltages. The fixed DC is fed to the step-down chopper. The PWM control technique keeps switching frequency constant and also regulates duty cycle to ensure the MOSFET to turn on. In constant current charging method current is set at a fixed rate. Constant current is achieved by switching of the chopper. The step-down chopper produces a lower average output voltage than the input voltage. The battery is connected to the variable DC through the relay. Relay gives the trip on the conditions of overcharging and under discharging. The relays will work as static switches. The switching of inverter is controlled through PIC microcontroller. The battery feeds the inverter. The AC output from inverter will fed to load. Figure 2 shows the block diagram of Proposed Topology.

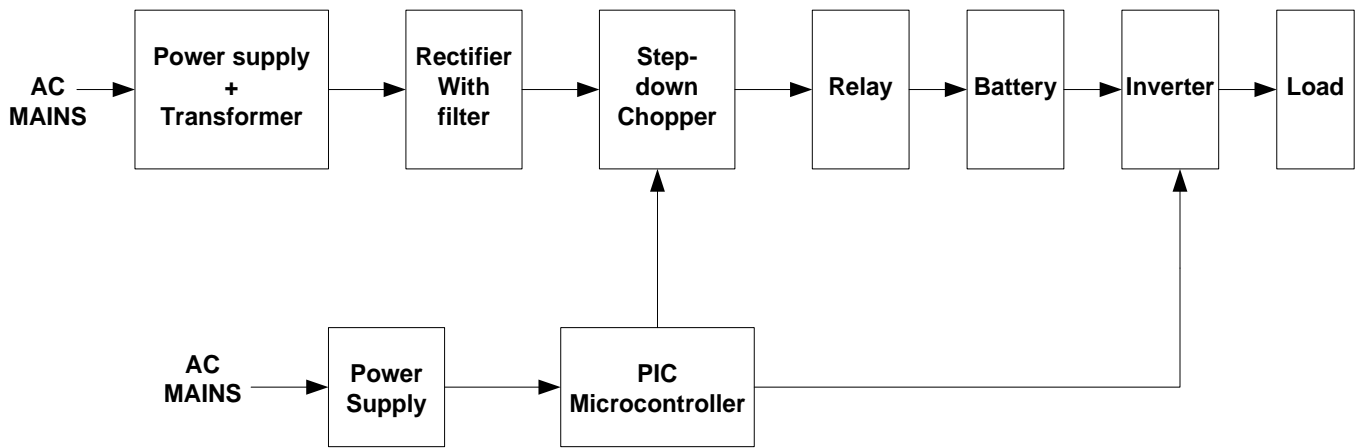

Fig 2: Block Diagram of Proposed Topology

3. Circuit Diagram Consideration for Battery Charger:

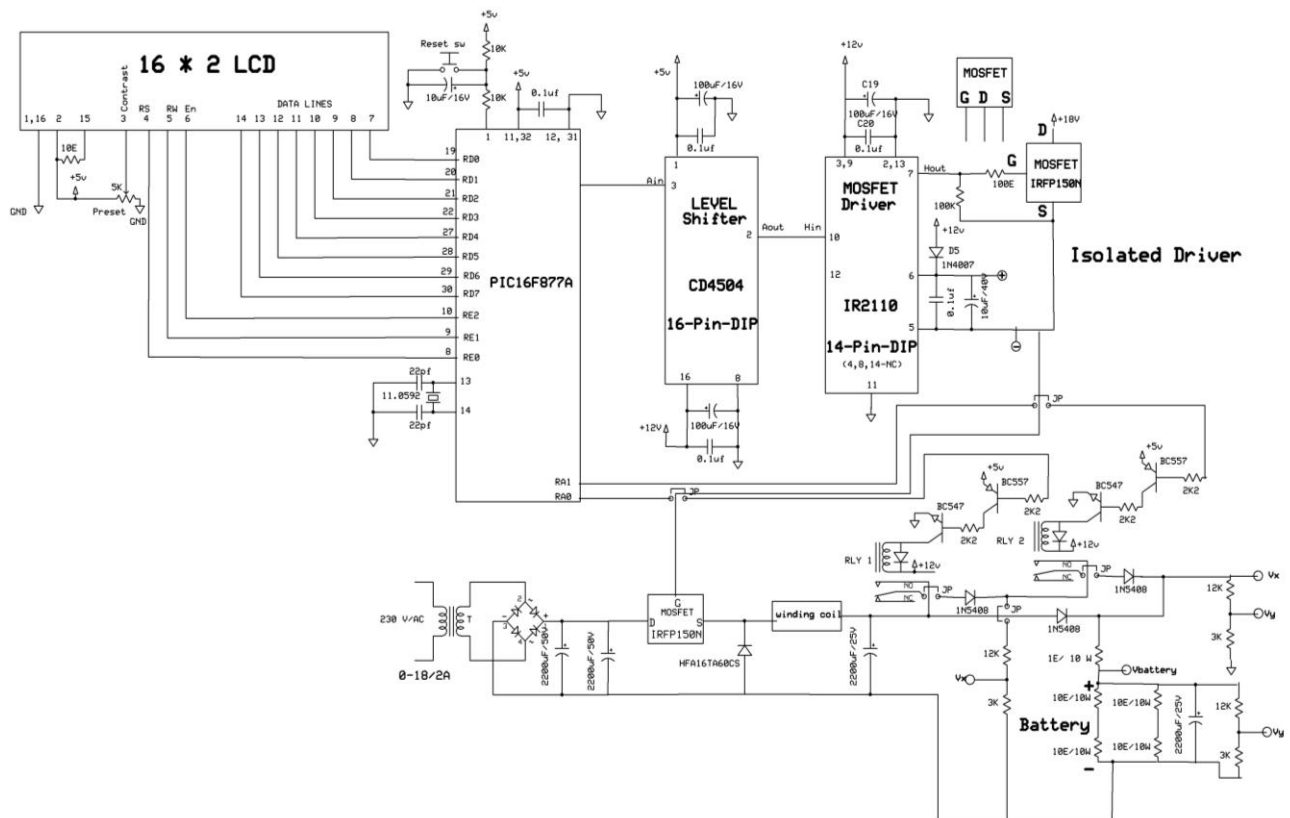

Fig 3: Circuit Diagram of Battery Charger

230 AC voltages are applied to the step down transformer of 0-18 V/ 8 A. The output of 18 V ac is converted into 12 V dc through rectifier. Rectifier with filter capacitor converts AC into 12 V DC. The capacitors of 2200 μ F/ 50 V are used to control the heavy current which may damage the MOSFET switch. The switching frequency of MOSFET switch is 8 kHz.

The turn on time and turn off time of MOSFET controlled through the isolated driver which may also regulates the voltage. The turn on time of MOSFET will be different as for constant current charging. Hence, duty ratio will also be different. The inductor used is toroidal type.

The variable DC is fed to the battery through the resistors of 12 k Ω and 3 k Ω . The voltage sample V_x is taken between 12 k Ω and 3 k Ω resistor. Also, other voltage sample V_y is taken across the battery. The voltage samples V_x and V_y are given to the PIC microcontroller for comparing purpose for constant current charging of battery. When the voltage sample V_y is less than 14 V, the load relay will be turns off, and when the voltage sample V_y is more than 12 V, the load relay will be turns on. Also, when voltage sample V_y is more than 14 V it will increases the duty cycle of step down chopper and when voltage sample V_y is less than 14 V it will decreases the duty cycle of step down chopper.

The output from pin 17 of port C is given to pin 3 of the level shifter CD4504. At pin 1 of CD4504 the supply of +5 V is fed. Also, the capacitors of 100 μ F / 16 V and 0.1 μ F are connected for high and low frequency input noise suppression. The level shifter shifts voltages from +5 V to +12 V (low to high). The output from level shifter CD4504 is fed to pin 10 of MOSFET driver IR2110. The output from pin 7 through the current limiting resistor of 100 Ω is given to the gate terminal of MOSFET.

There are four different conditions:

1. Mains available and Battery fully charged at that time
 - Charger to Battery Relay will be Off and Battery to Load Relay will be On.
 - Also, V_i to be regulated equal to V_b so that battery will not discharge.

2. Mains available and Battery not fully Charged
 - Charger to Battery Relay will be On and Battery to Load Relay will be On.
 - Charging to be regulated so as to keep $I_b < 1$ A
3. Mains fail and Battery not fully charged but not discharged
 - Charger to Battery Relay will be Off and Battery to Load Relay will be On.
4. Mains fail and Battery Discharged
 - Charger to Battery Relay will be Off and Battery to Load Relay will be Off.

4. Circuit Diagram consideration for Inverter:

The push-pull configuration of inverter is used for designing of inverter for ON-Line UPS. For switching operation MOSFET Switches IRFP150 are used. For that MOSFET switches MOSFET driver IR2110 is used. The output from pin 33 and 34 as PWM waveforms are fed to pin 5 and pin 7 of the level shifter CD4504. The level shifter shifts voltages from +5 V to +12 V (low to high). The 12 V output from level shifter CD4504 is fed to pin 10 and pin 12 of MOSFET driver IR2110. The power supply for MOSFET driver IR2110 is connected at pin 6 which is as shown in Figure 4.

When one switch is ON at that time other switch is OFF, therefore dead band circuit is not required for push-pull arrangement of inverter. For MOSFET driver IR2110, isolated power supply is not required because sources of both the MOSFET switches are grounded. The resistor connected at gate of MOSFET is used for current limiting. The capacitors connected across the MOSFET switches are used for snubbing.

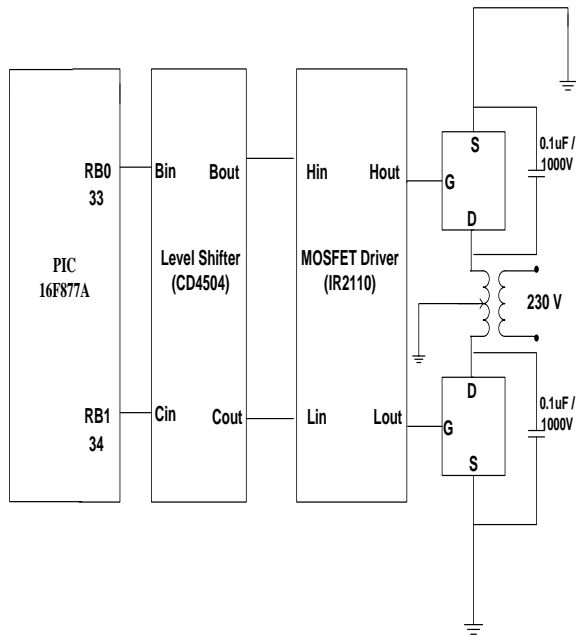

Fig 4: Circuit Diagram of Inverter

5. Flowchart Consideration for PIC Programming:

Figure 5 shows the Flowchart consideration of PIC Programming. The parameters for PIC initialization, LCD initialization and Relay are decided. All the interrupts are disabled and directions of Ports will be decided. Port B will be configuring as output. Relays, mains input, input button and output buzzer are connected at Port B. LCD data lines and control lines are connected at Port D and Port E respectively.

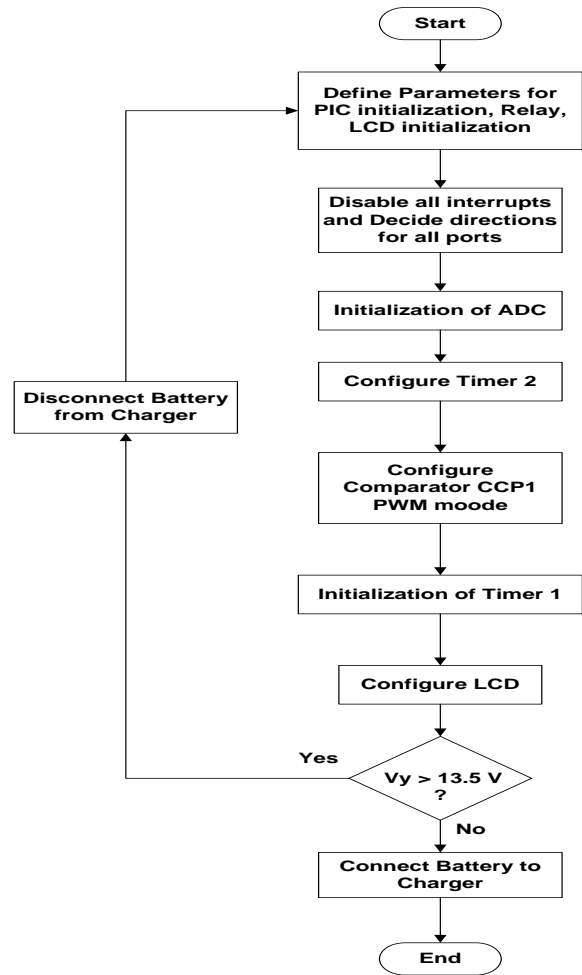

Fig 5: Flowchart Consideration

6. Hardware Results:

The hardware set up of Proposed Topology is shown in Figure 6. The switching waveform of MOSFET switch of battery charger with 8 KHz switching frequency is shown in Figure 7. The switching waveform of inverter switches are shown in Figure 8. The output current and voltage waveforms of the Proposed Topology are shown in Fig 9.

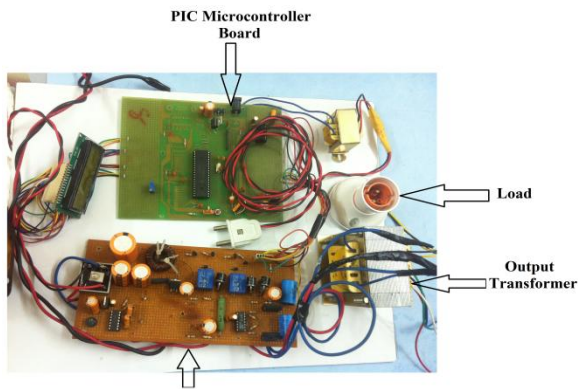

Fig 6: Hardware Set-up

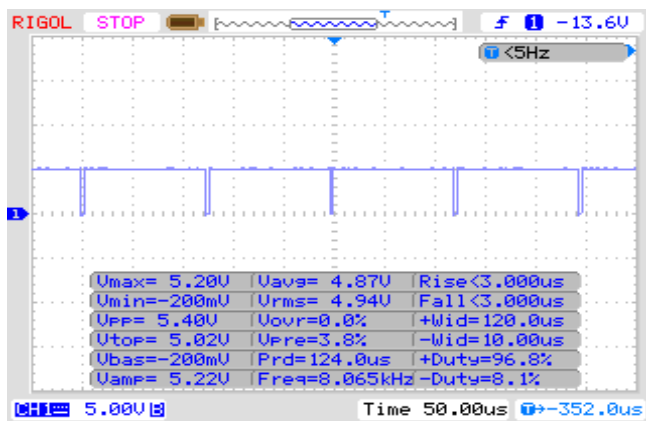

Fig 7: Switching Waveforms of Battery Charger: Switching Frequency: 8kHz

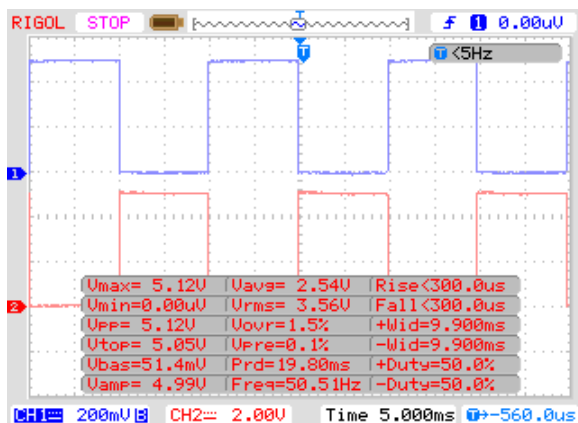

Fig 8: Switching Waveforms of inverter: Switching Frequency: 50Hz

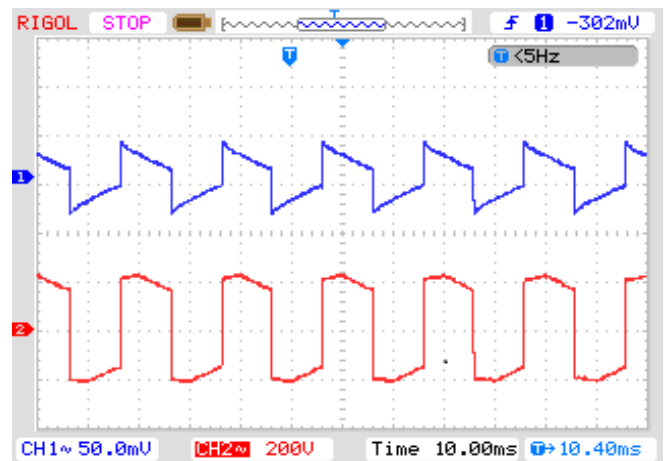

Fig 9: Output Current and Voltage waveforms: Output Voltage: 200V

The output current and voltage are in phase as shown in Figure 10.

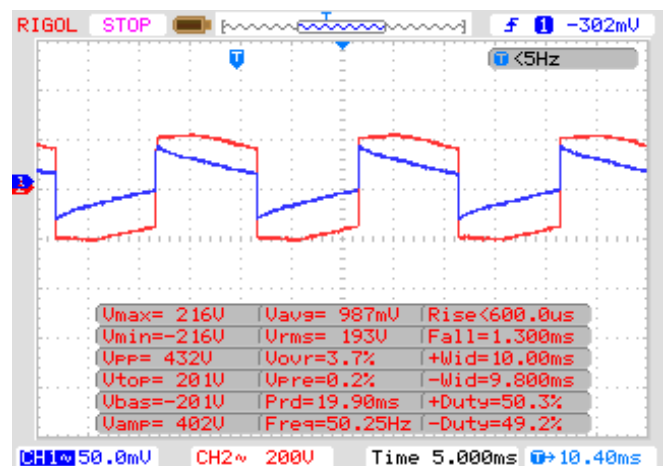

Fig 10: Output Current and Voltage waveforms with phase continuity

7. Conclusion:

The proposed online UPS schemes will full-fill all the characteristics of modern online UPS. The Voltage regulation of 200 Volts AC is available on continuity basis. The advanced microcontroller used for digital controlling is PIC 16F877A. The battery used is Lead-Acid type battery with 12V DC voltage 20A current and 7Ah capacity. Constant current charging is best suited for use on lead-acid batteries. This type of charger is usually small and relatively inexpensive. The basic idea is to keep constant current charging by limiting the duty cycle of charger.

8. REFERENCES:

- [1] Farrukh Kamran and Thomas G. Habetler, "A Novel On-Line UPS with Universal Filtering Capabilities" IEEE TRANSACTIONS ON POWER ELECTRONICS, VOL. 13, NO. 3, MAY 1998.
- [2] L. Bowen, R. Zarr, S. Denton, National Semiconductor Corporation, "A Microcontroller Controlled Battery Fuel Gauge and Charger", 1994 IEEE.
- [3] Stephen P. Sacarisen, Jahangir (J.P.) Parvereshi, "Improved Lead-Acid Battery Management Techniques" Benchmark Microelectronics.
- [4] Shri Karve, "UPS of three kind", IEE Review March, 2000.
- [5] Nasser H. Kutkut, Herman L. N. Wiegman, Deepak M. Divan and Donald W. Novotny, "Design Considerations for Charge Equalization of an Electric Vehicle Battery System" IEEE Transactions On Industry Applications, VOL. 35, NO. 1, January/February 1999.
- [6] Ankur Bhattacharjee, "Design and Comparative Study of Three Photovoltaic Battery Charge Control Algorithms in MATLAB/SIMULINK Environment" International Journal of Advanced Computer Research, Volume-2 Number-3 Issue-5 September, 2012.
- [7] M.Z.U. Khan and C.D. Manning "Microprocessor Controlled Inverter for Ups Applications" Loughborough University of Technology, U.K.
- [8] M. Zafarullah Khan and Cnrlton Dudley Manning, "A HIGH QUALITY MICRO - PROCESSOR CONTROLLED ULTRASONIC PWM INVERTER FOR UPS APPLICATIONS", Loughborough University of Technology, Loughborough, U.K.
- [9] Bo-Yuan Chen and Yen-Shin Lai, "New Digital-Controlled Technique for Battery Charger with Constant Current and Voltage Control without Current Feedback", IEEE TRANSACTIONS ON INDUSTRIAL ELECTRONICS, VOL. 59, NO. 3, MARCH 2012.