

Design & Analysis of Torque Limiter Timer Belt Spindle Drive for Overload Protection

¹Kare Rohan Nandkumar , ²Raut L.B.

¹Lecturer, Mechanical eng , Swami Vivekananda Institute of Technology (Polytechnic) Solapur, Maharashtra, India

² Professor, Mechanical engineering , SVERI'S College Of engineering Pandharpur Solapur, Maharashtra, India

Abstract --- Power is transmitted from motor to output shaft without any interference when no excessive load acting on the machine. But major problem is faced by industry on the machine that is when excessive load will act on the output shaft then problem of overloading make the driving motor or engine to stall; which will lead to burnout of the electric motor. In extreme cases this overload will lead to the breakage of drive elements or the clutch itself. In order to avoid the damage of the transmission elements it is necessary that the input and output shafts be disconnected in case of sudden overloads. The isolation of the input driver member i.e.; motor from the output member is absolutely necessary to avoid damage itself.

Such serious problem which face by the industry can be avoided by use of Torque limiter timer belt spindle drive for overload protection and this can be achieved by the overload slipping ball clutch which is an safety device used in the transmission line to connect the driving and driven elements such that in case of occasional overload the clutch will slip there by disconnecting the input and output members. This protects the transmission elements from any breakage or damage and to cope up with this situation static structural analysis is done on the different parts of Torque limiter such as Base flange, Test rig, output shaft, plunger etc. In this case according to the discussion with company person we will decide to done the static analysis of various parts such as base flange, test rig, output shaft etc.

Key Words: Timer belt, Torque limiter, FEA, Static structural Analysis, Overload protection, Ball clutch.

1. INTRODUCTION

The present work aims for a correct, safe and economical machine working it is necessary .That the component elements of this to be designed and accomplished properly. It is important that, still from the conceiving stage, to work both on the machines and **equipment's gauge and on their reliability (so implicitly on the materials and energy consumptions)**. Taking into consideration all of these, one of the solution is

represented by the use of some safety clutches. In this way, the designers can decrease the value of the safety coefficient for the dimensioning of the mechanical transmissions of **equipment's**. The safety clutches fulfill – besides the main function of the torque transmission and rotational motion transmission between two consecutive elements of a kinematic chain - the function of transmitted torque limitation, in the case of some overloads occurrence, during the performance. In this way it is avoided the kinematic chain elements overstressing and their deterioration. The overloads – that occur in transmission thanks to some causes like machine starting or stopping, the passing through resonance zone, too high overloads of the driven mechanism – can be dynamic (with shocks), with very short duration or quasi-static with long duration. Indifferently of the overloads type, these can lead to the machine deterioration and its retirement. Taking into consideration all overloads, for the transmission calculus, it can lead to an excessive over-measure of this, situation that cannot be accepted. If a safety clutch is assembled in the kinematic chain of the mechanical transmission, then the mechanical properties of the materials, for the transmission component elements can be used to maximum.

The clutches are used largely in machine buildings, and by the correct selection of these depends to a great extent – the safe and long working, both of these and of the kinematic chain equipped with them. The guarantee of these demands, for the mechanical power transmission between shafts, represents a ticklish problem for all areas and engineering applications that require compact, simple and reliable systems. By their advantages, the safety clutches are preferred in different top techniques areas like cars, naval industry and so on.

The main function of the clutches is characteristic to all of them and is the function of transmitting the motion and the torque moment. The other functions, specific to each clutch type are: the motion commanding, the load limitation (with or without interrupting the kinematic flux), the protection against shocks and loads; the compensation of assembling errors; the compensation of the errors which can appear during working; the limiting

of revolution; the one-sense transmission of the motion. All of these functions can appear singularly or concomitantly. Clutch is a mechanism which enables the rotary motion of one shaft to be transmitted, when desired to a second shaft the axis of which is coincident with that of the first.

2. PROBLEM IDENTIFICATION AND PROBLEM DEFINITIO

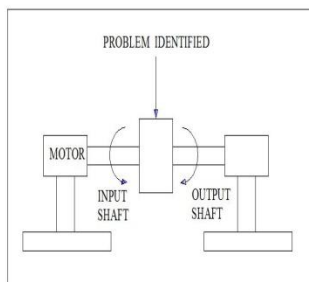

Fig-1: Problem Identification in the Torque Limiter

Above diagram shows that power is transmitted from motor to output shaft without any interference when no excessive load acting on the machine. But major problem is faced by industry on the machine that is when excessive load will act on the output shaft then problem of overloading make the driving motor or engine to stall; which will lead to burnout of the electric motor. In extreme cases this overload will lead to the breakage of drive elements or the clutch itself. In order to avoid the damage of the transmission elements it is necessary that the input and output shafts be disconnected in case of sudden overloads. The isolation of the input driver member i.e.; motor from the output member is absolutely necessary to avoid damage itself.

Such serious problem which face by the industry can be avoided by use of Torque limiter timer belt spindle drive for overload protection and this can be achieved by the overload slipping ball clutch which is a safety device used in the transmission line to connect the driving and driven elements such that in case of occasional overload the clutch will slip there by disconnecting the input and output members. This protects the transmission elements from any breakage or damage and to cope up with this situation static structural analysis is done on the different parts of Torque limiter such as Base flange, Test rig, output shaft, plunger etc. With this I have defined following problems regards with torque tender.

- Excess load on output shaft.
- Incomplete constrained motion.
- Excessive load on the motor.
- Less power transmission by output shaft.
- More power consumption.

3. SCOPE OF WORK

3.1 In many cases pump shaft drives either electrical or engine drives are normally furnished with the overload slipping ball clutch to avoid the breakage or damages arising due to pump clogging or blockage Compressor drives, especially in many mining applications are equipped with the over load slipping ball clutch.

3.2 Compact size: The size of the Torque limiter is very compact; which makes it low weight and occupies less space in any drive.

3.3 Ease of operation: The changing of torques gradual one hence no calculations of speed ratio required for change torque .Merely by rotating adjuster lock nut torque can be changed.

3.4 Machine tool slides are driven by electrical drives connected to lead screw. The over load slipping ball clutch isolates the electrical drive from the output in case of overload.

4. OBJECTIVES OF PROJECT

- To design a Test rig and plunger which easily avoid the excess load acting on the output shaft.
- To prevent the Motor from stalling or burning which cause due to overloading on output shaft by doing static structural analysis.
- To vary Torque carrying capacity by Varying number of Ball & spring sets.
- Integration of the timer pulley set and torque limiter to form final drive system.

5. METHODOLOGY

5.1 Preparation of CAD model.

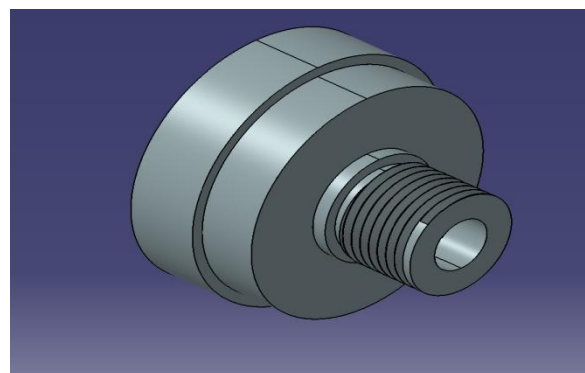

Fig-2: Test rig

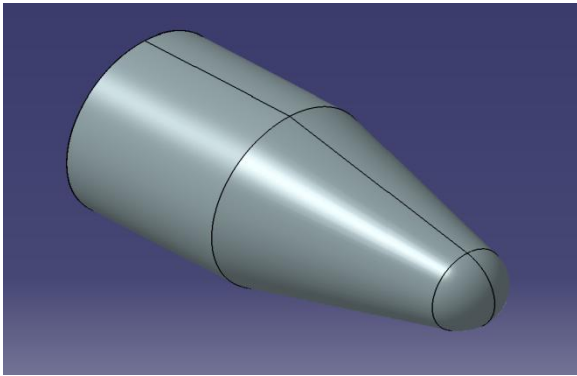

Fig-3: Plunger

5.2 FEA model and meshing by using ANSYS

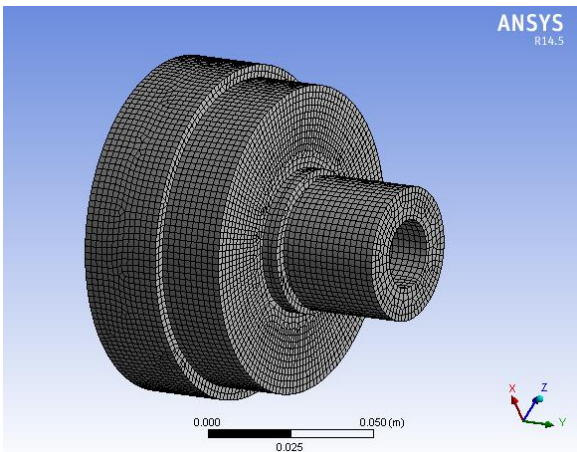

Fig-4: Meshing of Clutch body assembly

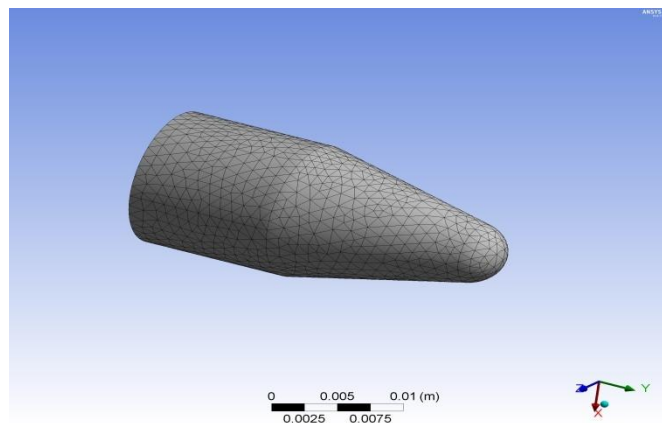

Fig-5: Meshing of Plunger

Meshing of Test rig and plunger can be done in the ansys itself and total number of nodes and element are as shown in the table below.

Table - 1: Number of Nodes and Elements for Meshing.

Sr.No	Name of components	Number of Nodes	Number of Element
1	Test Rig	239095	65233
2	Plunger	34365	23891

5.3 Procedure for Static structural analysis in ANSYS:

Following is the procedure of actual analysis of individual part in torque limiter timer belt pulley.

Part 1: Test rig

The static analysis of base flange is done by means ANSYS Workbench 14.5.7 following are important steps which carried during the analysis

Step 1.

First of all we have to select the analysis type from main menu i.e. static structural analysis. After that we have use drag and drop option in order import the base flange to apply the material properties.

Step 2

In this step we have to call the existing model of Test rig ANSYS Workbench.

Step 3

The most important step is to enter into the analysis window by double clicking on geometry icon.

Step 4

The object which calls in step number 3 is followed by the boundary condition, constraints and mesh tool.

Step 5

To mesh the import model we have to define the method of meshing, size of meshing and element size of mesh.

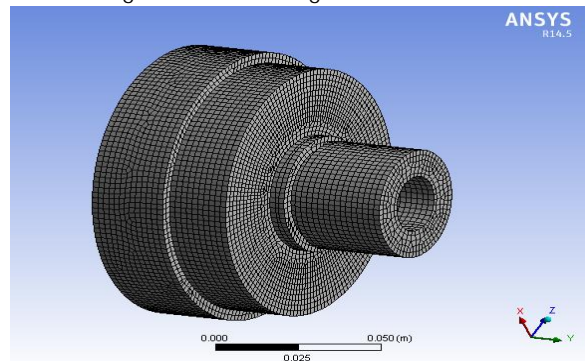

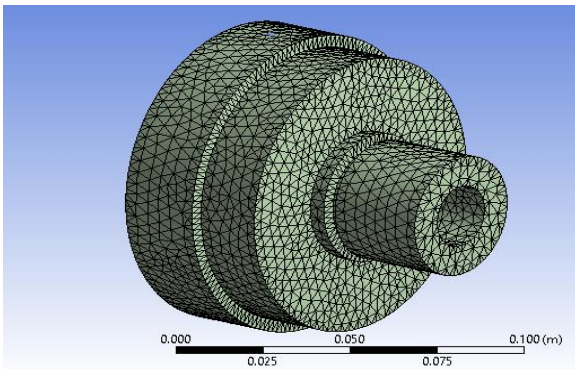

Fig-6: Meshing of Clutch body assembly

Step 6

Now we have to apply the boundary condition like fixed support, force, moment. In this step we fix the outer end of Test rig and apply the moment on extreme end of Test rig.

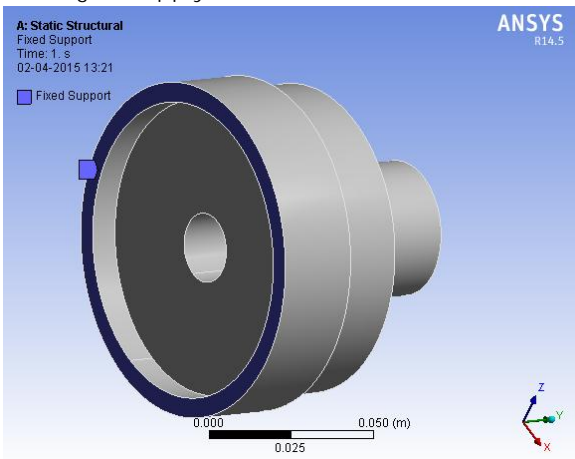

Fig-7: Application of fixed support

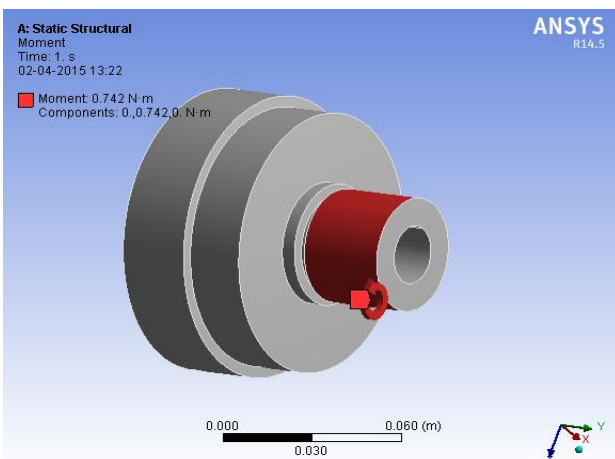

Fig-8: Application of Moment

Step 7

We have to insert the actual parameters that we want like Maximum shear stress. Now solve this analysis by

considering the above stress at each node of the Test rig and it gives the Maximum shear stress regarding static analysis of Test rig. This value of Maximum shear stress executes the safe and failure region in the Test rig.

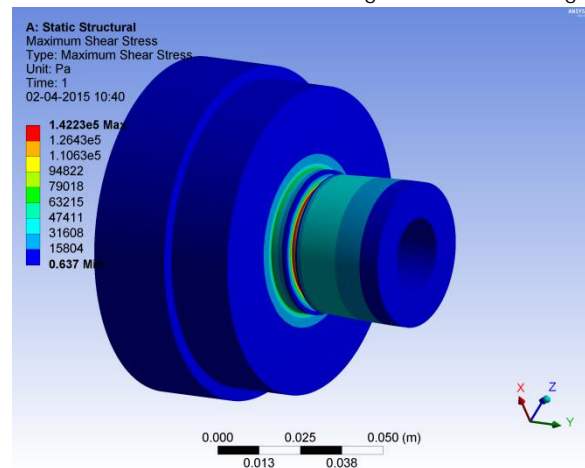

Fig-8: Analysis of Test rig.

Part 2: plunger

For above part same steps are followed to obtain the exact analysis of plunger.

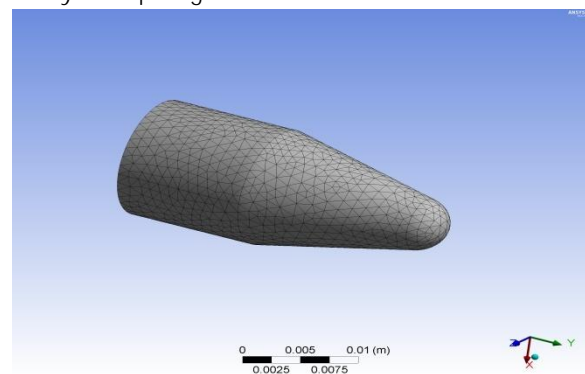

Fig-9: Meshing of Plunger

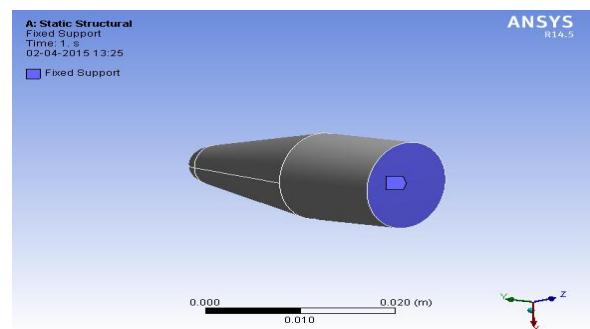

Fig-10: Application of fixed support

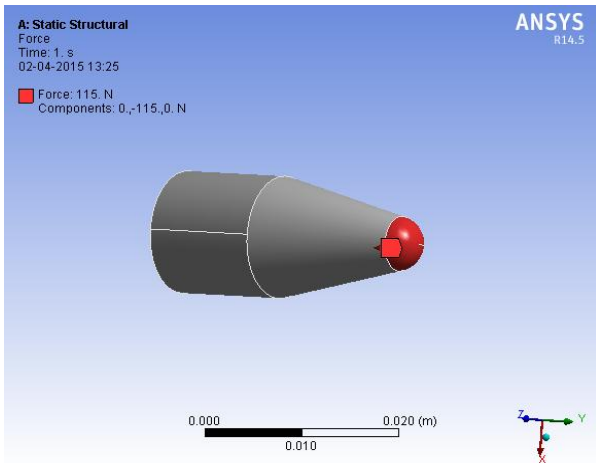

Fig-11: Application of Force

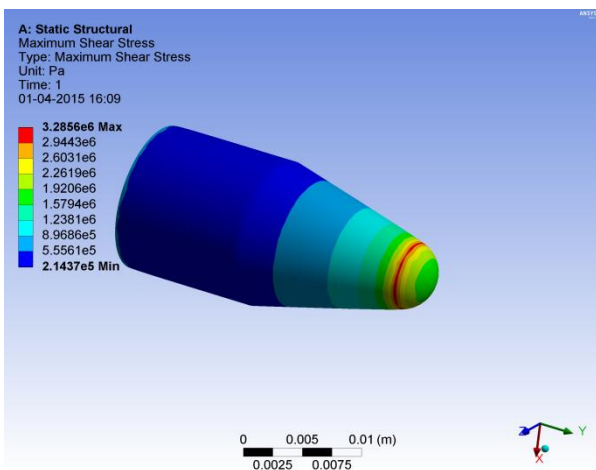

Fig-12: Analysis of Plunger

6. RESULTS AND DISCUSSION

By tabulating theoretical data and FEM analysis along with experimental data, we conclude that the obtained results of each component that is maximum shear stress can be given in table is safe when we compare the value of theoretical, ansys and experimental data with theoretical one.

6.1 For Test Rig

Maximum shear stress (Design data book)	Allowable shear stress (consider Factor of safety)	Actual shear stress (By calcul)	Shear stress in ANSYS	Shear stress in Experiment
---	--	---------------------------------	-----------------------	----------------------------

	10)	ation)		
$900 \times 10^6 \text{ N/m}^2$	$90 \times 10^6 \text{ N/m}^2$	$75.95 \times 10^3 \text{ N/m}^2$	$1.42 \times 10^5 \text{ N/m}^2$	$37.65 \times 10^3 \text{ N/m}^2$

6.2 For plunger

Maximum shear stress (Design data book)	Allowable shear stress (consider Factor of safety 10)	Actual shear stress (By calculation)	Shear stress in ANSYS	Shear stress in Experiment
$900 \times 10^6 \text{ N/m}^2$	$90 \times 10^6 \text{ N/m}^2$	$866.4 \times 10^3 \text{ N/m}^2$	$3.28 \times 10^6 \text{ N/m}^2$	$73.90 \times 10^3 \text{ N/m}^2$

7. CONCLUSIONS

- Excess load acting on output shaft can be reduced by Design and Analysis of Torque Limiter Timer Belt Spindle Drive for Overload Protection.
- The torque carrying capacity can be obtained by varying three number of Ball & spring sets.
- With the help of Integration of the timer pulley set and torque limiter to form final drive system can be achieved.
- In this way stalling of motor can be avoided by design and development of torque limiter.

8. REFERENCES

- [1] I. Stroe., Transilvania University Brasov, Romania. *"Design Procedure of Elastic And Safety Clutches using Cam Mechanisms"*, 12th IFToMM World Congress France.
- [2] Stroe Lone., *"Elastic and safety clutches with intermediate rubber elements"*, Annals of the Oradea University Fascicle of Management and Technological Engineering, Volume IX (XIX), 2010, NR1.
- [3] Nicolae Eftimie., *"Dynamic simulation of the safety clutches with ball"*, Faculty of Technical Science, Novi Sad.
- I. Stroe., Transilvania University Brasov, Romania.
- [4] Guy James Burlington, Stroud (GB) *"Clutch Mechanism"* United states patents, Patent No. US 7,731,618 B2.
- [5] Neal I. *"Simple Mechanical Clutch with Multiple Functions"*. In: *Proceedings of SYROM 2009*, pp. 433-438. I. Visa (Ed) Springer (2009).
- [6] PSG design data book.
- [7] William Silver, Grafton, MA (US) *"Torque Limiter"* United States patents, Patent No. US 8,083,596 B1.