

# COMPARISON OF MODULATION STRATEGIES FOR MULTI LEVEL INVERTER-FED INDUCTION MOTOR DRIVE

Nenavath Sunitha<sup>1</sup> and Dr. S Tara Kalyani<sup>2</sup>

<sup>1</sup> M.Tech, Student, Dept. of Electrical and Electronics Engineering, JNTUHUCEST, Hyderabad, India.

<sup>2</sup> Professor of Electrical and Electronics Engineering JNTUHUCEST, Hyderabad, India.

\*\*\*

**Abstract** - Most multilevel inverter-fed motor drive systems largely use pulse width modulation (PWM) techniques, which give a steady switching frequency, favorable total harmonic distortion (THD) characteristics, and lower ripple current. Harmonic loss is evaluated using several PWM strategies, including In-phase sinusoidal pulse width modulation (IPSPWM), phase opposite sinusoidal pulse width modulation (POSPWM) and space vector pulse width modulation (SVPWM). These techniques are then applied to an induction motor drive for comparison. The suggested methods employ a multilevel inverter to achieve better speed control for induction motor drives. The study compares several modulation strategies in terms of harmonic content, speed, and torque characteristics of the drive system. The major goal is to investigate the effects of various modulation approaches on the performance of a multilevel inverter-fed drive system and which is the best among them. The proposed techniques are implemented in the MATLAB/SIMULINK environment.

**Key Words:** PWM, Induction motor drive, Neutral Point Clamped (NPC) inverter, In-phase sinusoidal PWM, phase opposite sinusoidal PWM and space vector PWM.

## 1. INTRODUCTION

Multilevel inverters (MLIs) have gained a lot of interest in recent years for their use in high-power and high-voltage applications because of their ability to generate higher voltage levels with less harmonic distortion and electromagnetic interference. They are becoming increasingly used in industrial applications, renewable energy systems, and electric drives. When used to drive induction motors, MLIs offer various advantages over standard inverters, including enhanced output voltage quality, increased efficiency, and lower motor stress. Induction motors are frequently utilized in industrial applications because of their reliability, robustness, and low control needs. However, when powered by typical two-level inverters, these motors frequently exhibit substantial total harmonic distortion (THD) and significant power losses. The

use of MLIs can address these concerns, making the system more efficient and reliable. The primary goal of this study is to enhance the performance of induction motor drives by comparing various modulation schemes for multilevel inverters. Understanding the benefits and drawbacks of each strategy allows us to discover the best way for certain applications. By addressing restrictions in solid-state switching device ratings, multilevel PWM inverters enable higher-power adjustable-frequency drives to regulate bigger motors.

### 1.1 Principle of operation of NPC Inverter

There are several uses for three-phase, three-level NPC converters with PWM control in ac machine drives and dc-to-ac power supplies. The performance criteria will be provided to evaluate and compare various PWM techniques [1]. Providing a point-by-point grasp of the neutral point clamped inverter, the three-level NPC inverter is designed and implemented with 12 IGBT switches which includes three phases: Each phase consists of four switching devices (usually IGBTs or MOSFETs), four diodes, and two capacitors. Switching Devices: Each phase leg contains four switches (S1, S2, S3, S4) and four diodes (D1, D2, D3, D4). DC Bus Capacitors: Two capacitors divide the DC bus voltage into two equal portions, forming a neutral point.

Using clamping diodes, the center of each pair is clamped to the center-tapped capacitor's [2]. Controlling the switching devices produces three voltage levels: positive half DC bus voltage ( $+V_{dc}/2$ ), zero (0), and negative half DC bus voltage ( $-V_{dc}/2$ ). When the upper two switches (S1 and S2) are turned on and the lower two switches (S3 and S4) are turned off, the output voltage is  $+V_{dc}/2$ . When the middle switches (S2 and S3) are activated while the outer switches (S1 and S4) are turned off, the output voltage is 0, the current passes from the neutral point (NP) and when the lower two switches (S3 and S4) are turned on and the upper two switches (S1 and S2) are turned off, the output voltage is  $-V_{dc}/2$ . Fig. 1 shows the three phase NPC inverter and induction motor drive as load.

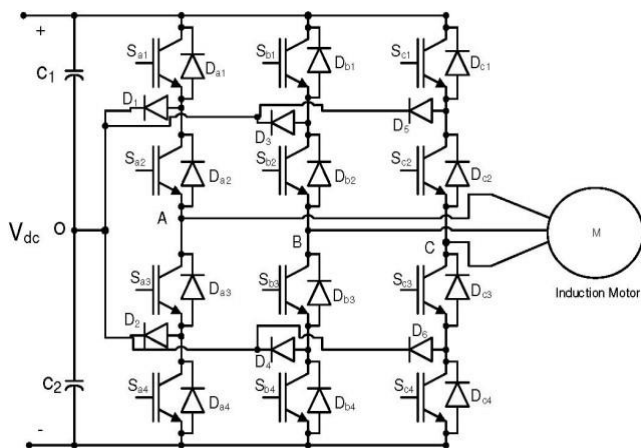
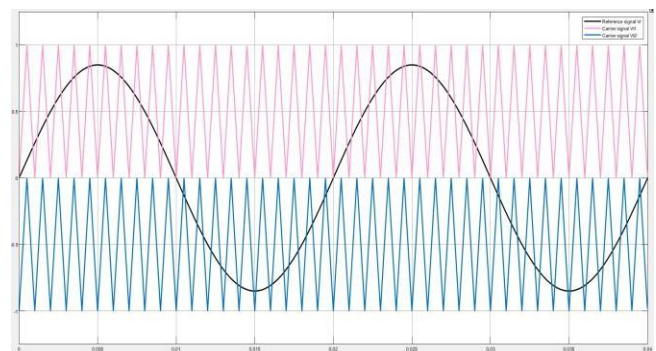

**Fig -1:** Three phase three-level NPC inverter-fed induction motor drive

**2. SINUSOIDAL PULSE WIDTH MODULATION**

When a triangular carrier wave and an input reference waveform intersect, naturally sampled PWM generates switching instants. The carrier wave automatically samples the input waveform, and the sampling instant occurs simultaneously with the output edge. SPWM involves multiplying the input signal's fundamental frequency by the carrier or switch frequency, is typically used with a low pulse number ( $m_f = \frac{f_c}{f_r}$ ). In natural SPWM, spectrum includes the input signal  $f_c$ , carrier  $f_r$ , harmonics  $m f_c$ . To avoid numerous switching edges each switch cycle; The slew rate of the input signal is reduced. The input signal's slope should not surpass the triangle carrier wave's slope, while staying within the boundary.

The bands are continuous for an N-level inverter when N-1 carriers with the same frequency ( $f_c$ ) and peak-to-peak amplitude ( $A_m$ ) are organized. Positioned at the center of the carrier set, the reference or modulation waveform has peak-to-peak amplitude  $A_m$  and frequency  $f_r$ . Every carrier signal and the reference are continually compared. The carrier-associated active device is turned on if the reference signal is greater than the carrier signal. The carrier-associated active device is turned off if the reference is less than the carrier signal. This approach compares two carrier signals ( $V_{t1}$  and  $V_{t2}$ ) with one reference signal ( $V_r$ ). The carrier signal may be IPSPWM or POSPWM. The switching logic is computed in the following ways for both methods. In the positive half cycle of the fundamental, this type of SPWM alternates between states +1 and 0, and in the negative half cycle, it alternates between states -1 and 0. A pair of carriers for a three-level inverter that are all in phase and in opposition to each other.



**Fig -2a:** IPSPWM Technique

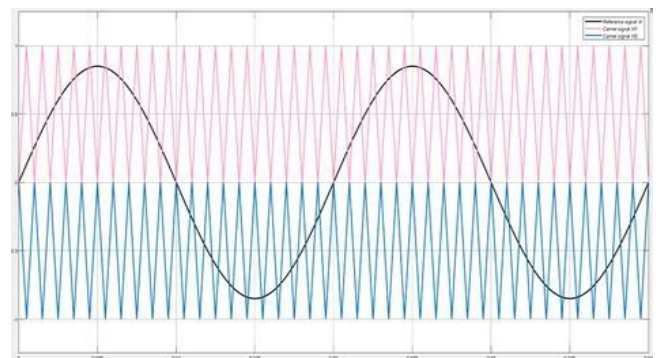

**Fig -2b:** POSPWM Technique

**Table -1:** Circuit parameters of NPC inverter and induction motor rating

DC link capacitor (C1, C2)	470 $\mu F$
DC source voltage	400 V
Input series resistance	0.01 ohm
Frequency	50 Hz
Rated Torque	4.5 N-m
Speed	1500 rpm
Cutoff frequency	700 Hz
Damping factor	0.707

Designing a second order low pass filter for an inverter's three-phase output voltage using the cutoff frequency and damping factor entails developing a filter that not only attenuates high-frequency components but also provides the desired transient response.

$$f_c = \frac{1}{2\pi\sqrt{LC}}$$

$$\zeta = \frac{R}{2} \sqrt{\frac{L}{C}}$$

### 2.1 Simulation Results

The Simulation results illustrate the SPWM approach for the NPC inverter fed induction motor drive. The reference signal's amplitude is 0.85, while the carrier signal's is 1, for both the techniques IPSPWM and POSPWM.

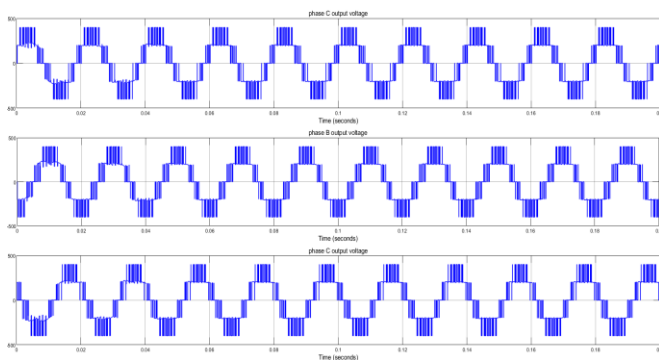

Fig. 3(a)

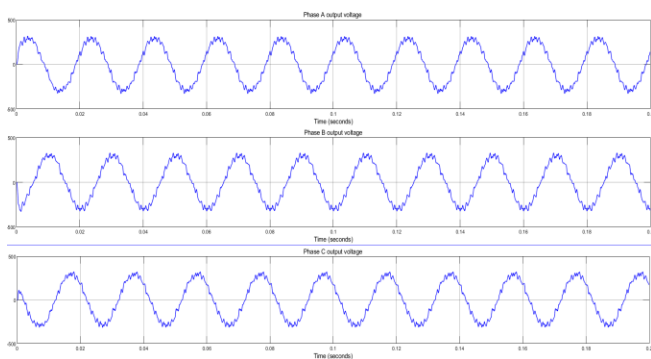

Fig. 3(b)

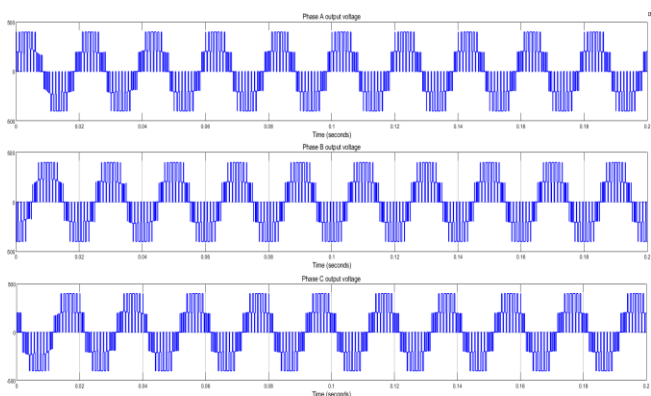

Fig. 3(c)

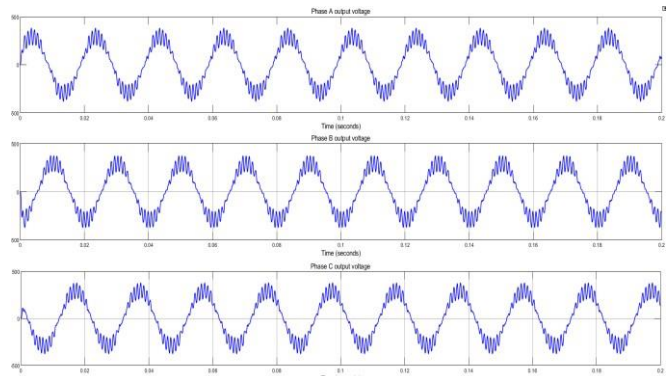

Fig. 3(d)

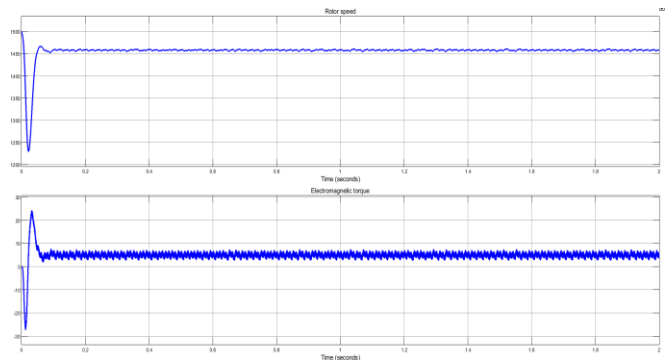

Fig. 3(e)

**Fig -3:** Figures 3(a) and 3(b) shows the line-to-line output voltage of the IPSPWM before and after filters, respectively. Figure 3(c) and 3(d) are line-to-line output voltage of the POSPWM before and after filters, and Figure 3(e) represents the torque and speed characteristics of the induction motor drive.

Since the inverter's output voltage in this case is not sinusoidal from the above simulation result 3(a), 3(c) and has a higher order harmonic dominating, the total transient harmonic distortion (THD) is reduced by employing a low pass filter. Figures 3(b) and 3(d) confirms that the voltage waveform has been enhanced and appears almost sinusoidal after adding filter. At first, the rotor speed exceeds the desired speed, then rotor speed rapidly stabilizes after the initial overshoot and stays mostly stable around a predetermined value shown in fig. 3(e), indicating a steady working condition. At first, the electromagnetic torque fluctuates significantly as the system stabilizes, these variations gradually diminish and reveal damped oscillations. The torque is still oscillating slightly on a regular basis.

### 2.2 FFT Analysis

FFT (Fast Fourier Transform) analysis is used to investigate the frequency components of signals, and it is especially valuable in determining the harmonic content of inverter

output voltages. For a three-phase, three-level inverter, FFT analysis may help in determining the quality of the output waveform as well as the existence and magnitude of harmonics. To transform the time-domain voltage waveforms to the frequency domain, apply an FFT technique. This will offer amplitude and phase information for the frequency components in the waveform. Identify and evaluate the harmonics in the frequency domain representation. Total Harmonic Distortion (THD) is an important statistic in power electronics, notably in inverters.

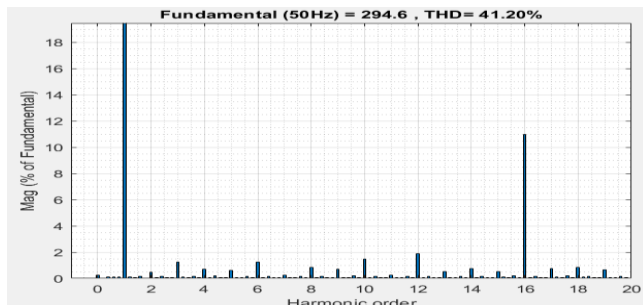

Fig. 4(a)

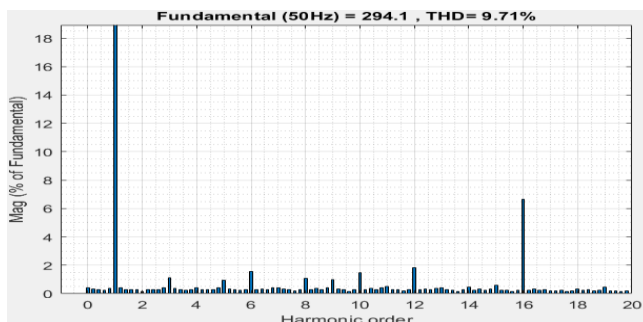

Fig. 4(b)

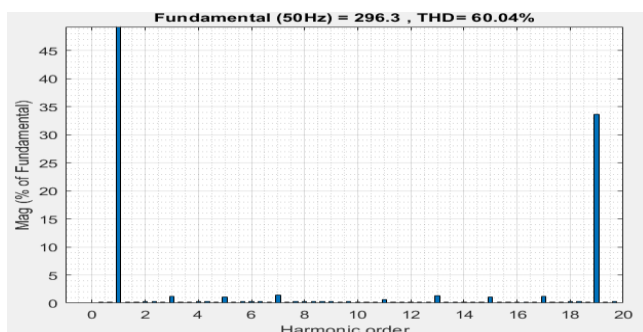

Fig. 4(c)

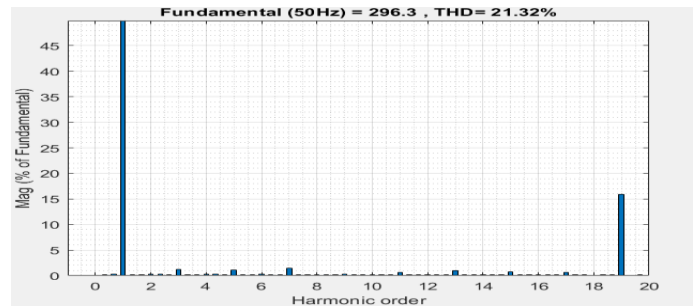

Fig. 4(d)

**Fig -4:** FFT analysis of IPSPWM strategy for NPC inverter shown in 4(a) and 4(b) before and after filter, 4(c) and 4(d) are FFT for the POSPWM before and after filter.

The fundamental frequency (50 Hz) is the largest component, measuring 294.6. The 16th harmonic (about 800 Hz) is the second most significant component, accounting for around 11% of the fundamental. Other harmonics exist but have considerably lesser magnitudes, adding to the overall THD shown in fig. 4(a). after adding filter the 16th harmonic is still present, but its quantity has been reduced to around 6% of the fundamental shows in fig. 4(b). The overall harmonic content is significantly reduced, demonstrating the filter's effectiveness in minimizing harmonic distortion. Overall, the filter significantly improved the waveform, lowering the THD from 41.20% to 9.71% for IPSPWM.

The fundamental frequency was the most significant component, at 293.6. The 19th harmonic (950 Hz) is the second most prominent component, accounting for approximately 34% of the fundamental. Other harmonics exist, but their magnitudes are far lower, contributing to the overall THD shown in fig. 4(c). after employing a filter the 19th harmonic is still there, but its quantity has been reduced to around 16% of the fundamental, as shown in fig. 4(d). The overall harmonic content has been greatly reduced. The filter enhanced the waveform by reducing THD from 60.04% to 21.32% for POSPWM.

## 2. SPACE VECTOR PULSE WIDTH MODULATION

The SVM approach generates three phase voltages with each state switching at a specific time interval. A vector output changes as a result of a voltage vector shifting from sector one to the neighboring sector. The switching state time and patterns must always be understood in terms of a reference voltage vector. The three voltages in phases are:

$$V_r = V_m \sin(\omega t)$$

$$V_y = V_m \sin(\omega t - 120^\circ)$$

$$V_b = V_m \sin(\omega t - 240^\circ)$$

The  $abc \rightarrow \alpha\beta$  (alpha-beta) transformation, or Clarke transformation, turns three-phase variables into two-phase orthogonal components. This transformation makes it easier to analyze and operate three-phase systems by projecting them onto a two-dimensional plane. The Clarke transformation matrix converts three-phase ( $abc$ ) quantities to two-phase ( $\alpha\beta$ ) quantities as follows:  $a$ ,  $b$ , and  $c$  represent the three-phase quantities.  $\alpha$  and  $\beta$  represent the two-phase orthogonal components.

$$\begin{bmatrix} \alpha \\ \beta \\ 0 \end{bmatrix} = \frac{2}{3} \begin{bmatrix} 1 & -1/2 & -1/2 \\ 0 & \sqrt{3}/2 & -\sqrt{3}/2 \\ 1/2 & 1/2 & 1/2 \end{bmatrix} \begin{bmatrix} a \\ b \\ c \end{bmatrix}$$

The Park transformation converts the  $\alpha\beta$  components to a rotating reference frame ( $d$ - $q$  frame). This transformation is useful for evaluating and managing alternating current machines and power converters because it aligns the reference frame with the rotating magnetic field, simplifying equations. The angle  $\theta$  indicates the position of the revolving reference frame in relation to a fixed reference. It can be calculated by integrating the angular velocity ( $\omega$ ) across time. The transformation matrix for transforming  $\alpha\beta$  components to  $d$ - $q$  components is as follows:  $\alpha$  and  $\beta$  represent the stationary reference frame components.  $d$  and  $q$  represent the rotating reference frame components.

$$\begin{bmatrix} d \\ q \end{bmatrix} = \begin{bmatrix} \cos\theta & \sin\theta \\ -\sin\theta & \cos\theta \end{bmatrix} \begin{bmatrix} \alpha \\ \beta \end{bmatrix}$$

$$\theta = \tan^{-1}\left(\frac{V_\alpha}{V_\beta}\right)$$

Three-phase inverters can be controlled with the advanced modulation method known as space vector modulation (SVM). SVM can be expanded to handle the extra voltage levels for a three-level inverter, providing improved harmonic performance and more effective use of the DC bus voltage. Three levels and three phases make up a three-level converter with 27 switching states, such as PPP, OOO, and NNN. Twelve short, six medium, six long, and three null vectors make up the 24 active vectors. There are six sectors created, with four regions (1-4) in each, for a total of 24 regions.

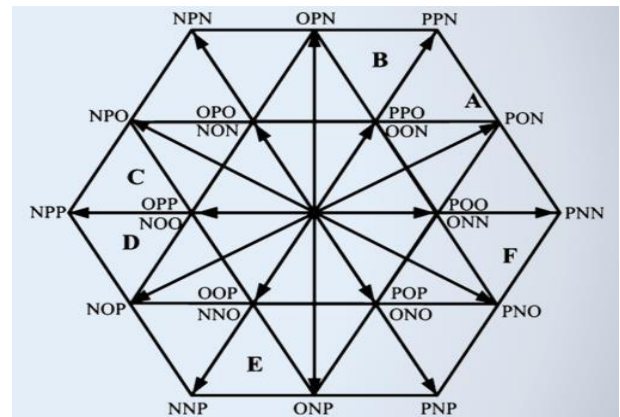

Fig -5: Three phase three level inverter switching states in SVM

Divide the  $\alpha\beta$  plane into six primary sectors (each 60 degrees) and determine where the reference vector falls. A three-level inverter's sectors are further divided into four areas. Choose the three closest vectors that form a triangle around the reference vector. These vectors are chosen according to the sector and the area that contains the reference vector. Calculate the time period for each of the three vectors to be applied inside one PWM cycle to synthesize the reference vector. This is accomplished with the following equations:

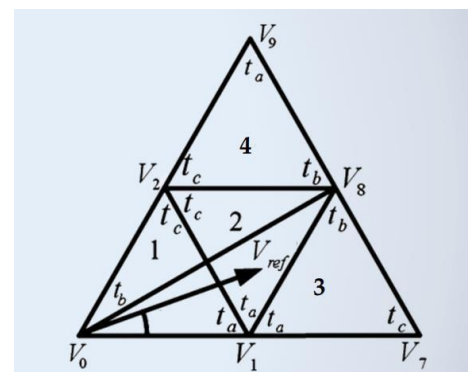

Fig -6: Region division in a sector

Assuming the  $V_{ref}$  remains in region-2, voltage vectors  $V_1$ ,  $V_2$ , and  $V_8$  can be used to accumulate it. The equation of ON time of the voltage vectors can be given as :

$$V_{ref} \times T_s = V_1 \times t_a + V_2 \times t_b + V_3 \times t_c$$

$$T_s = t_a + t_b + t_c$$

$$\text{Modulation index } (m_n) = \frac{V_{ref}}{\frac{2}{3}V_s}$$

Region selection is depend on the modulation index ( $m_n$ ). This modulation index is divided into two parts  $m_1$  and  $m_2$  to know the  $V_{ref}$  is lying in which region. Conditions are applied for the region selection.

If the value of  $m_1, m_2$  and  $(m_1 + m_2) < 0.5$ , then  $V_{ref}$  lies in region-1

If the value of  $m_1$  and  $m_2 < 0.5$  and  $(m_1 + m_2) > 0.5$ , then  $V_{ref}$  lies in region-2

If the value of  $m_1 > 0.5$ , then  $V_{ref}$  lies in region-3

If the value of  $m_2 > 0.5$ , then  $V_{ref}$  lies in region-4

$$m_1 = \frac{2}{\sqrt{3}} m_n \sin \alpha$$

$$m_2 = m_n \left( \cos \alpha - \frac{\sin \alpha}{\sqrt{3}} \right)$$

**Table -2:** On time of the voltage vectors or Switching time for sector A

Region	$t_a$	$t_b$	$t_c$
1	$\frac{4}{\sqrt{3}} m_n T_s \sin \left( \frac{\pi}{3} - \alpha \right)$	$T_s - \frac{4}{\sqrt{3}} m_n T_s \sin \left( \frac{\pi}{3} + \alpha \right)$	$\frac{4}{\sqrt{3}} m_n T_s \sin(\alpha)$
2	$T_s - \frac{4}{\sqrt{3}} m_n T_s \sin(\alpha)$	$\frac{4}{\sqrt{3}} m_n T_s \sin \left( \frac{\pi}{3} + \alpha \right) - T_s$	$T_s - \frac{4}{\sqrt{3}} m_n T_s \sin \left( \frac{\pi}{3} - \alpha \right)$
3	$2T_s - \frac{4}{\sqrt{3}} m_n T_s \sin \left( \frac{\pi}{3} + \alpha \right)$	$\frac{4}{\sqrt{3}} m_n T_s \sin(\alpha)$	$\frac{4}{\sqrt{3}} m_n T_s \sin \left( \frac{\pi}{3} - \alpha \right) - T_s$
4	$\frac{4}{\sqrt{3}} m_n T_s \sin(\alpha) - T_s$	$\frac{4}{\sqrt{3}} m_n T_s \sin \left( \frac{\pi}{3} - \alpha \right)$	$2T_s - \frac{4}{\sqrt{3}} m_n T_s \sin \left( \frac{\pi}{3} + \alpha \right)$

### 3.1 Simulation results

When it comes to voltage utility, space vector PWM for three-level converters has a benefit over sinusoidal PWM since its modulation range is 15% greater. The steps are as follows: first, determine the reference vector; next, choose the sector; last, choose a specific area within which the reference vector is located. determining the timing of each of the three vector forming triangle and distributing the relevant PWM switches on time.

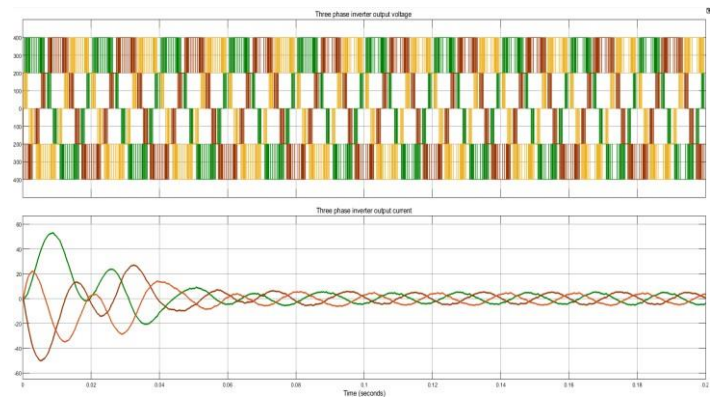

Fig. 7(a)

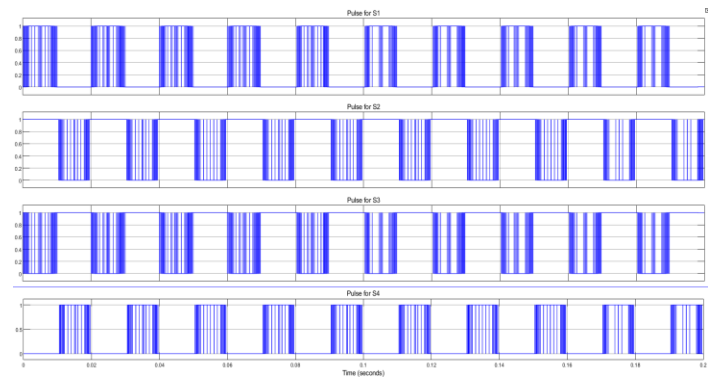

Fig. 7(b)

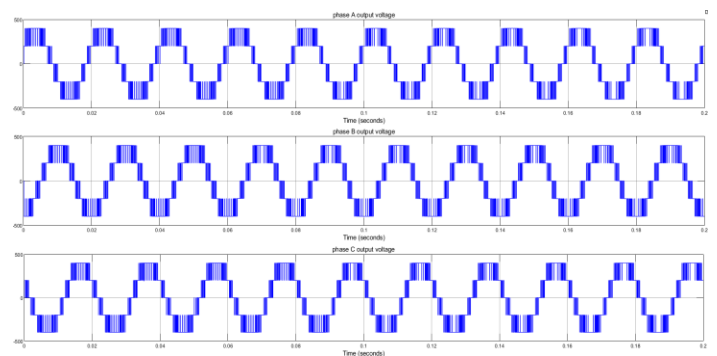

Fig. 7(c)

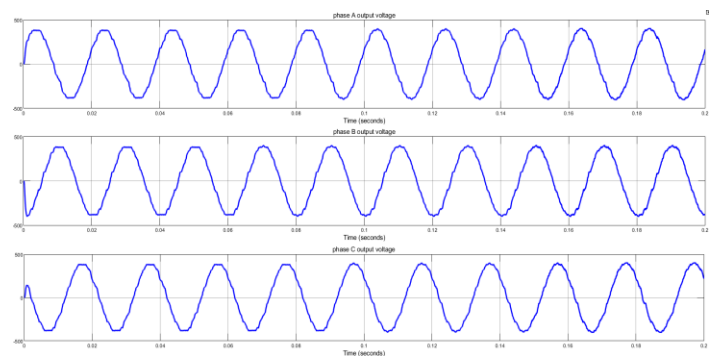

Fig. 7(d)

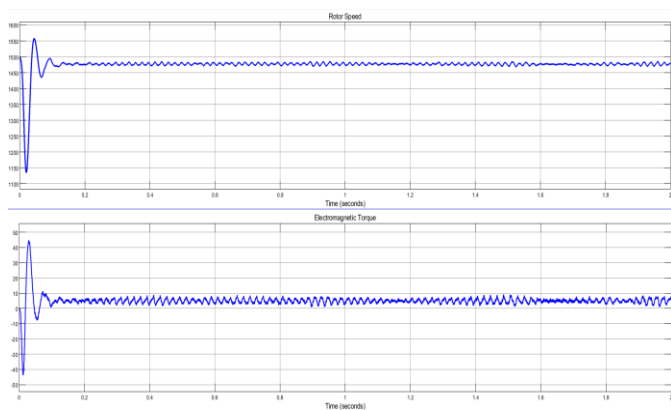

Fig. 7(e)

**Fig -7:** Figure 7(a) demonstrated the output voltage and current of the three-level, three-phase inverter. Figure 7(b) indicates the switching pulse for the inverter switches, and the RMS line-to-line voltage for the three phases before and after the filter is shown in 7(c) and 7(d). 7(e) depicts the drive system's characteristics.

Initially, there is a transitory response. After the transient period, the currents settle into sinusoidal waveforms, indicating steady-state performance in a balanced three-phase system this is confirmed from fig. 7(a). From fig. 7(b) the topmost figure displays the PWM signal for one of the inverter's switches (S1). The second panel shows the PWM signal for another switch (S2) in the inverter. The switching pattern here is phase-shifted when compared to S1, which is required to generate the proper phase relationship in the output voltages and so on. The graphs 7(c) illustrate staircase-like waveforms caused by the inverter switching between voltage levels. After applying a filter to the output voltage, when compared to the SPWM method, it was shown to be pure sinusoidal. It was found that the speed-torque characteristics of SVPWM bettered than SPWM in terms of performance.

### 3.2 FFT Analysis

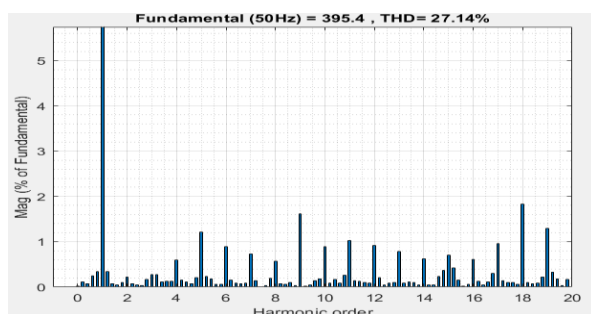

Fig. 8(a)

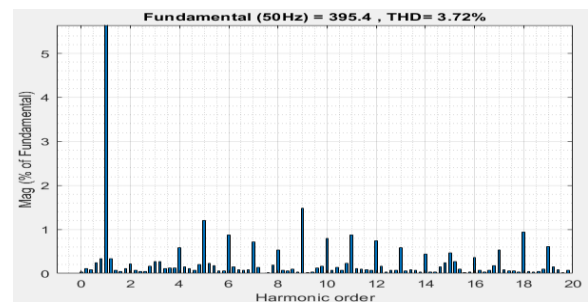

Fig. 8(a)

**Fig -8:** 8(a) and 8(b) shows the FFT for the SVPWM technique before and after filter.

There is a 50 Hz fundamental frequency. The magnitude of the fundamental component has been adjusted to 395.4%. The THD is 27.14%, suggesting a high level of harmonic distortion relative to the fundamental component. There are detectable harmonics in the 2nd, 3rd, 5th, 7th, 9th, 11th, 13th, 15th, and 17th orders. Some of these harmonics have larger magnitudes, which add to the overall THD, this can be seen in fig, 8(a). The magnitude of the fundamental component remains at 395.4%. Adding a filter to the NPC inverter-fed induction motor drive drastically lowered Total Harmonic Distortion from 27.14% to 3.72%. Previously strong harmonics at orders such as the second, third, fifth, and others have much smaller magnitudes. The addition of a filter significantly reduced the magnitudes of both lower and higher order harmonics which can be confirmed from the fig. 8(b).

### 4. COMPARISON

**Table -3:** Comparison of %THD of inverter line-to-line output voltage with IM

Sl.NO	Various modulation Strategy	Before Filter	After Filter
1.	In-phase SPWM	41.20%	9.71%
2.	Phase-opposite SPWM	60.04%	21.32%
3.	Space Vector PWM	27.14%	3.72%

The motor speed control using SPWM was steady but exhibited small variations due to the increased harmonic content, whereas SVPWM resulted in smoother and more stable speed control, with less harmonic distortion. Torque produced by SPWM showed some ripple, which was credited by the greater harmonic content. The torque performance with SVPWM was superior, with less ripple and smoother torque characteristics due to decreased harmonic content.

### 3. CONCLUSIONS

Comparison of modulation strategies for multilevel inverter fed induction motor drive was carried out to determine the performance of three control strategies for three level NPC inverter. The study aimed to achieve THD of the inverter output voltage and speed-torque characteristics of the drive system for the three strategies. The findings showed that SVPWM control technique offers more accurate switching than the other two strategies, although IPSPWM, POSPWM, and SVPWM are all suitable for controlling the switching of the inverter devices to provide the necessary output voltage waveform. Improved speed-torque characteristics and less harmonic distortion are two other reasons why SVPWM is a better choice for high-performance applications. In broadly, this research focuses light on the possible advantages of three distinct strategies for NPC inverter-fed induction motor drives that operate in three phases and three levels.

### REFERENCES

1. R. K. Behera, T. V. Dixit and S. P. Das, "Analysis of Experimental Investigation of Various Carrier-based Modulation Schemes for Three Level Neutral Point Clamped Inverter-fed Induction Motor Drive," 2006 International Conference on Power Electronic, Drives and Energy Systems, 2006, pp. 1-6, doi: 10.1109/PEDES.2006.344417.
2. K. Reddy Sudharshana, V. Muralidhara, A. Ramachandran and R. Srinivasan, "Analysis of Total Harmonic Distortion in 5-level Inverter fed Induction Motor," 2018 International Conference on Computing, Power and Communication Technologies (GUCON), Greater Noida, India, 2018, pp. 800-804, doi: 10.1109/GUCON.2018.8674891.
3. A. Nabae, I. Takahashi, and H. Akagi, "A new neutral-point-clamped PWM inverter," IEEE Trans. Ind. App., vol. IA-17, pp. 518-523, Sept./Oct. 1981.
4. D. G. Holmes, "A general analytical method for determining the theoretical harmonic component of carrier based PWM strategies," in Conf: Rec. IEEE- IAS Annu. Meeting, 1998, pp. 1207-1214.
5. J. Holtz, "Pulsewidth Modulation for Electronic Power conversion," Proceedings of the IEEE, Vol. 82, No. 8, Aug. 1994, pp. 1194-1214.
6. H. S. Black, Modulation Theory, D. Van Nostrand Company, Inc, Princeton, 1960.
7. B. Velaerts, P. Mathys and E. Tatakis, "A Novel Approach to the Generation and Optimization of three level PWM waveforms," in Proc. IEEE PESC'88. Conf., 1988, pp. 1255- 1262.
8. D.G. Holmes and T. A. Lipo, "Pulse Width Modulation For Power Converters Principles and Practice, IEEE press series on Power Engineering, IEEE Press, Wiley-Interscience, Piscataway, 2002.
9. G. K. Dubey and C R. Kasarabada, Power Electronics and Drives, IETE Book Series. Vol. I. Tata-Mc Graw Hill, 1993.
10. Y. Liu, X. Wu, and L. Huang, "Implementation of three-level inverter using a novel space vector modulation algorithm," in IEEE Conference Proc. on Power System Technology, vol. 1, pp.606-610, Oct. 2002.
11. B. Muralidhara, "An Experimental Evaluation of Two level and multilevel inverter used for speed control of Induction Motor and study of Common Mode Voltage in both cases".
12. G. Narayanan, and V.T. Ranganathan, "Synchronised PWM strategies based on space vector approach : Principles of waveform generation", IEEE Proceedings- Electric Power Applications, vol 146 No.3, May1999, pp. 267-275.
13. Nashiren F. Mailah, Senan M. Bashi, Ishak Aris, Norman Mariun "Neutral-Point-Clamped Multilevel Inverter Using Space Vector Modulation" European Journal of Scientific Research, Vol.28 No.1 (2009), pp.82-91.
14. Reddy Sudharshana K, A Ramachandran, V Muralidhara and R Srinivasan, "Simulation with Experimental Measurement of Voltage Total Harmonic Distortion and Harmonic Frequency in Three-Phase Induction Motor fed from Inverter", in WCE proceedings, July 2017, pp.317-322
15. P. Hothongkham and V. Kinnares, "Investigation into Harmonic Losses in a PWM Multilevel cascaded H-Bridge Inverter Fed Induction Motor," 2007 7th International Conference on Power Electronics and Drive Systems, 2007, pp. 1043-1048, doi: 10.1109/PEDS.2007.4487832.