

Landmine Detection Robot with Live Surveillance

Sattyen Shedge¹, Aniket Shinde², Ritu Kumari³, Prof. (Ms.) A. B. Kale⁴

¹Student, Electronics & Telecommunication Engineering, Sinhgad College of Engineering, Vadgaon

² Student, Electronics & Telecommunication Engineering, Sinhgad College of Engineering, Vadgaon

³ Student, Electronics & Telecommunication Engineering, Sinhgad College of Engineering, Vadgaon

⁴ Assistant Professor, Electronics & Telecommunication Engineering, Sinhgad College of Engineering, Vadgaon

Abstract - Nowadays in war-torn communities around the world, landmines are causing immense civilian casualties. A land mine is an explosive device, which is meant to destroy or disable enemy and buried under or on the ground, especially in the mined countries like Afghanistan and Iraq. Accordingly, the majority of land mines are located under the ground surface and are triggered by pressure or trip-wire. Mostly the surface of the landmines will have many metallic pipes for the detection purpose. The mines lying amid the war time may remain unfounded. To conclude, as the name implies, Metal Detector Sensor is used in this case and can be done deeper into the mine more precisely. This project relates to the concept of designing and implementing the robotic vehicle which is able to locate the landmine and indicates their places via text message to the respective authorities. A live surveillance system will be available in the robotic vehicle, which will also increase the visibility and safety. The special function of this robot is to deliver ammunition to dogface that are in the hard-to-reach area during war without human loss. In addition to that, it can be employed to target deadly places in advance for losers and munitions at the same time. It is expected that the robot will possess the ability to identify and mark landmines, avoiding stepping on those mines and shooting live images to authorities thereby reporting the hazard. questions and other colorful ones in this area have caused us to improve the mine-detecting robots.

Key Words: Landmine Detection Robot, metal detector, ATmega328 IC, GSM module, ESP32-CAM module, DC motors, motor driver.

1.INTRODUCTION

In warfare, most of the antecedents are made by buried landmines. The unexploded landmines take many lives even after closing of a conflict. Brutal parcels of landmines are once it's active, it can be operable for a genuinely long time. Hence, there's always a danger of fatalities damage and injury causing death. Landmines became effective ammunition in warfare as it's cheap and easy to make. Mostly, it consists of snare along with some driving medium. Driving may be caused by weight. Depending upon weight it demanded to get touched off there are many types of landmines. When ready, they are buried at a shallow depth in soil and hence not fluently get mindful with naked eyes. You can give landmine over to someone and if the person

puts the landmine on the ground, it will make an explosion killing the person.

Landmines can be buried in certain patterns to surround movements of an adversary. They can be buried in a zigzag pattern to slow the movement of the adversary as they flee or they be placed in such a way to force the adversaries to leave their path and lead them into an ambush. Due to these numerous features, they are placed to be very effective armament as they can be buried easily, they remain undetected, and they are in such place for a great amount of time. This paper will include an overview of the beings and latest ways created for the discovery of landmines. Electronics had played a great role in the development and successful application of some of these ways.

Many ways that are bandied then includes the use of metal sensors, mechanical styles. Working, advantages and limitations of each fashion are bandied. The performance of the discovery system can be enhanced by using multiple ways.

2.Proposed Method

The approach I have considered using for the landmine detection robot project is to employ ATmega328 IC to gather data from metal detector and the ESP32-CAM module and also to send this information to GSM module. The GSM module also will utilize the sent data and inform the concerned authorities about the area of landmine hazard.

Two dc motors interfaced with the motor driver will be used for the vehicle movement.

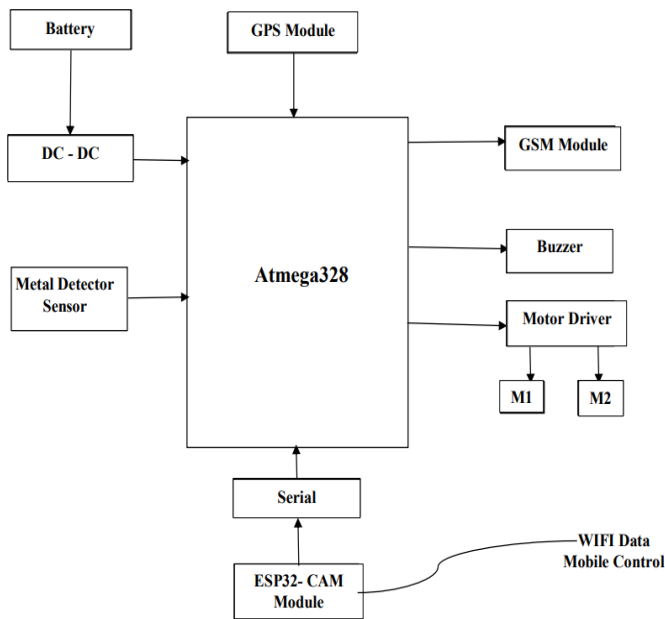

Fig. 1: System Block Diagram

2.1 Hardware Components

2.1.1 Metal Detector Sensor

A metal detector sensor module is the device that is based on the ability of metals to be detected due to the electromagnetic induction. Usually, this type of module presupposes that there are two coils, one of which is transmitter coil, while the other is the receiver coil. The field is formed due to the transmitter's presence, and the receiver is able to detect any changes in it, caused by the metal body. When the metal object approaches the sensor, its field is distortion, and the sensor produces the output signal, marking the appearance of some metal object.

Features:

- Adjust the potentiometer to vary the detection range and strength.
- Small and easy to use the module.
- It comes with a Buzzer, for metal detection indication.



Fig. 2: Metal Detector Sensor

2.1.2 ATmega328

ATmega328 is a low-power CMOS 8-bit microcontroller based on the AVR enhanced RISC architecture. By executing powerful instructions in a single clock cycle, the ATmega328 achieves throughputs approaching 1 MIPS per MHz allowing the system designer to optimize power consumption versus processing speed.

Features:

- Low power consumption.
- Real timekeeper counter having separate oscillator.
- 6 PWM legs.
- Programmable periodical USART.
- Programming cinch for software security.



Fig. 3: ATmega328

2.1.3 GPS Module (SIM28ML)

The SIM28ML is a high-performance GPS receiver module manufactured by SIMCom. This standalone module is commonly known for its small size, robustness, durability, reliableness, and low power consumption. The most important features of the product are as follows:

- High Sensitivity: Utilize a high-sensitivity navigation engine with an accurate location at weak signal conditions down to -165dBm, without network assistance function.
- Fast TTFF: Adopt a fast time-to-first-fix – TTFF function for capturing the accurate location of the GPS quickly.
- Low Power Consumption: Born with an extremely low-power design – power consumption is at 17mA while acquiring and 16mA while tracking.
- Compact Size: The SIM28ML is supplied in a small package LCC format having a small footprint of 10.1 x 9.7 x 2.5 mm.

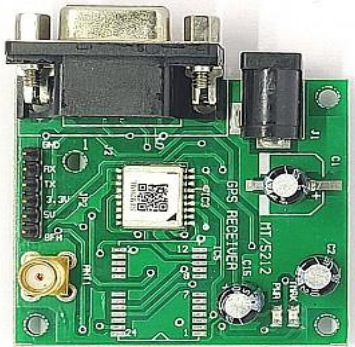

Fig. 4: GPS Module (SIM28ML)

2.1.4 GSM Module (SIM800L)

A quad-band GSM/GPRS module that operates at frequencies GSM850MHz, EGSM900MHz, DCS1800MHz, and PCS1900MHz, is as follows. The modem's GPRS multi-slot capability is either class 10 or 12. The four coding schemes supported by it are CS-1, CS-2, CS-3 and CS-4. As long as space is concerned, the configuration of the tiny SIM800C is 17.6×15.7×2.3mm, and it can be used to satisfy all of the customers' requested forms in applications.

Features:

- One 3 lines serial port and one full modem serial port;
- One USB, the USB interface can debug, download software;
- One audio channel which include a microphone input and a speaker output;
- Support Bluetooth: (need software support)



Fig. 5: GSM Module (SIM800L)

2.1.5 ESP32-CAM Module

The ESP32-CAM is a cost-effective ESP32-based development board with a tiny size camera onboard. It is well suited for IoT application, prototypes and DIY projects. The board features Wi-Fi, Bluetooth 4.2, and low energy BLE with 2 high performance 32-bit LX6 CPUs. It employs a 7-stage pipeline architecture, an on-chip sensor, hall sensor,

temperature sensor, etc. The main frequency ranges from 80MHz to 240MHz.

Features:

- Up to 160MHz clock speed, Summary computing power up to 600 DMIPS
- Built-in 520 KB SRAM, external 4MPSRAM
- Supports UART/SPI/I2C/PWM/ADC/DAC
- Support OV2640 and OV7670 cameras, Built-in Flash lamp.
- Image WIFI upload



Fig. 6: ESP32-CAM Module

2.1.6 Motor Driver (L298N)

It is a simple dual bidirectional motor driver based on the popular L298 Dual H-Bridge Motor Driver Integrated Circuit. The circuit will allow you to easily and independently control two motors of up to 2A each in both directions. It is ideal for robotic applications and well suited for connection to a microcontroller requiring just a couple of control lines per motor. It can also be interfaced with simple manual switches, TTL logic gates, relays etc.

Features:

- Input Voltage 3.2V-40V dc
- Driver: L298N Dual H Bridge DC Motor Driver
- Power Supply: DC 5 V – 35 V
- Peak current: 2 Amp
- Operating current range: 0-36mA
- Maximum power consumption: 20W (when the temperature T = 75 °C).
- On-board +5V regulated Output supply (Supply to controller board i.e. Arduino)
- Size: 3.4cm x 4.3cm x 2.7cm



Fig. 7: Motor Driver



Fig. 9: Arduino IDE

2.1.7 Gear Motor:

A gear motor is a special motor in which high torque is produced while the horsepower or the speed of the motor is kept low. A gear motor is mostly used in devices such as a can opener, garage opener, washing machine time control knob, electric alarm clock and others like hospital beds, commercial jacks, cranes industrial lifting etc. in the commercial.

Features:

- The motor runs quite simply at 4V to 12V gives a wide range of RPM and torque, although, it gives 100 RPM at 12v.
- A hole into shaft is given for better coupling.
- Operating Voltage(V): 12
- Rated Torque(kg-cm): 2.9
- Stall Torque(kg-cm): 11.4



Fig. 8: Gear Motor

2.2 Software Components

2.2.1 Arduino IDE

Arduino IDE is a free application that allows an individual to write and upload code on an Arduino board. It is a cross-platform application for Windows, Mac, and Linux. Arduino IDE is based on modified C++ written into Arduino boards. It is derived from the processing programming language.

3) System Flowchart

Step 1: Setting Up an I/O Port Point.

First, the microcontroller of the robot should be capable of interacting with the outside world, so an I/O port should be established, which is the interface that the robot provides. With the help of it, the robot will be able to send/receive the information to/from the GSM module and the buzzer. The pin assignment layout of the microcontroller will be determined in order to choose the engine to active the I/O port of the robot. One can also set an oscilloscope to examine them and to do one of the tasks, for example, you can set these pins to be input or output and chose the voltage setpoint for them all.

Step 2: Provide signal data.

Metal detector is mainly a probe used for determining metals. Robot uses metal detector for discovering spots that metal is supposed to be present on landmines.

The voltage level from the pin of metal detector to help the robot's microcontroller math volunteer for getting the sensor data. The robot can detect a mine in the scanning zone once the current, which the sensor source, exceeds a specific level of the sensor criticality.

Step 3: Read sensors data.

As the next Step, the robot needs to process this sensor data and form conclusion, whether it found a landmine or not.

In the previous steps, we described that microcontroller needs to change the level of signal of the sensors data pin into the binary one, the output pin is the microcontroller. So, only when the robot decodes the higher-order digit values and sees whether a particular threshold value has been overridden.

Therefore, it can make a conclusion that a robot has recognized a signal of a landmine.

Step 4: The Device Will Send a Short Message Service Alert and Buzz.

The machine clearing route has to report remotely and sound alarm should it detect any mines. To achieve this the microcontroller of the device has to do some work to provide data and send the SMS to available number. This callable GSM module calls the robot to execute commands via the serial port. At the input of the buzzer's pin, it gives a signal which allows the robot's microcontroller to be capable of "buzzing" the buzzer. Therefore, the high voltage will be fed at the input's pin of the buzzer in order for the robot to achieve this.

Movement and stop of the robot should be indicated by the buzzing sound and corresponding GSM message. This statement is made due to the fact that a robot lacks the ability to guard its surroundings from damages and may also be a threat to other people. The microcontroller of this robot uses the brake function by the cause of the motor's controlling signals sent by microcontroller to stop moving the robot.

Step 5: Stop

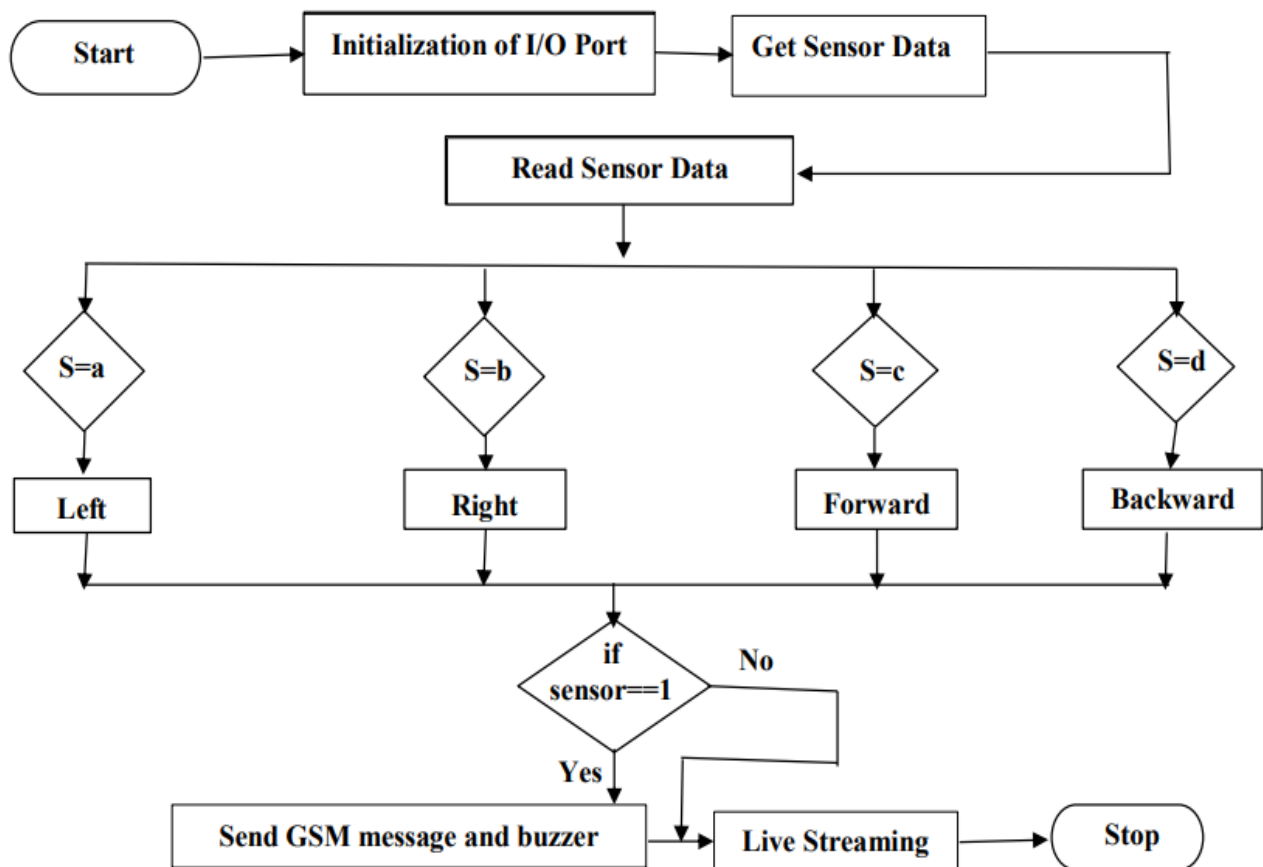

Fig. 10: System Flow Chart

4) Results and Discussions

Landmines can pose a huge threat to not only the potential victims, but are equally hazardous to the officials appointed for the diffusion of the landmine.

Atmega328 microcontroller serves as the 'brain' of the entire system. The proposed system as a whole can be categorized into three subsystems:

- 1) Mobility system
- 2) Tracking system
- 3) Surveillance system

As the name suggests, the mobility system is responsible for the swift and uninterrupted motion of the robotic vehicle. This subsystem mainly comprises of the motor driver and a couple of DC motors. The motor driver is interfaced to the Atmega328 microcontroller and the motors are connected to the rear left and right wheels of the robotic vehicle. All these components, all together are responsible for the motion of the robotics vehicle.

The tracking system crucially consists of the GPS module and a GSM module. After establishing a steady motion, the robotic vehicle is used to inspect the area of suspected threat. The Metal detector sensor, another part of this subsystem, once detects the presence of a landmine will trigger the GPS module and the module will send the geographical coordinates to the microcontroller which further activates the GSM module which is responsible for sending an "Alert" message to the authorities.

The surveillance system essentially uses a ESP32-CAM module. This module is a combination of an ESP microcontroller and a camera. This component can be connected to external communication devices like mobile or laptop through WIFI or Bluetooth connection. This system is responsible for the live surveillance (video streaming) of the surrounding environment which enhances the visibility of the operator.

A successful integration of all these subsystems can give rise a system which will be able to move freely, track accurately and ensure a clear view of the surroundings. Furthermore, the safety of the civilians as well military personnel.

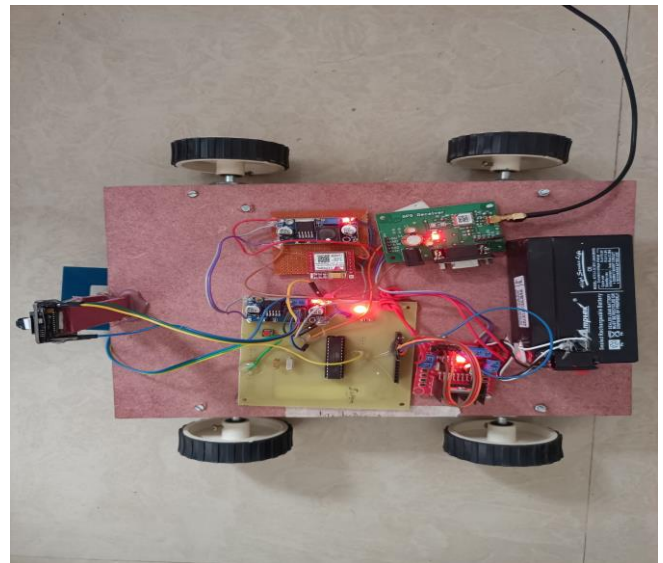

Fig. 11(a): Top view of Final Prototype

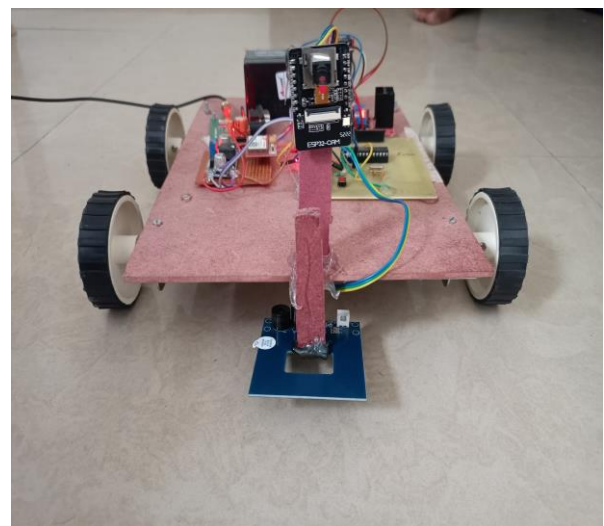

Fig. 11(b): Front view of Final Prototype

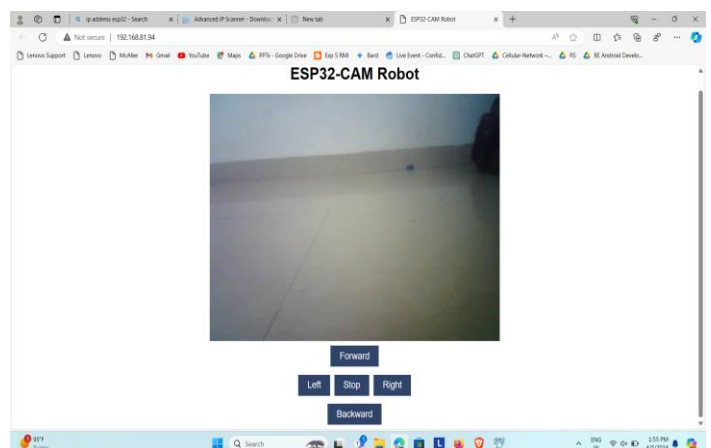

Fig. 12: Live Surveillance & Vehicle Controls

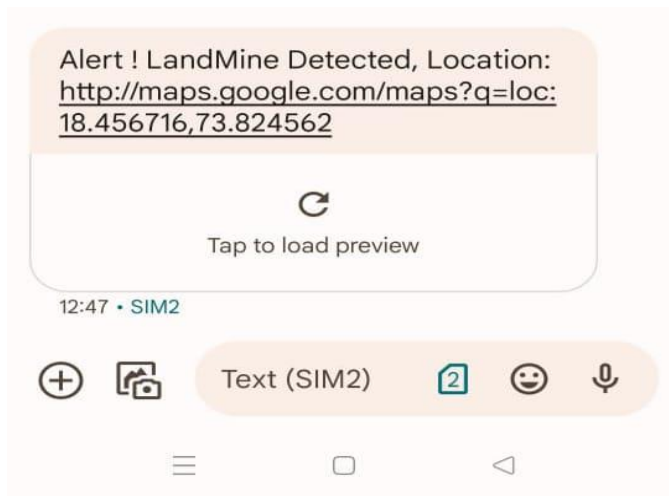

Fig. 13(a): Alert Message

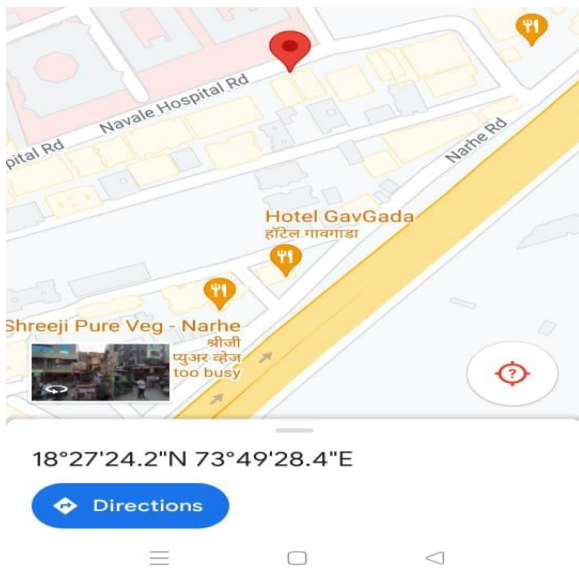

Fig. 13(b): Live Location

5) Applications

- Most essential application of Landmine detection robot is to clear the minefields and make the land safe for people to live and work.
- Landmine detection has military applications where it will help to protect the soldiers from landmine attacks and to clear routes for military vehicles.
- Security of sensitive areas and prevention of illegal crossing of borders can be ensured through landmine detection robots.

6) Conclusion

In conclusion, landmine discovery robots hold immense eventuality to revise the demining process. Advancements in detector technology, specifically hyperspectral imaging for enhanced environmental perception, and the development of independent capabilities promise to produce landmine discovery robots that aren't only more accurate and effective but also significantly safer for mortal deminers. Eventually, these advancements can pave the way for briskly, safer, and further cost-effective mine concurrence, eventually saving lives and contributing to a future free from the troubles of landmines.

References

- [1] Ibrahim A. Hameed, "Motion Planning for Autonomous Landmine Detection and Clearance Robots", In: International Workshop on Recent Advances in Robotics and Sensor Technology for Humanitarian Demining and Counter-IEDs (RST), October 2016
- [2] Girish Santosh Bagale, Abhishek Jire, "Design and Development of Landmine Detecting Robots", In: International Journal of Innovative Research in Science, Engineering and Technology (An ISO 3297: 2007 Certified Organization) Vol. 5, Issue 9, September 2016
- [3] Vrushali D. Pawar, Priyanka B. Patkare, Pooja A. Naik, Nikita B. Patil, Rohan A. Chaugule, "IoT Based Landmine Detection Robot With GPS System", In: Journal of Embedded Systems and Processing, April 12 2019
- [4] Vishnu Prakash, Pramod Sreedharan, "Landmine Detection Using A Mobile Robot", In: IEEE 9th Region 10 Humanitarian Technology Conference (R10-HTC), 2021