

Smart Vehicle Accident Detection System Using GSM and GPS

Sagar Y. Kumbhar¹, Rushikesh Chavan², Sudesh Kalokhe³, Rajvardhan Patil⁴.

¹Assistant Professor, E&TC Engineering Department, D. Y. Patil Technical Campus, Faculty Of Engineering And Faculty Of Management, Talsande, Kolhapur, Maharashtra, India.

^{2,3,4}Student, E&TC Engineering Department, D. Y. Patil Technical Campus, Faculty Of Engineering And Faculty Of Management, Talsande, Kolhapur, Maharashtra, India.

ABSTRACT - The Smart Vehicle Accident Detection System using GSM and GPS is a solution to solve the accident problems and human deaths caused by the delay in hospitality. This system includes GSM modules and GPS receivers, to detect the vehicle acceleration, movement in real-time. When the accident event occurs, system detects the occurrence of accident and through the GSM and GPS an emergency alerts are sent to the nearest hospital and the relatives. The combination of GSM and GPS technologies in this project provides a best way for improving road accidents and safety of human being.

KEYWORDS: GSM, GPS, Arduino, Piezoelectric Sensor, Real-time monitoring, Automatic Alerts, Emergency Services Integration.

I. INTRODUCTION

As our age advances, so does the use of vehicles. At the same time, the number of physical, financial, and environmental degradation of vehicles is increasing. In this regard, the number of vehicle accidents is on the rise, which can lead to the interest of safe driving and safety waves in the owner's body.

Vehicle accident detection systems are a very important topic, recently solved by accident recognition and instant artificial warning systems. Both GSM (Global System for Mobile Communication) and GPS (Global Positioning System) technologies are active in this system, so that vehicle position and accidents can be identified instantly.

Using GSM, the system can transfer accident information instantly and securely. The position of the vehicles can be identified during the GPS journey, which helps to immediately identify the accident situation to the emergency services or people or safety.

This paper is about how smart vehicle accident detection system enhances vehicle safety and helps people get instant status of accidents. As the use of the system increases, it can contribute significantly to improving social and economic conditions by helping to reduce the number of vehicle accidents.

This paper is going to describe the achievements of smart vehicle accident detection system and its

application, where safe, effective, and immediate use of communication tools will help in improving the safety of vehicles and reducing the number of accidents.

II. PROBLEM DEFINITION

When accident happen, nearby individuals play a crucial role in calling an ambulance for victims. However, this dependence becomes problematic when there is no one nearby or bystanders ignore the incident. Compounding the issue, ambulances face delays in reaching accident sites and hospital due to traffic, underscoring a flaw in the current manual system.

III. METHODOLOGY

The Prototype of this Accident Detection and information passing technique uses the following steps :

1. Piezoelectric sensor detect the occurrence of the accident.
2. Through the GSM and GPS the emergency alerts which includes exact longitude and latitude are send to the nearest hospital and relatives.
3. The message receiver number is pre stored in the GSM module
4. When ambulance driver receives the emergency alert he select the root of the accident through the switch module and sends alarm on crossovers present on that root for controlling traffic.

The above steps are used in Smart Vehicle Accident Detection System.

IV. LITERATURE SURVEY

The literature survey on smart vehicle accident detection systems utilizing GSM and GPS reveals significant advancements in enhancing road safety. The integration of Global System for Mobile Communication (GSM) and Global Positioning System (GPS) technologies has garnered attention for its potential to provide swift and accurate accident detection.

1. Study on the Issue of Fake Calls:

Analysis to solve the problem of artificial calls in a smart vehicle accident detection system.

Studies focusing on developing techniques to help detect false calls.

2. Analysis and Improvement of Traffic Issues:

Analysis of traffic problems arising from the use of smart vehicle accident detection systems.

Studies to help improve traffic problems by establishing accident-selecting techniques.

3. Literacy of Problems Related to the Accuracy of Accident Location and Solutions:

Issues related to the accuracy of displacement data in smart vehicle accident detection systems and their improvement proposals.

Considering all above the problems we have implemented a proposed system which covers all the above mentioned problems.

V. COMPONENTS

1. Centre tapped Bridge Rectifier:

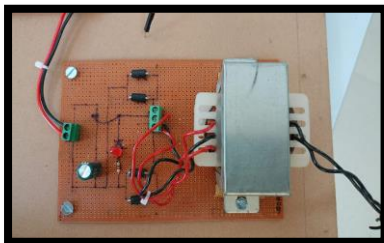

A centre-tapped bridge rectifier is a type of full wave rectifier circuit commonly used in power supply applications to convert alternating current (AC) into direct current (DC). It consists of four diodes arranged in a bridge configuration, with a centre-tapped transformer secondary winding providing the input AC voltage.

2.MPPT charge controller:

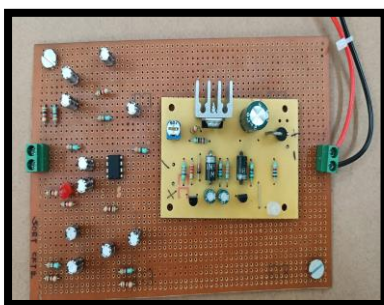

MPPT charge controllers play crucial role in maximizing the efficiency and performance of solar PV (photovoltaic) systems by continuously tracking and extracting the maximum power from the solar panels, thereby ensuring optimal energy harvest and battery charging.

3.GSM module in car:

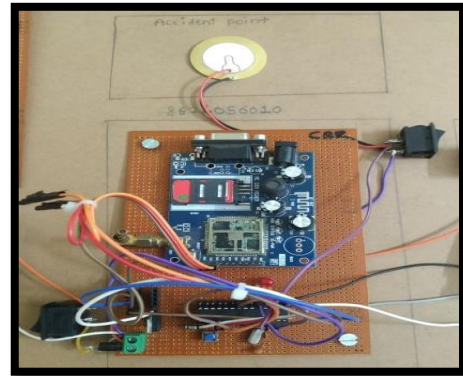

In the Smart Vehicle Accident Detection System, a GSM module is incorporated in the car to enhance the communication capabilities of the journey. In this module we set up communication with users. If the event of an accident occurs, the GSM module will immediately send an alert to the nearest hospital ambulance and relatives with information and details of the accident. The module uses the GSM network to transmit the exact location and details of the accident.

4.GSM module in Ambulance:

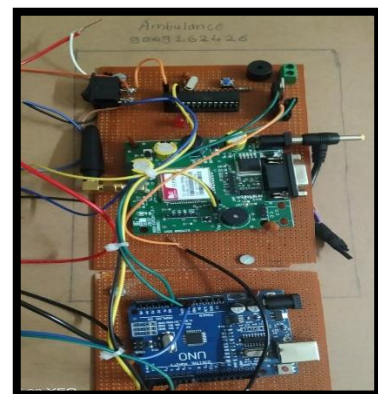

GSM modules in accident detection systems ensure safe and immediate communication and support with ambulances. The GSM module in the ambulance is linked with the car GSM module and receives the accident alerts from the smart vehicle system and communicates with the central monitoring system to provide vital information about the accident location. With this real-time data, ambulances can be dispatched promptly, reducing response times and helping us improve emergency medical services.

5. GSM module used in Crossovers:

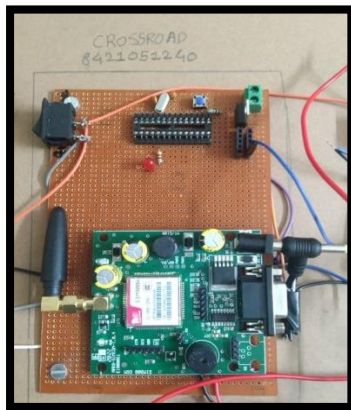

Crossovers, or points of intersection of different roads, are important points in road numbering. When ambulance driver receives the emergency alert he select the root of the accident through the switch module and sends alarm on crossovers present on that root for controlling traffic. We can have instant realizations of accidents or organizations at that point through the buzzer or alarm. This rapid communication improves the efficiency of traffic officials and the management of the accident scene during disasters and improves road safety.

6. Battery bank:

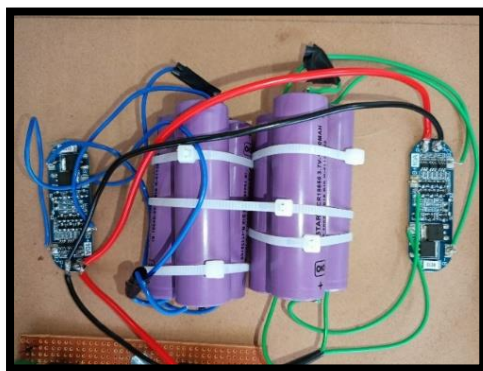

A 12 volt, 12 Ah battery bank consists of one or more 12 volt batteries connected together to provide a specific voltage and capacity suitable for this project, offering a balance between voltage, capacity and portability.

VI. BLOCK DIAGRAM



Fig: Proposed System

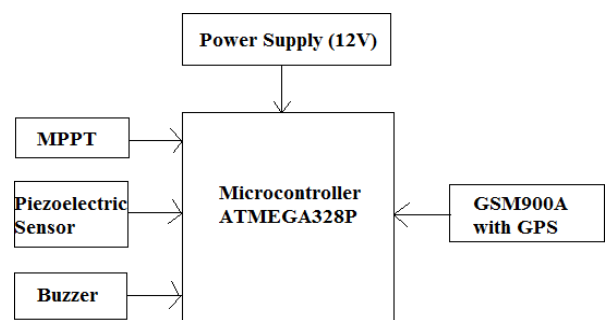
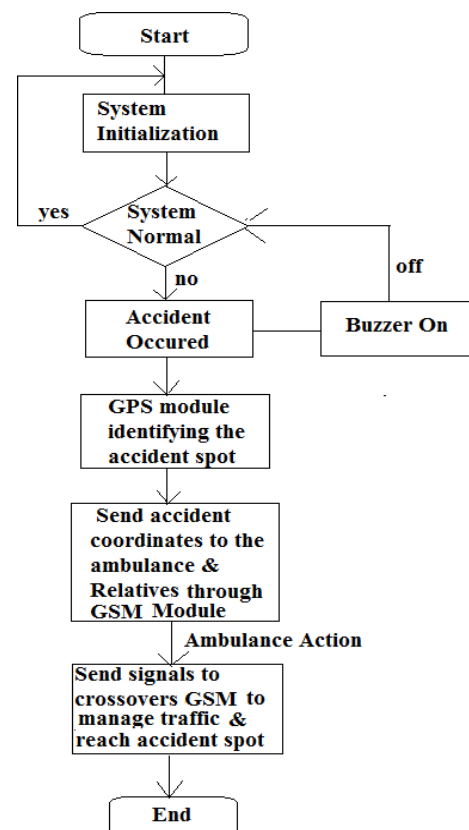

Fig: Proposed Hardware System

VII. FLOW CHART



VIII. WORKING

A GPS module used in a smart vehicle accident detection system is an important device. This module detects the location of the vehicle safely and accurately and instantly transmits the location, date, time and other important information of the accident to the emergency services and family members at the moment of the accident. So the vehicle can be relocated during the accident and the conditions can be monitored immediately.

The system is made up of three GSM and GPS for three specific transitions - accident location, ambulance, and crossover - together and separately. Promptly, observes and provides instructions to the Disaster Management Center in three shifts at a time.

When accident occurs, through the cars GSM module where GPS is connected to it will transmits the coordinates, time and date to the ambulance and family members at a time. After receiving the location of the accident spot ambulance driver will send the buzzer signal to that road where accident is happened to control the traffic and minimize the time to reach accident spot.

IX. HARDWARE OF PROJECT

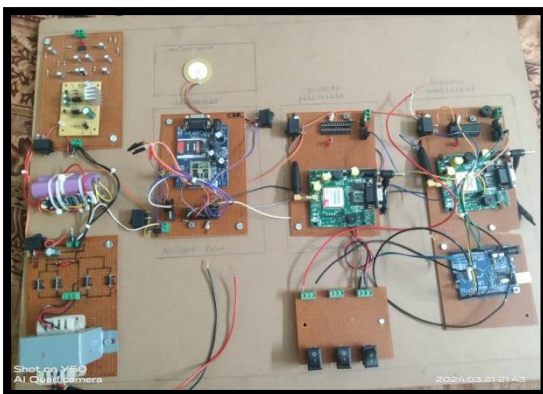

X. RESULT

Integrated GSM and GPS system in vehicles reports accident coordinates, time, and date to ambulance and family. Ambulance driver triggers buzzer signal for traffic control, reducing response time. Disaster Management Center receives real-time updates and instructions in three shifts. This system has provided an immediate version of organized disasters in vehicle accidents to individual and organized services, thereby providing safety and prompt assistance.

XI. FUTURE SCOPE

The system aims to create a vehicle under three specific conditions - accident location, ambulance, and

crossover companion and separately. It has a complete and lively management center with three shiftary monitoring and monitoring. When an accident occurs, the car's GSM module has GPS associated so it will send the reference information (coordinates), time and date of the accident location to the ambulance and family members at once. After receiving the reference information of the accident location, the ambulance driver sends the reference information to the accident location and sends a buzzer signal to the road to control the traffic and helps to reduce the communication time.

This safety and emergency management system is a new first in human safety and repair management. For our future endeavors, we are passionate about helping improve the health and safety of travelers by removing space from their bedside tables. The nature of the security system and emergency management center, along with fiber and structural considerations, can help improve its performance by replacing

its upgrades and new changes in the latest technologies in the fiber format. With the participation of skeletal and fiber thinking, the security system can be updated by updating the latest technologies that help in expanding and demonstrating the system.

XII. ADVANTAGES

- Rapid Emergency Response
- Enhanced Safety for Drivers and Passengers
- Real-Time Location Information
- Automated Communication with Relatives
- Efficient Traffic Management
- Reduced Response Time for Emergency Medical Services
- Minimized Severity of Injuries
- Peace of Mind for Relatives
- Simple and Reliable Design
- Easy to operate

XIII. CONCLUSION

Smart vehicle accident detection system is an important, positive and innovative solution for our prosperity and safety. By using this system, your vehicle can get immediate assistance after an accident and help in exhibiting organized services. A smart vehicle accident detection system has contributed positively to your safety and the welfare of your family. This system ensures safe

operation of the vehicle and provides immediate inspection of the vehicles involved in the accident and experienced emergency services. The smart vehicle accident detection system has improved the vehicle safety level and demonstrated improved services for organized vehicle inspection of accidents. These findings contribute to research and development research literacy that formalizes the field of vehicle safety and disaster services. With this system in a positive environment, your vehicle is safe and your relationship is safe.

XIV. REFERENCES

1. Yap, W. S., & Wong, Y. D. (2015). Intelligent transportation systems: a review. *IET Intelligent Transport Systems*, 9(2), 182-191.
2. Hu, W., Chen, W., & Du, D. H. C. (2012). The integration of GPS and GSM for real-time vehicle tracking. *International Journal of Information Technology and Computer Science*, 4(8), 36-43.
3. Amini, A., Amini, A., & Ghaemi, Z. (2018). A review on the application of geographic information systems (GIS) in disaster management. *Geoenvironmental Disasters*, 5(1), 11.
4. Gupta, A., & Sharma, A. (2015). Smart ambulance monitoring and controlling system using IoT. *International Journal of Computer Applications*, 126(1), 35-39.
5. Viti, F., Colajanni, M., & Romano, S. P. (2013). An ITS architecture for emergency management. *Computer Communications*, 36(4), 433-444.
6. Zeadally, S., Hunt, R., Chen, Y. S., & Irwin, A. (2012). Vehicular ad hoc networks (VANETs): status, results, and challenges. *Telecommunication Systems*, 50(4), 217-241.
7. Khattak, A. M., Jabbar, S., Naeem, M., & Khan, A. A. (2016). Real-time data communication in vehicular ad-hoc networks: a review. *Wireless Networks*, 22(2), 395-411.
8. Kemp, C., & Stroud, J. (2019). The application of GPS technology in emergency response. *Journal of Spatial Science*, 64(1), 67-78.
9. Talukder, J., & Hakak, S. (2018). A human-centric design approach for disaster management information systems.