

Development of Drawbridge in Train for Physically Disabled People

Manoj U¹, Ganeshachari B², Chithra Y³, Manojkumar H.M⁴,
Dr. Annapoorna T. L⁵, Dr. Batluri Tilak Chandra⁶

1,2,3,4 8th Semester, Department of Mechanical Engineering, 8th semester students, Sri Siddhartha Institute of Technology, Tumkur – 572105

5, 6 Assistant Professor, Department of Mechanical Engineering, Sri Siddhartha Institute of Technology, Tumkur – 572105

Abstract - Passengers who are elderly, young, or crippled find it difficult to get aboard the train with their bags. Generally speaking, the train bogie's steps are substantially higher than the station platforms. Our decision was made to create a sliding ramp for trains, specifically for low-floor trains. The ramp needed to be highly capable of withstanding heavy loads and function autonomously and rapidly. A motor and a sensor are used to accomplish actuator. Three primary structural components make up the ramp, along with a few auxiliary parts that facilitate the movement of the major structural components. Standing in front of the IR sensor is the passenger when the door is open. The Arduino Uno will receive the signals from the IR sensor. The ramp expands self-sufficiently and waits for people to board the train before returning to its initial position on its own after a certain amount of time. It is positioned beneath the door to enable the ramp to be extended from its retracted position. The motors within the housing spin the pinion on the rack, causing the second plate to glide forward. When it comes out of the second plate, the first plate will go through the same procedure. The only differentiation in the mechanism, however, is that in the first plate motion, the rack moves linearly and the motor or pinion is fixed, but in the second plate motion, the rack is stationary and the motor hubs have linear motion. When both plates are fully extended, they should be at a particular angle with the ground. As a result, the second plate's tilt hinges are fitted. The motor will now revolve in the other direction and retract the plate using the same procedure.

Key Words: Rack and Pinion, Guide ways, DC Motor, and a Sensors

1. INTRODUCTION

There are certain low-floor light rail vehicles (LRVs) that employ bridge plates, which are moveable, mechanical wheelchair ramps. The Americans with Disabilities Act in the US mandates that the slope must be no more than one inch of rise for every twelve inches of length. The bridge plate extends from the vehicle to the platform, which must be raised to nearly the level of the floor of the vehicle to avoid the wheelchair having to travel an overly steep ramp. Rather than using a bridge, many low-floor buses use a ramp that is normally part of the floor but can be flipped out through the door (using a hinge at the door) onto the curb or street; in

this instance, the ramp is long enough to function as a true wheelchair ramp without being overly steep. Wheelchair accessibility is additionally provided by bridge plates on certain low-floor buses, which in this instance extend to the ground. Bridge plates can be manually deployed (by the driver or another crew member) or motorized, retractable ramps. First completed in 1996, the Siemens SD660 LRV passenger rail cars operated by TriMet (Portland, Oregon) were the first in North America to be outfitted with folding bridge plates. In the past, non-powered bridge plates fixed on station platforms were utilised in the newly finished Sacramento RT Light Rail system in 1987 to bridge the gap between an LRV's floor and a high-platform section at each station.

2. OBJECTIVES OF WORK

1. To facilitate board and deboarding for those with disabilities.
2. To reduce the need for outside assistance while moving a wheelchair inside the coach.
3. To create a well-thought-out system that includes an aluminum slant sheet that can easily provide a track for wheelchair mobility.
4. To implement rack and pinion technology with IR sensor in an automated ramp system for board and getting off on Indian trains.

3. METHODOLOGY

Three primary structural pieces and a few auxiliary parts for these structural elements' movement will make up the ramp. When the door is open, passengers must stand in front of the IR sensor, which sends signals to the Arduino Uno to cause the ramp to automatically expand and wait for people to board the train. After a short while, the ramp returns to its initial position the major body, second plate, and first plate are these three sections. The first and second moveable plates of the ramp can both slides linearly inside the main body. One part of the main and second plates is the rack and pinion system that moves the plates one and two. To ensure that the plates move smoothly; guidelines are included. the main plate to which the secondary plate is fastened. The second plate slides within the main body of the rack while the pinion, coupled to the motor, moves. The rack remains

stationary during this process. For the purpose of moving the first plate, the motor is situated in the middle of the main body. The first plate slides easily into the second because of the guideways, and it has a rack at its right end that is hooked to the pinion of the motor. When the motor starts to spin the stationary pinion, the rack will move linearly as a result. The first plate will therefore advance.



Fig 1: Handicap persons boarding the train

When a passenger with a disability joins the train through an open door, an IR sensor will detect their presence and automatically extend and retract the ramp. The sensor located next to the door. The train will automatically reverse course after stopping and ramping down to the station level for a while. It is where the ramp is moved to expand from its retracted position. To move the second plate ahead, motors housed within the housing turn the rack's pinion. The first plate will experience the same thing as it begins to emerge from the second plate. However, the sole distinction in the mechanism is that in the case of the first plate motion, the motor or pinion is stationary and the rack has linear motion, whereas in the case of the second plate motion, the rack is stationary and the motor hub has linear motion. Both of the plates should be at a certain angle with the ground when they are fully stretched. Thus, hinges are installed on the second plate for this tilt. Now, in order to retract the plate, the motor will rotate in the other direction, using the same procedure. IR sensor components were also provided.

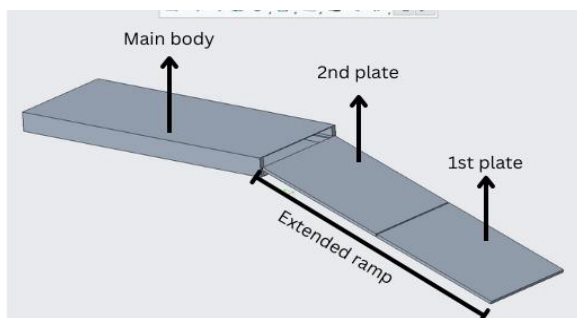

Fig 2: Parts of the draw bridge

The first plate of the assembly is installed into the second plate. With linear motion within the second plate, the first plate is also mobile. With the aid of a rack and pinion mechanism housed inside the second plate, the first plate advances. This rack has a moving pinion and a fixed rack.

The second plate was installed within the assembly's main body. Within the main body, the second plate is moveable and has linear motion. With the aid of a rack and pinion mechanism housed inside the primary plate, the second plate advances. Here the rack is stationary & pinion is moving.

The primary plate represents the entire Assembly's supporting framework. The primary plate, which is attached to the lowest portion of the low floor bus door, remains motionless. Holding the second plate of our construction with it helps. The rack and pinion mechanism is located in the main plate. For the second plate to move linearly and smoothly, guideways are also included in the primary plate.



Fig 3: Rack & Pinion Mechanism

A rack and pinion mechanism is a kind of linear actuator in which rotational motion is converted to linear motion by means of a circular gear (called the pinion) interacting with a linear gear (called the rack). The ramp is extended and retracted in this example using a rack and pinion system.

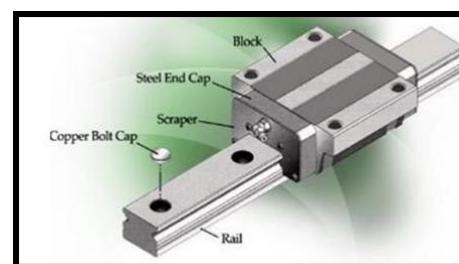

Fig 4: Guideways

The wheelchair ramp's smooth movement is made possible by linear guides. These allow the first plate to gently glide within the second plate and the second plate inside the main body.

Electrical energy is typically converted into mechanical energy using motors. In order to move the plates both

forward and backward, a motor is necessary to provide the pinion with rotating motion. Here, bidirectional motion was achieved using the servomotor.

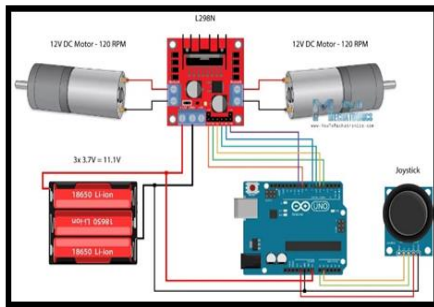

Fig 5: Motor driver

An amplifier or power module that joins a controller and a DC motor is called a DC motor driver. It transforms the step and direction input from the controller into currents and voltages that the motor can use. The voltage, current, directionality, and protection required to effectively operate robotic components or devices must be provided by the motor driver. DC motors are electromechanical devices that run an electric current through a shaft to rotate it. Their ability to spin in both forward and backward directions is helpful in a variety of situations. A DC motor can be used for applications that need variable speeds since it can change its speed by adjusting the supplied voltage or current. DC motors are crucial for a variety of applications, such as locomotives, rolling mills, steel mills, and lifts. Here are some pointers for selecting between a DC gear motor and a DC motor: Calculate your voltage, torque, and speed. Think about size for increased torque, use brush DC gear motors.

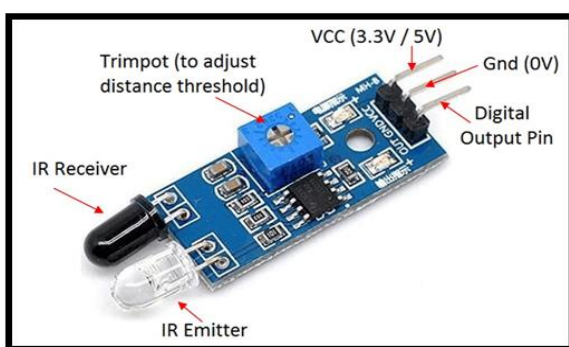

Fig 6: IR sensor

An apparatus that recognizes and interprets infrared (IR) signals is known as an IR sensor board or IR sensor module. Typically, it has a signal amplifier, a demodulator circuit, and an IR receiver LED. While the signal amplifier and demodulator circuits process and amplify the IR signals, respectively, the IR receiver LED detects the signals. Photodiodes that detect infrared light are called infrared

sensors. The resistances and output voltages of the photodiode fluctuate in response to the intensity of infrared light as it reaches it. Infrared sensors are able to monitor an object's temperature and detect movement. They are utilized in a wide range of fields and daily activities, including consumer electronics, automation systems, and robots.

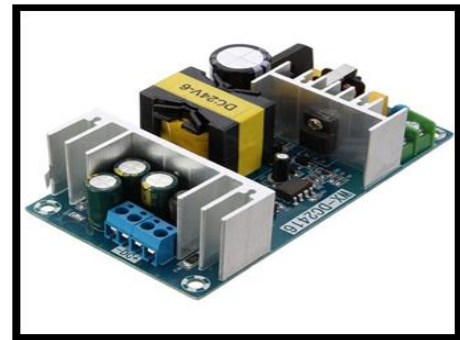

Fig 7: power supply board

An electrical device that provides power to linked components is called a power supply board. In order to power the load, it transforms electric current from a source into the proper voltage, current, and frequency. Protection against short circuit, overvoltage, overcurrent, undervoltage, and overtemperature may be present on power supply boards.

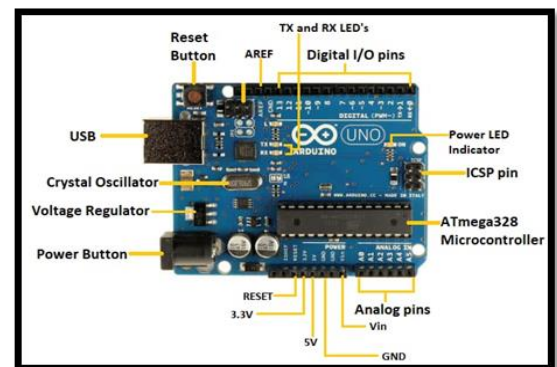

Fig 8: Arduino Uno

A well-known microcontroller board built on the ATmega328P chip is the Arduino Uno. The reason for its popularity in hobbyist projects and prototyping is its broad community support, simplicity, and adaptability. In addition to six analogue inputs, a USB port, a power connector, and an ICSP header for programming, it features fourteen digital input/output pins. It works well for both novice and expert makers to create a variety of electrical projects.

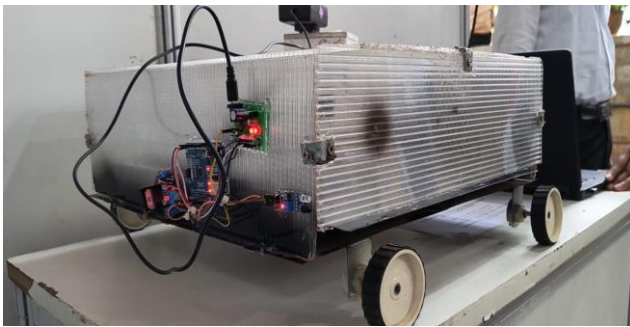

Fig 9: Ramp at rest position (prototype)

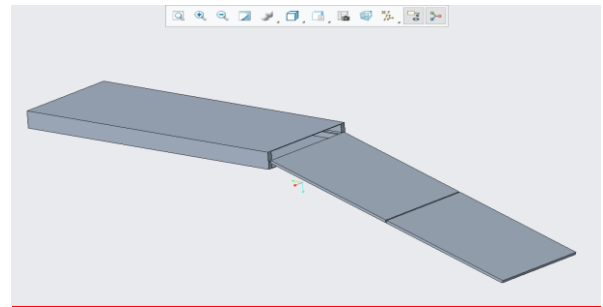

Fig 11: 3D CAD model

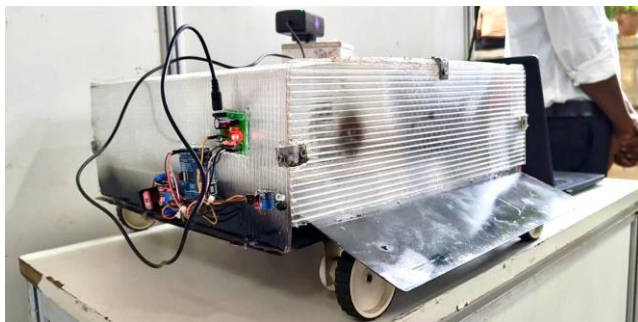

Fig 10: Ramp at extended position (prototype)

Three primary structural pieces and a few auxiliary parts for these structural elements' movement will make up the ramp. These three parts, which are the first plate, second plate, and major body. The ramp's first and second plates are movable parts that may both glide linearly within the main body. The rack and pinion mechanism that moves the first and second plates is a component of both the primary and second plates. There are guideways to ensure that the plates slide smoothly. The pinion is installed on the motor, which is encased in a housing that is fastened to the bar within the main plate and hinged to the second plate, in order to move the second plate. Regarding the second sliding

plate located in the main body, the rack is fixed, and the pinion connected to the motor is moving. The motor is placed at the front right end of the second plate to drive the motion of the first plate. Because of the guideways, the first plate moves smoothly into the second, and it has a rack attached to its right end that is connected to the motor's pinion. Thus, the rack will move linearly when the motor begins to rotate the stationary pinion. Thus, the first plate will move ahead.

When a passenger with a disability joins the train through an open door, an infrared sensor in front of the rail door detects their presence, causing the ramp to automatically extend and retract. the sensor that is positioned next to the door. The train will automatically reverse course after stopping and ramping on a level surface for a while.

3D CAD MODEL IN CREO PARAMETRIC

4. ANALYTICAL VAULES

The choice of materials is Popular aluminum alloy 6061 is renowned for having exceptional strength, weldability, and corrosion resistant qualities. Aluminum makes up the majority of it, with silicon and magnesium serving as the main alloying components. Because of its excellent strength-to-weight ratio and adaptability, alloy 6061 is utilized extensively in a variety of sectors, including aerospace, automotive, marine, and structural applications. It's widely utilised in the building of structural elements including beams, frames, and panels as well as in the production of bicycle frames, car parts, and maritime equipment.

For aluminum alloy 6061, which is commonly used in structural applications, typical values are as follows:

Tensile yield stress: Around 276 MPa

Tensile ultimate stress: Around 310 MPa

Compressive ultimate stress: Around 310 MPa

Given Dimensions:

Length (L) = 2.2 m

Width (W) = 0.85 m

Force (F) = 980 N

Cross-sectional area (A): $A = \text{Length} \times \text{Width} = 2.2\text{m} \times 0.85\text{m} = 1.87\text{ m}^2$

Now, let's calculate stress (σ) in MPa:

1. Stress (σ) = Force (F) / Area (A) $980\text{ N} / 1.87\text{ m}^2 \sigma \approx 524.06\text{ kPa} = 0.52406\text{ MPa}$

Now, let's calculate displacement (δ) in mm:

1. Displacement (δ) = Strain (e) * Original length (L) $\delta = 7.59 \times 10^{-6} \times 2.2\text{ m} \delta \approx 0.01658\text{ mm}$

So, with these calculations:

Stress (σ) $\approx 0.52406\text{ MPa}$

Displacement (δ) $\approx 0.01658\text{ mm}$

Based on the given allowable stress of 200 MPa, the design is safe as the calculated stress is significantly lower.

5. FEA IN CREO

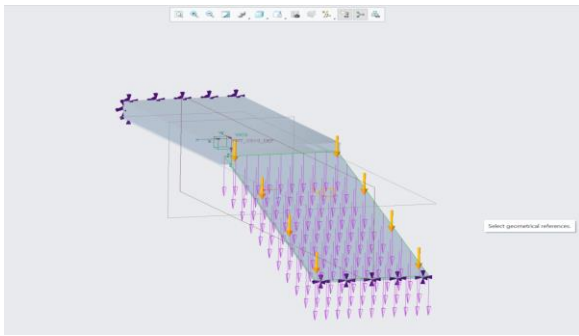

Fig 12: Force and constraints

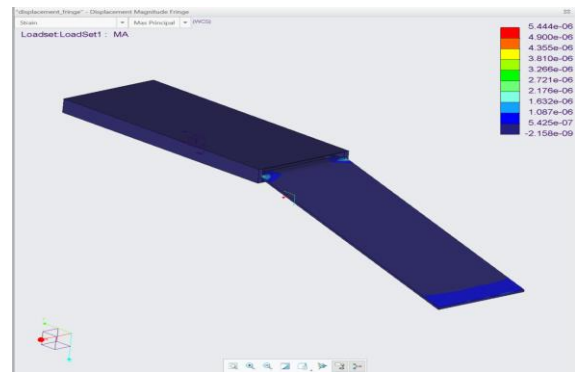

Fig 16: Value for maximum principle strain is 5.444e-06 MPa

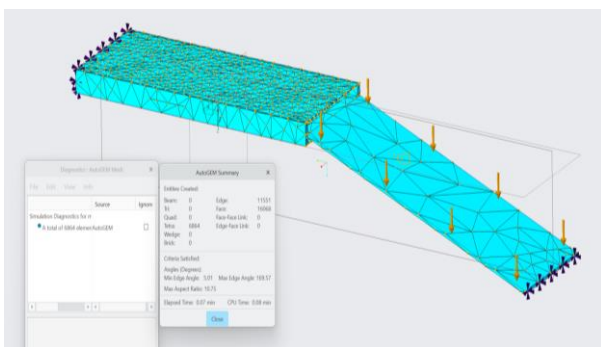

Fig 13: Meshed model

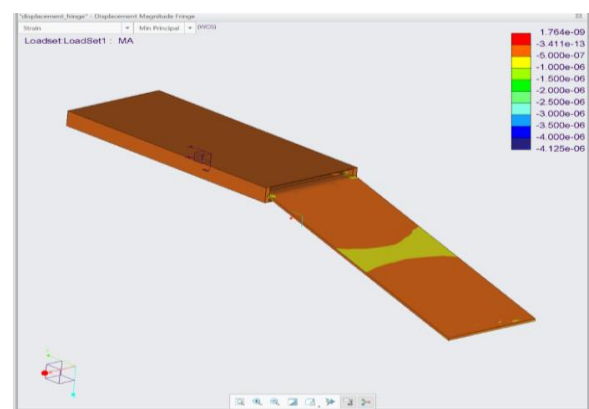

Fig 17: Value for minimum principle strain is 1.764e-09 Mpa

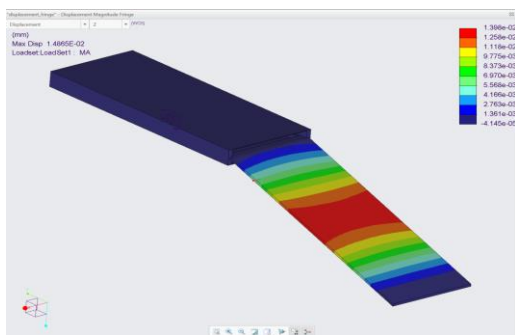

Fig 14: Maximum deformation obtained is 0.014865 mm

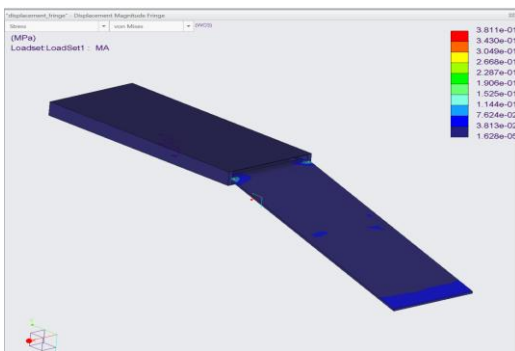

Fig 15: Maximum value for von-mises stress is 3.811e-01 Mpa

FEA RESULT

Sl. No.	Parameters Considered	Theoretical Results	FEA Results obtained in CREO V6
1	Load Applied	980 N	980 N
2	Total deformation	0.01658 mm	0.014865 mm
3	Maximum principle strain	7.59 e-6 Mpa	5.444e-06 Mpa
5	Maximum principle stress	0.52406 MPa	0.3811 MPa

Table :1Comparison of results

The above results show that the maximum deformation is 0.014865 mm, which is very small. So, the design of the system is safe.

6. CONCLUSION

"The structural study demonstrates that the ramp's design is safe and capable of supporting loads without experiencing significant deformation. The goals of the project are accomplished with the creation of an effective yet straightforward ramp system. In order to maintain a slant angle that provides proper ergonomics and comfort, there are no complicated mechanisms involved. The system is automated using rack and pinion in an industrial setting. Through this initiative, we can ensure that people with disabilities can easily transfer their wheelchairs onto trains."

ACKNOWLEDGEMENT

"We extend our sincere gratitude to the Karnataka State Council for Science and Technology (KSCST) for generously providing financial assistance, which was instrumental in successfully completing this project."

REFERENCES

[1] Aswin Santhosh: "An Automated Self-Adjusting Ramp to Entrain and Detrain For Differently Abled In Indian Railway System" International research journal of engineering and technology (irjet) eissn: 2395-0056volume: 07 Issue: 08 | Aug 2020

[2] Shital Pate: "Design of Automatic Ramp for Handicapped People" International research journal of engineering and technology (irjet) eissn: 2395-0056volume: 08 Issue: 05 | May 2021

[3] Jishnu v: "Semi automated adaptable ramp for differently abled to entrain and detrain" International research journal of engineering and technology (irjet) eissn: 2395-0056volume: 05 Issue: 05 | may-2018

[4] Abhishek gupta: "conceptual design to transfer handicapped people from railway Platform to their coaches", international journal of mechanical and production engineering Issn: 2320-2092, volume- 5, issue-9, sep.-2017

[5] R S Khurmi : "Design of machine elements-I", 2015

[6] Ibrahim, arish: "design and fabrication of ramp attachment for wheel chair", journal, Vol.7, no.7, pp.46- 48, 2014

[7] Storr, tim: "Design features of portable wheelchair ramps and their implications For curb and vehicle access",vol.41, no.3B, pp.443 - 452, 2008

[8] Design of an innovative retrofitted tricycle for a disabled person, 2007

[9] Vehicles for people with disabilities imported vehicles, modified vehicles, special purpose vehicles, Equipment and accessories,2004

[10] D. Kornack and P. Rakic, "Cell Proliferation without Neurogenesis in Adult Primate Neocortex," Science, vol. 294, Dec. 2001, pp. 2127-2130, doi:10.1126/science.1065467

[11] M. Young, The Technical Writer's Handbook. Mill Valley, CA: University Science, 1989