

# Analysis & Design of Foot Over Bridge Using Cold Formed Light Gauge Section

Omkar S. Komawar<sup>1</sup>, Prof. Sonali C. Patil<sup>2</sup>

<sup>1</sup>M. Tech Student, Structural and Construction Engineering Department, Ballarpur Institute of Technology, Maharashtra, India

<sup>2</sup>Assistant Professor, Structural and Construction Engineering Department, Ballarpur Institute of Technology, Maharashtra, India

\*\*\*

**Abstract** - A foot over bridge is a bridge designed for pedestrians. They are located across roads to let pedestrians cross safely without disturbing the traffic. Nowadays traffic is increasing day by day and the speed of vehicle. So, the pedestrian faces the problem to cross the road due to heavy traffic, hence there is need of safety crossings therefore the foot over bridge shall be constructed. In present practice hot rolled steel is used but cold formed steels are harder and stronger than hot rolled steel. Cold formed steel is a light gauge steel used to make construction processes smoother and products stronger. Cold formed steel is not heavy, having more strength and durability.

**Key Words:** Cold Formed Steel, Hot rolled steel, Light gauge steel.

## 1. INTRODUCTION

A pedestrian bridge is a structure designed specifically for pedestrians to cross over obstacles such as roads, rivers, railways, or other barriers safely and conveniently. These bridges can vary greatly in design, size, and materials used, depending on factors such as location, purpose, and budget.

Pedestrian bridges are essential components of urban planning and infrastructure, fostering pedestrian-friendly environments and encouraging sustainable modes of transportation. They play a crucial role in enhancing mobility, promoting physical activity, and creating inviting public spaces. Additionally, these bridges contribute to the overall safety of pedestrians by providing designated pathways away from vehicular traffic.

In this introduction, we will explore the diverse facets of pedestrian bridges, from their engineering and architectural significance to their impact on community well-being and connectivity. As integral elements of the built environment, pedestrian bridges exemplify the harmonious intersection of functionality, safety, and design, enriching the urban fabric and creating pathways for people to connect and explore their surroundings.



Fig. No. 1. Lattice Type Truss Pedestrian Bridge

### 1.1 Hot rolled steel sections

Hot-rolled steel sections refer to structural steel components that are shaped through the hot rolling process. This manufacturing method involves heating steel billets or slabs to high temperatures and passing them through rollers to achieve the desired shape. The hot rolling process allows for the production of a wide range of steel sections with various profiles and dimensions, making it a versatile and widely used method in the construction and manufacturing industries.

Here steel gets solidified but it is never allowed to cool down completely. The hot steel then passes through number of rollers that squeezes the material into desired cross-sectional shape & size. Rolling the steel while it is still hot allowing it to be deformed with no resulting loss in ductility, as would be in the case of cold formed steel sections during the rolling process; the member goes on increasing in length, which are cut to standard lengths which are subsequently cut to the length required for particular structure.

### 1.2. Cold formed steel sections

Cold-formed steel sections are structural members manufactured by cold working processes such as rolling or pressing from steel sheets or strips at room temperature. Unlike hot-rolled steel sections, which are formed while the steel is hot and ductile, cold-formed steel sections are

produced at ambient temperature, leading to different material properties and manufacturing techniques.

These sections offer several advantages, including high strength-to-weight ratio, dimensional accuracy, ease of fabrication, and recyclability.

### 1.3. Warren Truss

The "Warren truss" is a type of structural truss commonly used in engineering and architecture for supporting roofs, bridges, and other structures. It's named after James Warren, an Australian engineer who patented the design in 1848.

The Warren truss is characterized by its triangular configuration of members. It consists of a series of equilateral triangles, with diagonal members sloping alternately upwards and downwards from the apexes of the triangles. The horizontal members (often called top and bottom chords) provide support and distribute the load, while the diagonal members help to stabilize the structure and resist forces such as tension and compression.

## 2. OBJECTIVE OF THE STUDY

1. To access and compare the properties of Cold formed steel and Hot rolled steel sections.
2. To Model Pedestrian bridge using Staad Pro software by using Cold Formed and Hot rolled steel sections.

3. To Investigate the Structural performance of Cold Formed Steel by replacing Hot rolled steel.
4. To Identify the advantages and Disadvantages of Cold formed steel as compare to Hot rolled steel.
5. To give an Idea of Use of Cold formed Steel section to Engineers after calculating the strength and other properties of the same sections.

## 3. LOADING & SEISMIC PARAMETERS

Seismic parameter, (Nagpur Zone)

$$Z=0.10$$

Response reduction factor: 5

$$F_i=1$$

Wind calculations: as per IS: 875 (part 3)

$$V_z = V_b \cdot k_1 \cdot k_2 \cdot k_3$$

$$V_b = 44, k_1 = 1$$

Terrain category 3, class A;  $k_2 = 0.91, k_3 = 1$

Therefore,  $V_z = 44 \times 1 \times 0.91 \times 1$

$$= 40.04 \text{ m/s}$$

Wind pressure ( $P_z$ )

$$P_z = 0.6 V_z^2$$

$$= 0.6(40.02)^2$$

$$= 961.92 \text{ N/m}^2$$

## 3. APPLIED PROPERTIES TO THE MODEL

S. N.	HOT ROLLED STEEL SECTION			COLD FORMED SECTIONS		
	Sections	Total Length (m)	Total weight (Kg)	Sections	Total Length (m)	Total weight (Kg)
1	ISMC 300 D	82.40	5978	250CS80X5	82.4	1365
2	ISA 40 x 40 x 3	81.11	149	30LU15X1.25	73.8	20
3	ISA 55 x 55 x 8	28	180	100CU100X5	28	309
4	ISA 80 x 40 x 7	48.47	302	120CU50X3.15	38	196
5	ISA 100 x 75 x 10	68.63	887	100LUX100X6	46	409
6	ISA 100 x 100 x 15	169.16	3697	30LU15X1.6	177.2	20
7	ISA 120 x 120 x 10	46	840	100CU60X3.15	66	340
8	ISMC 250	35.11	1073	30CS15X1.25	35.11	25
	<b>TOTAL: -</b>	<b>558.88 m</b>	<b>13,106 kg</b>	<b>Total: -</b>	<b>546.41 m</b>	<b>2684 kg</b>

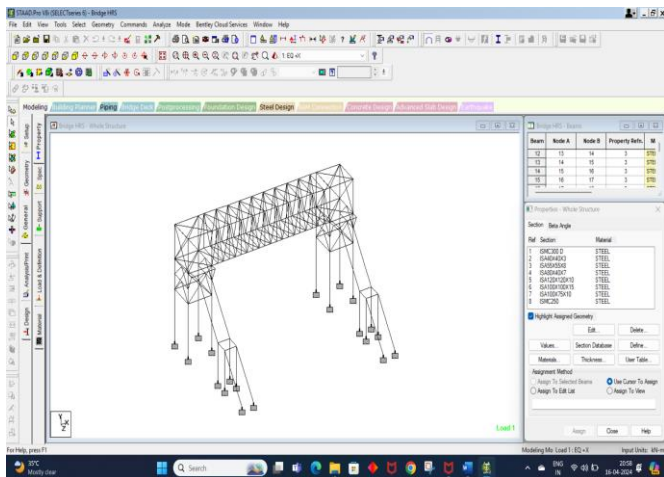

Fig. No. 2. HRS Properties Applied to Bridge

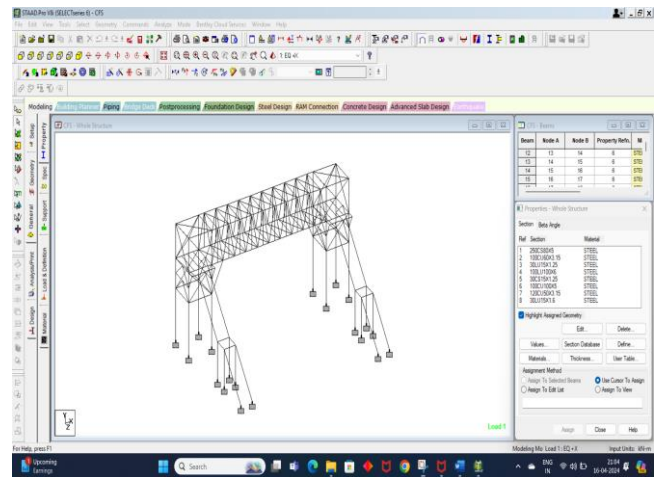

Fig. No. 3. CFS Properties Applied to Bridge

#### 4. RESULTS

Beam	Load combination	Hot rolled steel			Cold formed light gauge steel		
		Axial Force (KN)	Moment (KN-m)	Displacement (m)	Axial Force (KN)	Moment (KN-m)	Displacement (m)
2012	1.5(DL+LL)	$F_x = 7.723$	$M_y = 0.020$	0.029	$F_x = -8.223$	$M_y = 0.006$	0.225
2021	1.5(DL+LL)	$F_x = -48.296$	$M_y = 0.072$	-0.070	$F_x = -33.031$	$M_y = 0.005$	-0.077
2031	1.5(DL+LL)	$F_x = 8.251$	$M_y = 0.104$	0.058	$F_x = -8.461$	$M_y = 0.005$	0.220
78	1.5(DL+LL)	$F_x = 65.742$		-	$F_x = 5.580$		-

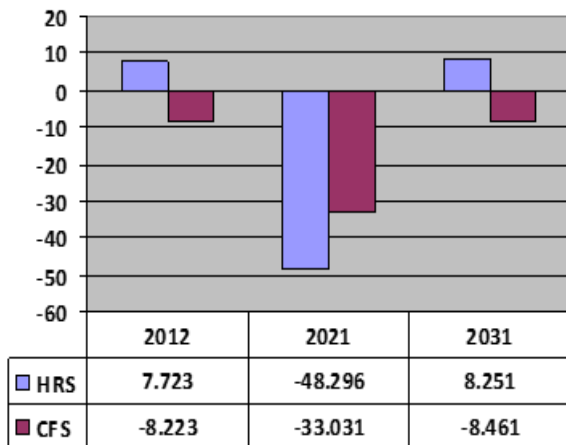

Chart No. 1 Axial Force

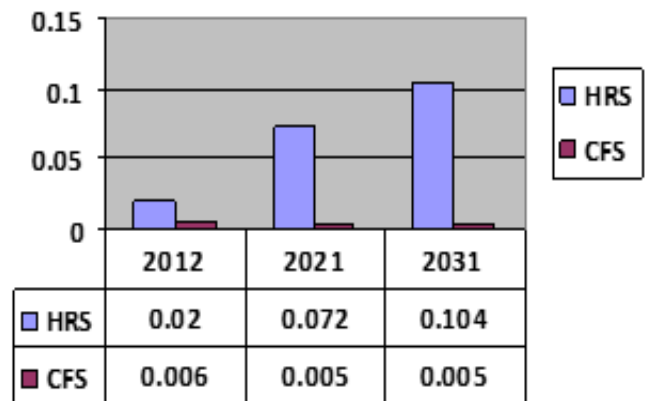

Chart No. 2 Moment ( $M_y$ )

**TIME HISTORY ANALYSIS**

➤ **HOT ROLLED STEEL BRIDGE**

Mode	Frequency (Cycle/sec)	Period
1	1.912	0.52301
2	2.722	0.36732
3	3.982	0.25116
4	4.543	0.18339
5	6.449	0.15507
6	8.841	0.11346

➤ **COLD FORMED STEEL BRIDGE**

Mode	Frequency (Cycle/sec)	Period
1	0.667	1.49853
2	0.667	1.49853
3	0.668	1.49797
4	0.668	1.49782
5	1.602	0.62426
6	1.602	0.62425

**5. CONCLUSIONS**

- From analysis it is observed that the maximum value for axial load & bending moment was greater in hot rolled steel structure as compared to cold formed light gauge steel structure.
- Weight of the structure vary according to the material and also the size of the sections used, from above results it is concluded that overall weight of the Foot over bridge using cold formed light gauge steel is lesser than overall weight of the foot over bridge using hot rolled steel.
- From the design and analysis of cold formed light gauge steel as a material it was concluded that the structure was more durable and economical as

compared to hot rolled steel material Hence it is more feasible to use.

- From the Results it seems that the Deflection/Displacement in the Beams in Hot rolled steel seems to be less as Compare to Cold formed steel

**6. REFERENCES**

- IS 800 (2007): General Construction in Steel-code of practice.
- ARE 1893 (2002) criteria for earthquake resistant design.
- IS 875 (part 3) wind load calculation.
- CD 353 "Design criteria for footbridges"
- "Plan of a steel foot over bridge in an urban railway station" (2017) [International journal of pure and applied mathematics] by S. Rajesh, Pradeep Saravanan. S.
- "Analysis and design of foot bridge" (2018) [International journal of Pure and Applied Mathematics] by M Kalpana, B. V Mohan Rao.
- "Analysis and design of footbridge connecting (2<sup>nd</sup> floors) of block A and block B of MIET Jammu" (2020) [International journal of engineering research and technology] by Akhil Sharma, Ashwani Kumar, Sunil Sharma, Arjun Singh chip, Rakesh Abrol
- "Analysis and Design of a Steel Foot Over-bridge with Tubular Sections using Sandro" (2020) [International Journal of Innovative Research in Engineering & Multidisciplinary Physical Sciences] by T. Prashanth, V. Gokul Nath.
- "Cold formed steel members and structures" [Journal of Constructional Steel Research] (Elsevier) by J. Rondal
- "A comparative study of pedestrian movement behavior over foot over bridges under similar land-use type" [World Conference on Transport Research]. (Elsevier) (2019) by Arunabha Banerjee, Akhilesh Kumar Maurya
- "Analysis of Cold Formed Steel Sections" (2020) [International Journal of Engineering Research & Technology] by Navyashree P M, Sowjanya G V, Dr. T. V. Mallesh
- "Analysis and Design of Foot Over Bridge" [International Journal for Research in Applied Science & Engineering Technology].(2023) by Dr. Vinayak Vaidya, Prasad Ugemuge, Gautam