

## Closed Loop Chopper controlled DC motor Drives

Asst.Professor R. Mahalakshmi<sup>1</sup>, H. Likhitha<sup>2</sup>, K. Gulshan kumar<sup>3</sup>, M. Anil kumar<sup>4</sup>

<sup>1</sup>Asst.Professor, Dept. of EEE, Visakha Institute of Engineering & Technology, A.P, India

<sup>2</sup>Student, Dept. of EEE, Visakha Institute of Engineering & Technology, A.P, India

<sup>3</sup>Student, Dept. of EEE, Visakha Institute of Engineering & Technology, A.P, India

<sup>4</sup>Student, Dept. of EEE, Visakha Institute of Engineering & Technology, A.P, India

\*\*\*

**Abstract** – Closed-loop chopper-controlled DC motor drives are sufficient in range of industrial and Consumer applications due to their precise speed and required control capabilities. This technology offers the advantages of DC motors with the precision of closed-loop control systems, resulting in efficient and reliable motor operation. To Enhance the performance of DC motors closed loop control systems have been developed and one of the key technologies is Chopper control. The chopper circuit is responsible for regulating the voltage supplied to the DC motor, it can operate in four quadrants, meaning that it can provide positive or negative voltage and current to the motor, allowing it to run in forward or reverse direction and to brake in regenerative mode. Speed controller (PI) and current controller plays a crucial role in maintaining desired motor behavior by adjusting the chopper pulse width modulation (PWM) signals.

**Key Words:** Choppers, Closed loop, Speed controller, DC motor drives, Four quadrant operation, DC power, wave forms

### 1.INTRODUCTION

Closed-loop chopper-controlled DC motors represent a sophisticated and faster approach to motor control, enabling precise and efficient results of motor speed and torque. Here separately excited dc motor drive is used because of its flexible control characteristics in which chopper is used to control the motor speed due to its less loss, high efficiency, lightweight, and quick response. The closed loop control of the chopper drive consists of two loops: an inner current loop and outer speed loop. The inner current loop regulates the armature current of the motor by comparing the actual current with the reference given current, which is derived from the outer speed loop. The speed loop controls the speed of the motor by comparing with the actual speed with the reference speed, which is usually set by the user or a higher-level controller. The speed loop controller can also adjust the reference current according to the load torque and the operating modes of the drive.

### 1.1 Choppers:

A Chopper is a high-speed semiconductor switch(S) that operates in an “on” or “off” state. Chopper circuit is a type of DC to DC converters. They change the fixed input DC voltage

to variable DC output voltage. Choppers are essential for efficient power control and signal application.

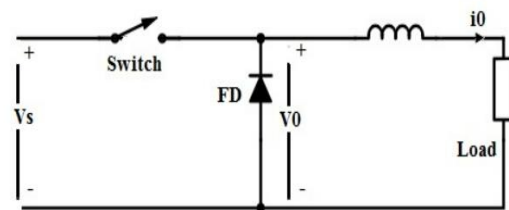

Fig.1 chopper diagram.

### 1.2 Classification of choppers:

#### 1.2.1 AC LINK CHOPPER:

In this classification of the chopper, the voltage inversion takes place. The DC voltage is converted into AC voltage with the help of inverter. Now this AC voltage is passed through a step-down or step-up transformers. The output from the transformers is again converted into DC by a rectifier.

#### 1.2.2 DC LINK CHOPPER:

DC chopper works on DC voltage. They can work as a step up and step-down transformers on DC voltage. They convert the steady constant DC voltage into a higher value or lower value based on their type. DC choppers are more efficient, speed and optimized devices.

### 1.3 Closed Loop Control System:

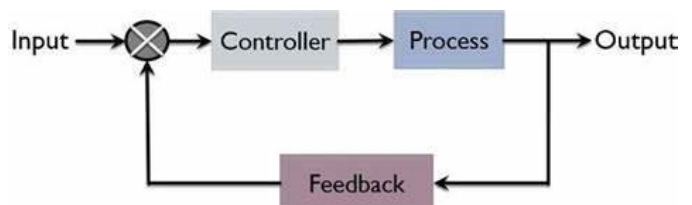

Fig.1.3 Closed Loop Control System

A closed-loop control system is also called it as feedback control system. It is automatically regulating a system to maintain a desired state or set point. The term “closed-loop” refers to the feedback loop established within the system. In

this loop, the output is continuously monitored and used to correct the system's performance. The objective of a closed-loop control system is to enhance stability, accuracy, and overall performance.

Error Detector Compares the desired output (set point) with the actual output and generates an error signal. It computes the error signal by comparing the input and feedback signals. Controller Processes the error signal and produces an actual signal to control the system. Feedback Elements is used to Provide information about the system's output (feedback signal). Power Plant Represents the physical process being controlled. The actual signal controls the power plant (process) to achieve the desired output.

### 1.4 Four Quadrant Chopper Operation:

A Four quadrants chopper is also called it as a class- E Chopper. A class-E chopper is a type of dc chopper that has the capability to operate in all four quadrants of output voltage and current. The output voltage and current can be positive or negative. A class-E chopper circuit is formed by the parallel combination of two class-C chopper circuits. This circuit consists of four switches (CH1-CH-4) and four diodes (D1, D2, D3, and D4).

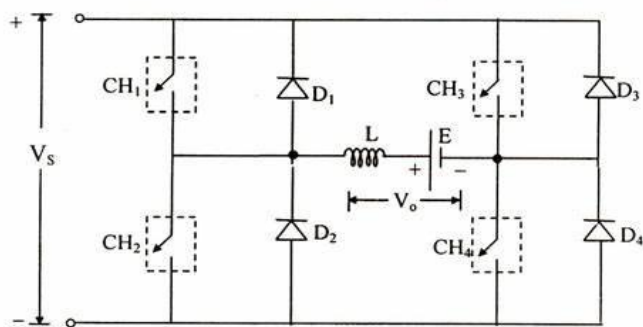
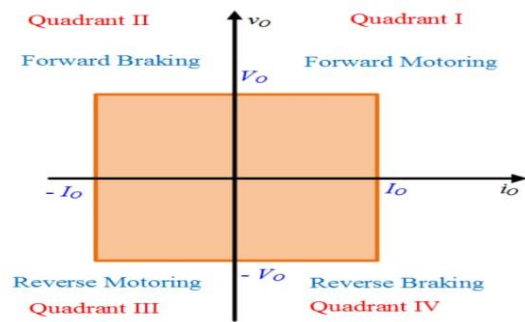

Fig 1.4 Four Quadrant chopper circuit

The operation of a class-E chopper in four quadrants is obtained by turning ON different switches and diodes combinations. Free Wheeling diode is connected in order to improve the wave form of load current and power factor of the circuit. It is also called as By-pass diode.

To obtain first quadrant operation, the circuit operates as a step-down chopper. The output voltage  $V_o$  and current  $I_o$  should be positive. The switches CH1 and CH4 are turned ON, the load gets connected across the source.

Thus, load voltage becomes equal to the source voltage, and the load current starts flowing in the circuit from source.



To obtain the second quadrant operation, the output voltage  $V_o$  should be positive, and output current  $I_o$  should be negative. The load will act as the dc source (generator). Here switch CH2 is operated while keeping other switches OFF.

To obtain third quadrant operation, output voltage  $V_o$  and current  $I_o$  should be negative. Load voltage and current should be negative. In order to operate a class-E chopper in the third quadrant, the polarity of load emf must be reversed.

To obtain the fourth quadrant operation, output voltage  $V_o$  should be negative, and output current  $I_o$  should be positive. To obtain the fourth quadrant operation CH4 is operated, thus load EMF drives current through S4, D2, and load.

### 1.5 BLOCK DIAGRAM:

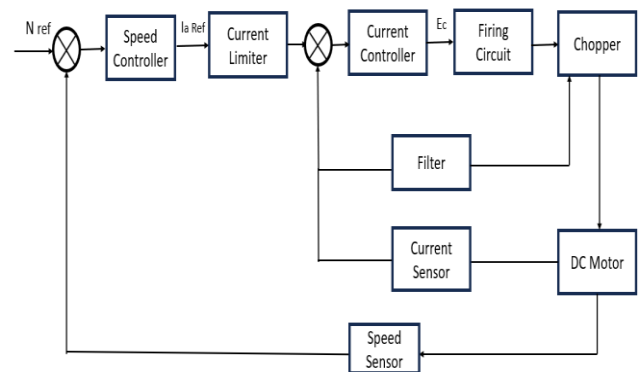

1.5 Block diagram of closed loop chopper-controlled DC motor drives.

From the above diagram, Speed Controller Compares the actual speed with the reference speed (\*) and adjusts the chopper control to maintain the desired speed level. Current Controller Maintains the motor current within the safe limits. It ensures that the motor current stays within predefined limits to protect the motor and the chopper. Firing circuit provide wave forms and duty ratio to control the chopper. Chopper Modulates the DC voltage to the motor. This circuit is responsible for controlling the amount of power supplied to the motor by chopping the DC voltage. It typically consists of switches (like MOSFETs or IGBTs) and diodes. Filter is

used to eliminate the unwanted disturbances or errors. Here Separately excited dc motor is used. Speed sensor checks the speed of the motor and current sensor measures the actual current of the motor.

From the diagram, it consists of two loops: inner current loop and an outer speed loop. Outer speed loop feedback line will generate the error signals at set point. Speed controller stabilizes the error signals and convert it to current signal the fed to current limiter. Current limiter generates reference current value and then given this signal to inner current loop. Inner current loop ensures the accurate current level and sudden change in torque demand and then fed to chopper. Here Chopper acts as a converter and regulates its voltage to motor terminals. Separately excited DC motor adjust its base speed and run at the given speed at set point. Speed sensor checks the speed of the motor as well as current sensor checks the motor current. At last, three parameters have been determined by using the displays.

**2. SIMULATION:**

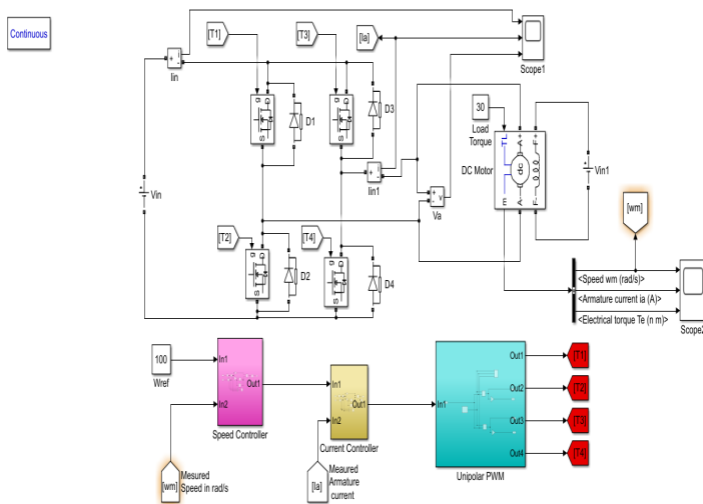

Fig 2: Simulation model of closed loop chopper-controlled DC motor drives

In the MATLAB simulation, this typically includes a DC motor, chopper, voltage and current measurements and the control system. Here MOSFET (Metal oxide semiconductor field effect transistor) is used as a chopper switch for the better performance, Faster Switching and low losses. MOSFET consists of four terminals that has drain, source, base and gate. Separately excited DC motor is used and additionally 240 V DC supply is given to the field. Model the armature, field, back EMF and Load torque. Armature terminals are connected to voltage and current measurements inputs to measure the instantaneous voltage and current. These outputs are connected to scopes to see the waveforms. Load torque should to connect to constant block in order to give the load torque values. Power Gui Should arrange at the top place for optimal performance.

In MATLAB simulation. Four Quadrant chopper-controlled operation is used. The chopper circuit is used to control the speed and regulate the voltage of the DC motor by varying the average voltage applied to it. Here Freewheeling diode is connected in parallel and it is used for smooth performance and improve the wave forms of load current. Also need to set up the appropriate interfaces between these components. The Drive features closed loop control with four quadrant operation. In a four-quadrant drive, all four quadrants of the speed-torque plane are operated. indicating forward/reverse and motoring/braking capabilities.

Once the model is set up with all the proper connections, set the time to analyze the connections. Once it is done, run the simulation with various input conditions and parameters to observe the system. This allows to analyze the performance of the closed-loop control system under different operating conditions. It's important to validate the simulation results against experimental data or known models to ensure that the simulation is done without errors. Finally, you may need to optimize the control parameters such as speed and current controllers and chopper settings to improve the performance of the system, such as reducing settling time or overshoot. The system response to these inputs is observed through waveforms.

**2.1 Output Results:**

Simulation output results of closed loop model of chopper controlled with DC motor is displayed below. The simulated output parameters are speed, load torque and armature current.

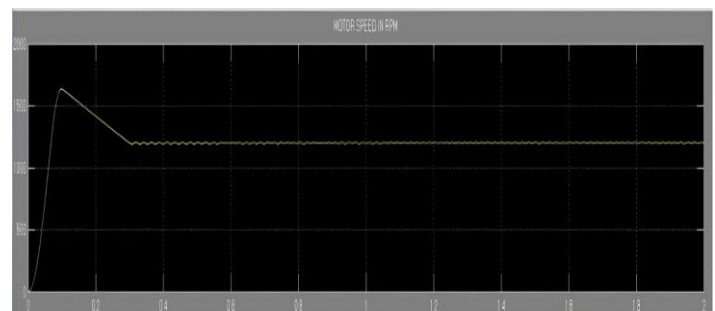

(a)Speed

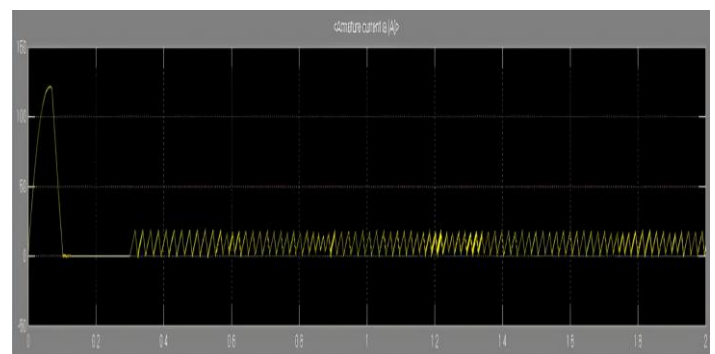

(b)Armature Current

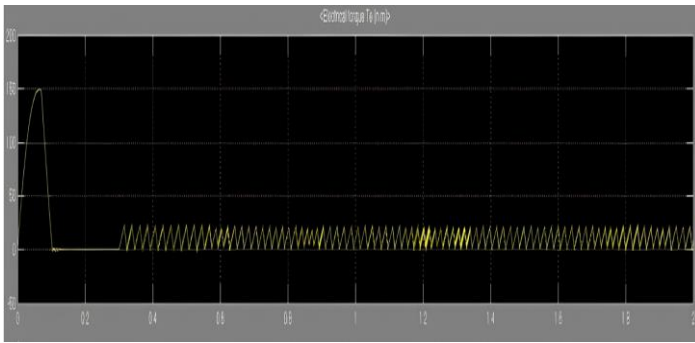

(c) Torque

Order PID Controllers, IEEE Transactions on Automatic Control, Vol. 52, No. 10, pp. 1964- 1969

- 5) Livinti Petru, Ghandour Mazen, "PWM Control of a DC Motor Used to Drive a Conveyor Belt", 25th DAAAM International Symposium on Intelligent Manufacturing and Automation, DAAAM 2014.

Speed wave form displays the actual speed of the motor. It should rise to match the reference speed and should maintain the desired level. Armature current waveform shows the current flowing through the motor's armature. In Closed loop system, the current should immediately reach the reference value set by the controller. This will reflect the motor's torque and speed characteristics. Torque waveform indicates the torque produced by the motor. It's reflected the motor load characteristics. Chopper control adjust the voltage to regulate the torque output. These three waveforms show how the motor speed, torque and armature current respond the changes in the output signals and how effectively the closed loop control system maintains the accurate performance.

### 3. CONCLUSIONS

In conclusion, Closed loop chopper controlled of DC Motor is successfully done. The speed of the DC motor has been successfully controlled by using chopper as converter. Current controller and speed controller plays a key role in this Closed loop operation. The Modeling of separately excited DC motor is done. The design of Four quadrant chopper circuit is done by choosing MOSFET as semiconductor switch. The MATLAB/SIMULINK model displayed good results under all conditions during simulation. The future of closed-loop chopper-controlled DC motor drives offer significant promise, with ongoing developments aimed at further improving their efficiency, reliability.

### REFERENCES

- 1) C.A. Monje et al. (2010): A Fractional-order Systems and Controls: Fundamentals and Applications, Springer.
- 2) J. Sabatier et al. (2015): Fractional Order Differentiation and Robust Control Design: CRONE, H-infinity and Motion Control, Springer.
- 3) M. Beschi, F. Padula & A. Visioli (2015): The Generalized Iso damping Approach for Robust Fractional PID Controllers Design, International Journal of Control, DOI: 10.1080/00207179.2015.1099076
- 4) SE. Hamamci (2007): An Algorithm for Stabilization of Fractional Order Time Delay Systems Using Fractional-