

# Blood group detection through finger print images using image processing (KNN)

G. Mounika<sup>1</sup>, M. Anusha<sup>2</sup>, D. Gopika<sup>3</sup>, B. Siva kumari<sup>4</sup>

*1<sup>st</sup> Author -B. Tech 4th Year ,Dept. of ECE, Bapatla Women's Engineering College , Bapatla*

*2<sup>nd</sup> Author- B. Tech 4th Year ,Dept. of ECE, Bapatla Women's Engineering College, Bapatla*

*3<sup>rd</sup> Author- B. Tech 4th Year ,Dept. of ECE, Bapatla Women's Engineering College, Bapatla*

*4<sup>th</sup> Author-Assistant professor ,Dept. of ECE, Bapatla Women's Engineering Coleege, Bapatla*

\*\*\*

**Abstract** - The fingerprint pattern is unchangeable and stays the same until the person passes away. The fingerprint pattern is unchangeable and stays the same until the person passes away. Fingerprint evidence is still thought to be the most important piece of evidence in cases involving events, even in legal courts. The black lines in a fingerprint image are called ridges, while the lighter areas in between are called valleys. The locations where ridges break are known as miniature points. Each human has a distinct minute pattern, and the likelihood of any two people being comparable is incredibly low—roughly one in 64 million. The minutiae pattern is different even for twins. Additionally distinct and unchanging from the moment of birth is the ridge pattern. Fingerprint analysis is also used to look into the blood group. Ridge frequency estimate is used in the fingerprint matching procedure. By using the K- Nearest Neighbor (KNN), the accuracy of the system increases when compared existing systems. Hence, by using this system accuracy increases.

**Key Words:** Finger print pattern, human identity, unique feature, ridge frequency, blood group, KNN (K-Nearest Neighbour), system accuracy, biometric identification, forensic analysis.

## 1.INTRODUCTION

The fingerprint pattern is the most dependable and distinctive aspect of a person's identify. The fingerprint pattern is unchangeable and stays the same until the person passes away. Every human has a unique minute pattern, with a very small probability of similarity—roughly one in 64 million—between them. The minutiae pattern is different even for twins. Additionally distinct and unchanging from the moment of birth is the ridge pattern. The blood bunch is an innate characteristic that remains constant throughout an individual's lifetime. It's also used in the analysis cycle to eradicate almost all infections. A blood test, which is obtained by infusing blood or by squeezing a needle on a finger, is necessary to determine the type of illness is mixed in with antibodies for the desired outcome; this may cost money. The International Society of Blood Transfusion Working Party, which was founded in 1980 in England, recognizes 43 blood group systems with 345 antigens for human red blood cells. The Working Party collaborates with

the International Blood Group Reference Laboratory to create a professional numerical terminology based on blood group genetics and is essential in guaranteeing patient safety. safety in blood transfusion. The key challenge for generating blood bunch forecast technique is non comprehensiveness of distinct examples of unique mark modalities. Examination throws almost no light on blood bunch forecast and various infections which accompanies maturing, especially if fingerprints are taken as a biometric methodology. There are three sorts of fingerprints plans found in fingers are Loops, Whorls, Arches are the most generally perceived from gathered informational index it nearly found about 65%.

## FINGERPRINT PATTERNS



**Fig1: Types of fingerprint patterns**

**Loop:** This is the most common fingerprint pattern, where ridges enter from one side, form a loop, and exit from the same side they entered. Loop patterns can be further classified as ulnar loops (ridge flow towards the little finger) or radial loops (ridge flow towards the thumb).

**Whorl:** In whorl the Ridges arranged in a circle or spiral make up whorl patterns. They can have a number of different subtypes, such as accidental whorls, double loops, central pocket loops, and plain whorls.

**Arch:** In arch Ridges that flow from one side of the fingerprint to the other, creating a pattern like waves, are what define arch patterns. Unlike loops and whorls, they lack prominent deltas, or triangular ridge formations. Based on the orientation and arrangement of the ridges, as well as the existence of particular characteristics like deltas and ridge counts, fingerprint patterns are examined and categorized.

These patterns are used by automated fingerprint recognition systems to generate distinct templates for every person, facilitating precise identification and verification in a range of settings, such as access control, border control, and law enforcement.

Blood group identification is essential for a number of medical operations, including organ transplants, blood transfusions, and forensic investigations. Blood typing has traditionally been done via serological techniques, which can be labor-intensive and need specific lab equipment. But as more sophisticated technology become available, there's a rising interest in creating automated, precise blood group prediction systems.

Type of finger print	Blood Group A		Blood Group B		Blood Group AB		Blood Group O	
	Rh+ve	Rh-ve	Rh+ve	Rh-ve	Rh+ve	Rh-ve	Rh+ve	Rh-ve
Loops	335 (63.2%)	24 (80%)	383 (62.79%)	23 (76.67%)	62 (68.87%)	0	385 (55.79%)	9 (45%)
Whorls	168 (31.7%)	3 (10%)	188 (30.82%)	6 (20%)	27 (30%)	0	246 (35.65%)	11 (55%)
Arches	27 (5.09%)	3 (10%)	39 (6.39%)	1 (3.33%)	1 (1.11%)	0	59 (8.6%)	0
Total	530	30	610	30	90	0	690	20

Fig2: RH Factor values of finger print patterns

Generally speaking, forward and reverse blood types can be distinguished by conventional serological testing. In particular, reverse typing is used to determine whether anti-A, anti-B, and anti-AB antibodies are present in serum or plasma, whereas forward typing identifies A and B antigens based on RBC agglutination by the particular antiserum and the intensity of agglutination. In clinical blood transfusion, the ABO antibody titer is also very important and is typically evaluated using several techniques such as the test tube method and the microcolumn gel card method. But because hemagglutination is the basis for all of these serological techniques, standardization is challenging and accuracy suffers as a result. It is usually required to perform an ABO test before receiving a blood transfusion. However, no one antiserum or method can ensure the identification of every uncommon, feeble, or mutant antigen. Furthermore, a few illnesses, like acute myeloid leukemia, can cause blood group antigen levels to drop.

1.1 VON NEUMANN ARCHITECTURE

The Princeton architecture, sometimes referred to as the Von Neumann architecture, is a hardware architecture that supports basic components. It permits the sequential use of a single memory. Since we use a very small amount of fast memory (cache) that is proximate to the processor, memory access times are still far below today's processing rates. An arithmetic unit, a program control unit, a single bus for memory access, and a single, shared memory for data and programs make up the Von Neumann architecture.

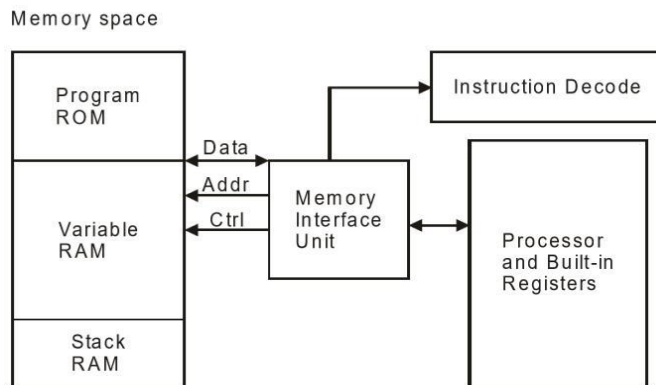

Fig3: Von neumann architecture

1.2 HARDWARE ARCHITECTURE

The Harvard architecture provides distinct signal buses and storage for data and instructions. With this architecture, the CPU houses all of the data storage; the instruction storage is not accessible as data. Internal data buses are used by computers to separate memory sections for program instructions and data, enabling simultaneous access to both. The CPU could not start up on its own; operators were required to load programs. It is not necessary to share attributes between the two memories in Harvard architecture.

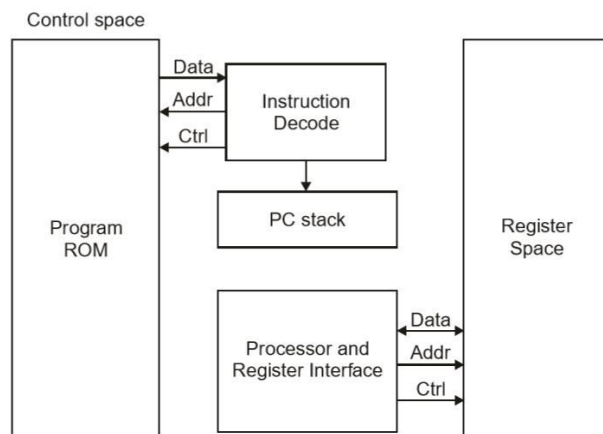
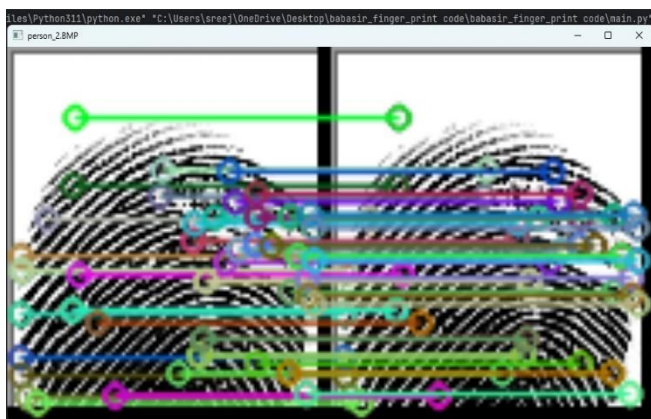

Fig4: Hardware architecture

This project aims to develop a K-Nearest Neighbour (KNN), model specifically designed for blood group prediction using fingerprint analysis. In order to accurately forecast blood types, the model will be trained to recognize and extract pertinent information from fingerprint photos. Train the system on a large dataset of labeled blood samples to ensure that the system can accurately predict the blood group samples. K-nearest neighbors (KNN) can be used in blood group detection by considering the characteristics of different blood types and comparing them to determine the closest match to an unknown sample based on its features. KNN works by finding the k nearest data points (blood

samples with known blood groups) to the unknown sample and assigning the most common blood group among those neighbors to the unknown sample. K-nearest neighbors (KNN) can be employed in blood group detection by first creating a dataset with features such as ABO blood type, Rh factor, and other relevant characteristics. Then, when a new blood sample needs to be classified, KNN calculates the distance between the features of the unknown sample and those of the samples in the dataset. The blood group of the unknown sample is then predicted based on the majority vote of the k nearest neighbors in the dataset. This method is particularly useful when dealing with datasets where the boundaries between blood groups are not well-defined.

### 3. RESULTS



**Fig5: Process of KNN in output**

In above image there is a trained image and sample image. Both images are compared by the KNN algorithm. By this image we can observe the KNN algorithm process that it can matching the ridges, loops, whorls, circles which are present in the fingerprint patterns.

After matching these k-nearest neighbours in the any of two fingerprint patterns it can detect the blood group and it gives the output like below Fig6

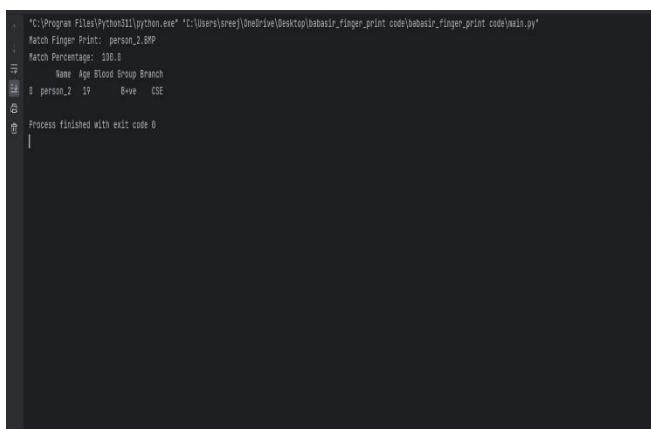

**Fig6: Output**

### 4. FUTURE SCOPE

The feature scope of this project is fingerprint scanner. It captures a digital image of the fingerprint. The captured image is called a live scan. The comparison is made between the valleys and ridges. Though your whole fingerprint is recorded, the computer takes only parts of the print to compare with others records.

### 5. CONCLUSIONS

Utilizing image processing techniques and the K-Nearest Neighbors (KNN) algorithm for blood group detection via fingerprints offers a promising avenue for non-invasive and efficient identification. Through this method, accurate blood group classification can be achieved, providing valuable insights for medical diagnostics and forensic investigations. Moreover, the integration of image processing with machine learning algorithms like KNN demonstrates the potential for innovative applications in biometric authentication and healthcare systems. Further research and refinement of these techniques could lead to practical implementations with significant real-world implications

### 6. REFERENCES

- 1) "Gupta, A., Agarwal, S., & Jain, R., et.al [3] investigates the use of machine learning algorithms, including Support Vector Machines (SVM) and Random Forests (RF), for blood group identification using fingerprint images" (2023)
- 2) "Verma, A., & Bhatt, V. et.al [1] provides an overview of automated blood group identification methods based on fingerprint analysis" use of machine learning algorithms (FEB 11,2022)
- 3) "Vijaykumar Patil N, D. R. Ingle; A Novel Approach to Predict Blood Group using Fingerprint Map Reading use of HFDU06 Scanner (Apr 02-04, 2021)"
- 4) Dr. D.Siva Sundhara Raja and J. Abinaya, "A Cost-Effective Method for Blood Group Detection Using Fingerprints", International Journal of Advance Study and Research Work, Volume 2, March 2019 .
- 5) A. Narkis Banu, V. Kalpana, "An Automatic System to Detect Human Blood Group of Many Individuals in a Parallel Manner using Image Processing", International Journal of Pure and Applied Mathematics, vol-118, pp. 3119-3127, 2018
- 6) G. Ravindran, T. Joby, M. Pravin, and P. Pandiyan, "Determination and Classification of Blood Types using Image Processing Techniques," International Journal of Computer Applications, vol. 157, no. 1, pp. 12-16, Jan. 2017.
- 7) Mouad. M.H.Ali, Vivek H. Mahale, Pravin Yannawar, and A. T. Gaikwad, "Fingerprint Recognition for Person Identification and Verification Based on Minutiae Matching",

2016 IEEE 6th International Conference on Advanced Computing, Feb. 2016.

8) Tejaswini H V, M S Mallikarjuna Swamy "Determination and Classification of Blood Types using Image Processing Techniques", ITS Transactions on Electrical and Electronics Engineering (ITSITEEE), Volume -2, pp. 2320 – 8945, 2014

9) Ferraz, Ana, Member, IEEE (2013), "Automatic system for determining of blood type using image processing technique", IEEE 3rd Portuguese Meeting in Bioengineering (ENBENG), pp. 20-23, Feb. 2013.

10) S. Pimenta, F. O. Soares, and G. Minas, "Development of an automatic electronic system to human blood typing," in Proc. IEEE Annu. Int. Conf. Eng. Med. Biol. Soc. (EMBC), Sep. 2012

## BIOGRAPHIES

### First Author



**G. Mounika** is a student of B. Tech in stream of Electronics and Communication engineering in Bapatla Women's engineering college, Bapatla, Andhra Pradesh, India. Here research in Image processing and KNN  
gollamownika@gmail.com

### Second Author



**M. Anusha** is a student of B. Tech in stream of Electronics and Communication engineering in Bapatla Women's engineering college, Bapatla, Andhra Pradesh, India. Here research in Image processing and KNN  
anushamalapati891@gmail.com

### Third Author



**D. Gopika** is a student of B. Tech in stream of Electronics and Communication engineering in Bapatla Women's engineering college, Bapatla, Andhra Pradesh, India. Here research in Image processing and KNN  
gopikadokku2002@gmail.com

### Fourth Author



**B. Siva Kumari (guide)**, M. Tech (PhD)  
Assistant Professor, Department of ECE  
Bapatla Women's Engineering College  
Affiliated to Acharya Nagarjuna University  
sivakumaribondalapati@gmail.com