

RC CAR CONTROL WITH HAND GESTURE AND OBSTACLE AVOIDANCE

¹ Dhirajkumar Pachling, ² Sarthak Kate, ³ Pratik Vidhate, ⁴ Diksha Kapse, ⁵ Nita Mahale

Department of Artificial Intelligence and Data Science, D Y Patil College Of Engineering, Akurdi, Pune, Maharashtra, India

Abstract

Hand Gesture

Gesture recognition is a game-changer, connecting the real world to the digital one. Our study introduces a new way to control cars using Arduino technology. By using an Arduino microcontroller, accelerometer, RF sender/receiver, and Bluetooth, we make car control automatic, eliminating the need for manual input. This system lets you control the car effortlessly with hand gestures, responding to your hand's movements and positions. This hands-free control not only makes driving easier but also improves how you interact with the vehicle. Our approach simplifies car control and opens up possibilities for more user-friendly interactions in areas like human-machine interfaces and the Internet of Things (IoT).

Obstacle Avoidance

We've enhanced safety by incorporating an automatic obstacle detection system into our design, preventing potential hazards. Our systems underwent testing in a lab-scale prototype to validate their efficiency, accuracy, and affordability. It's noteworthy that these proposed systems have the potential for future implementation on a larger scale under real-world conditions. This scalability holds promise for practical applications in areas such as automobiles and robotics, showcasing the adaptability and usefulness of our technology beyond the experimental stage.

Key Words: IoT (Internet of Things), Hand Gesture Recognition, Sensors, Motor Control, Arduino, Wireless Communication, Accelerometer

1. INTRODUCTION

The Internet of Things (IoT) has reshaped the capabilities of everyday objects, linking them to the internet and enabling autonomous responses to their surroundings. In critical tasks involving human safety, such as handling hazardous chemicals or managing heavy objects in factories, innovative solutions are imperative. A groundbreaking advancement in this realm is the emergence of hand-gestured cars, representing a paradigm shift in car control through gesture recognition.

The primary objective is to automate car control, eliminating manual input and allowing users to effortlessly control the vehicle through hand gestures. This hands-free

control not only simplifies the driving experience but also revolutionizes the interaction between humans and vehicles, contributing to the evolution of IoT.

The system goes beyond gesture-based control by incorporating an obstacle avoidance feature that enhances safety during operation. By automatically detecting obstacles, the technology mitigates potential hazards, significantly improving overall safety. Rigorous testing in a lab-scale prototype ensures the efficiency, accuracy, and affordability of these systems, paving the way for potential implementation on a larger scale in real-world.

The integration of hand-gestured control and obstacle avoidance features marks a crucial step in making the world safer and real-world challenges.

2. GOALS AND OBJECTIVES

1. Connect and Communicate with Physical Devices: IoT facilitates the communication between human and machine.

2. Faster and Smart Innovation: Speed is very crucial aspect of any tool. Because of use of sensors in IoT devices the output is given in a good speed with great accuracy.

3. Smart Sensing Capabilities: Sensors like accelerometer can sense very minute movement, for instance a little vibration, which humans cannot even recognize. It has tolerance just about 5 -10%. So the device works very precisely and can be used for such works where errors must be minimized.

4. Convenience: We can manifest very little movement on very large scale. In this way, we can do maximum work which requires minimum human energy.

3. SYSTEM ARCHITECTURE

A. Arduino UNO: This is the brain of the car and is installed with some code. The Uno is a microcontroller board based on the ATmega328P. It has 14 digital input/output pins (of which 6 can be used as PWM outputs), 6 analog inputs, a 16 MHz, 206 quartz crystal, a USB connection, a power jack, an ICSP header and a reset button. Arduino consists of both a physical programmable circuit board and a piece of software, or that runs on your computer, used to write and upload computer code to the physical board. Arduino Uno can sense the environment by receiving input from a variety of sensors

and can affect its surroundings by controlling lights, motors, and other actuators.

B. Accelerometer (ADXL335): An accelerometer is a one type of sensor and it gives an analog data while moving in the direction of X, Y and Z. These directions depend on the type of sensor. This sensor consists of arrow directions, if we tilt the sensor in one direction, then the data at the particular pin will change in the form of analog.

C. HT12E Encoder: The HT12E encoder are 12 bit encoders that is they have 8 address bits and 4 data bits. It encodes the 12-bit parallel data into serial for transmission through an RF transmitter.

D. HT12D Decoder: HT12D converts the serial input into parallel outputs. It decodes the serial addresses and data received by RF receiver into parallel data and sends them to output data pins. The serial input data is compared with the local addresses three times continuously and is only decoded when no error or unmatched codes are found. A valid transmission is indicated by a high signal at VT pin.

E. RF Module: An RF Transmitter and Receiver pair is used for wireless communication. The wireless data transmission is done using 434 MHz Radio Frequency signals that are modulated using Amplitude Shift Keying (ASK) Modulation technique.

F. L298 Driver: L 298 is a dual full bridge driver that has a capability to bear high voltage as well as high current. G. 150 RPM Motors: These are attached to the wheels of the car to give them power to move.

G. RF Transmitter: The RF transmitter transmits the encoded data wirelessly to a corresponding RF receiver on the car. This allows for remote communication between the hand-held device and the car.

H. Motor Driver : The decoded movement data is then sent to motor driver. The L298N is a dual H-bridge motor driver that controls the direction and speed of DC motors. Based on the decoded signals from the hand movements, the L298N motor driver adjusts the motor speed and direction accordingly.

I. Motor Control : The motors of the car are connected to the L298N motor driver. The adjustments made by the motor driver based on the hand movements cause the car's motors to move in a way that corresponds to the gestures or movements of the hand.

4. SYSTEM ARCHITECTURE

Hand-Gestures Recognition: The hand-gesture recognition system for controlling A car consists of two main components: The hand-gesture setup (Transmitter Circuit) and The Car setup (Receiver Circuit).

For the hand-gesture Setup: An Arduino Nano is used along with an MPU-6050 accelerometer and an RF transmitter. The MPU-6050 is connected to the Arduino Nano, with its SCL pin connected to analog pin A5, SDA to A4, Ground to GND, and VCC to the 5V pin of the Arduino Nano. The RF transmitter's DATA pin is connected to digital pin D8 of the Arduino Nano, with VCC connected to 5V and Ground to GND.

For the car Setup: An Arduino Uno is used along with an L293D motor module and an RF receiver. The digital pins A0-A13 of the L293D motor module are connected to the digital pins A0-A13 of the Arduino Uno, and the analog pins A0-A5 are connected to the analog pins A0-A5 of the Arduino Uno. The Vin pin of the L293D motor module is connected to Vin on the Arduino Uno, 3V to 3V, 5V to 5V, reset to reset, ground to GND, and AREF to AREF. The M1.1-M4.1 pins of the motor module are connected to the negative terminals of the motor, and the M1.2-M4.2 pins are connected to the positive terminals. The VCC pin of the RF receiver is connected to the VCC pin of the motor module, the DATA pin is connected to digital pin D2 of the motor module and Arduino Uno, and the Ground pin is connected to the GND port of the Arduino Uno.



Figure 1 Hand Gestured Controlled Car circuit layout

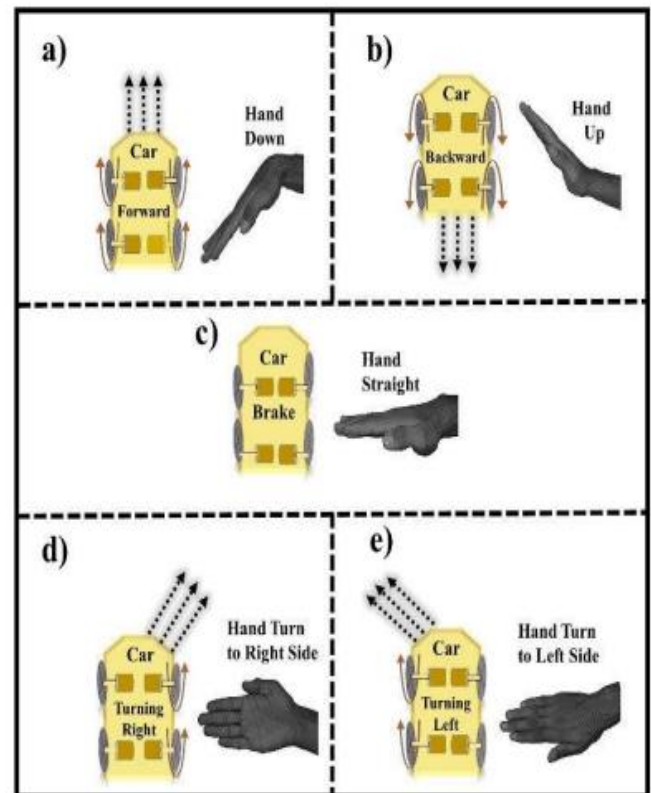
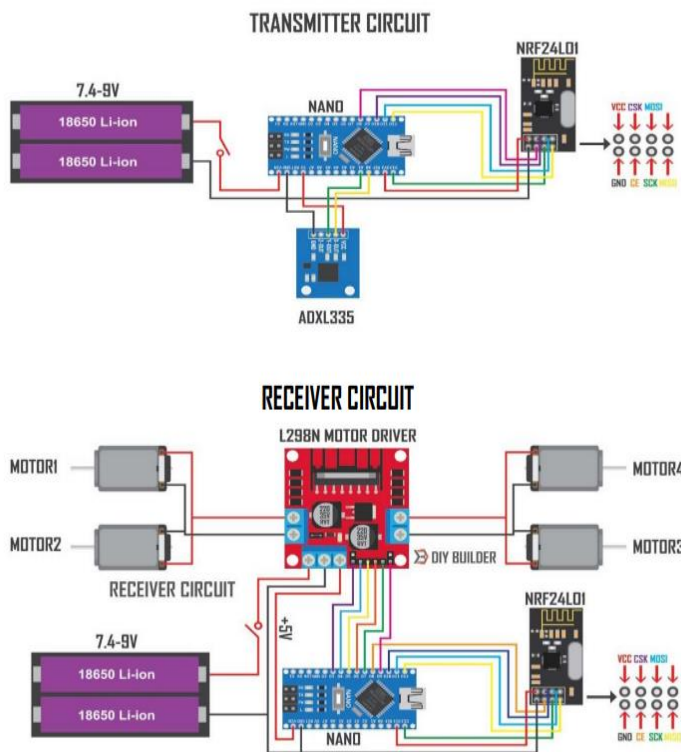

5. MOVEMENT OF MOTORS WITH HAND-GESTURE

The hand-gesture recognition system uses the accelerometer to capture hand movements, which are then processed by the application. The system defines minimum (Xrange) and maximum (Yrange) values to create ranges for each car function. When the received data falls within these ranges, the corresponding decision is made. This decision is sent to the microcontroller, which interprets the gesture and sends a signal to move the robot car accordingly. The car has four DC motors, one for each wheel, controlled by the L293D motor shield.

For movement gestures, tilting the hand downward signals forward movement, causing all four wheels to rotate forward (Figure a). Tilting upward signals backward movement, with all wheels rotating backward (Figure b). A straight hand signals the car to stop, halting all four wheels (Figure c). Tilting the hand right signals a right turn, rotating the right diagonal motors forward for a rightward movement (Figure d). Tilting left signals a left turn, rotating the left diagonal motors forward for leftward movement (Figure e).

The system distinguishes between right and left cutting turns based on the tilt of the hand. A cutting turn allows the car to change direction without slowing down. If the hand is tilted right, the car starts moving in a right circle direction, and if tilted left, it moves in a left circle direction. The accelerometer values for each gesture are distinct, ensuring the hand's position falls clearly within the defined ranges for each action, avoiding ambiguity.

6. IMPLEMENTATION

A. Circuit Connections.

- The readings (movement of the hand) are taken from the accelerometer attached on the hand. These readings are sent to Arduino uno.
- Through Arduino the readings are encoded by HT12E. The Encoder sends these readings through RF transmitter to the receiver attached on the car.
- These readings are sent to the receiver and are decoded by HT12D. After the readings are decoded they are sent to L298N motor driver due to which the motors are moved. Thus the movement of car is achieved

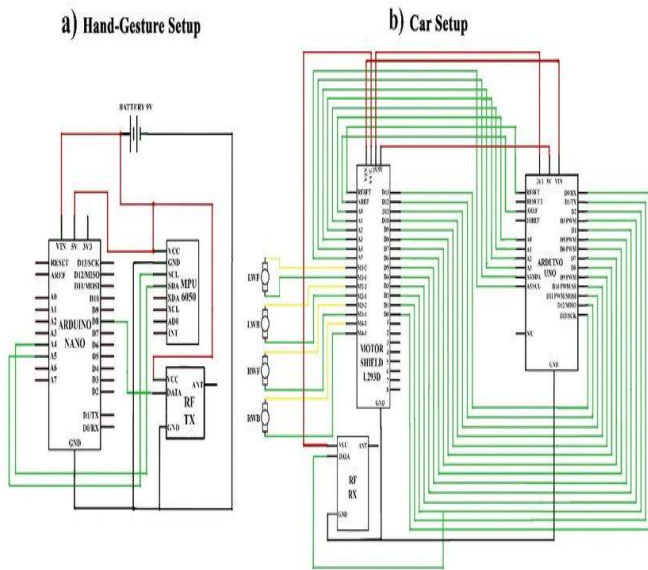

B. Working

- There are five hand gestures which can be recognized by the car. They are STOP, RIGHT, LEFT, BACKWARD, FORWARD.
- The following are Results of the hand gestures used in controlling the car & Obstacle Avoidance.

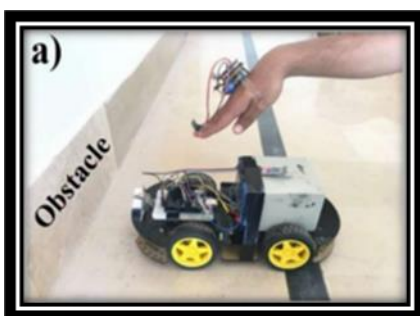
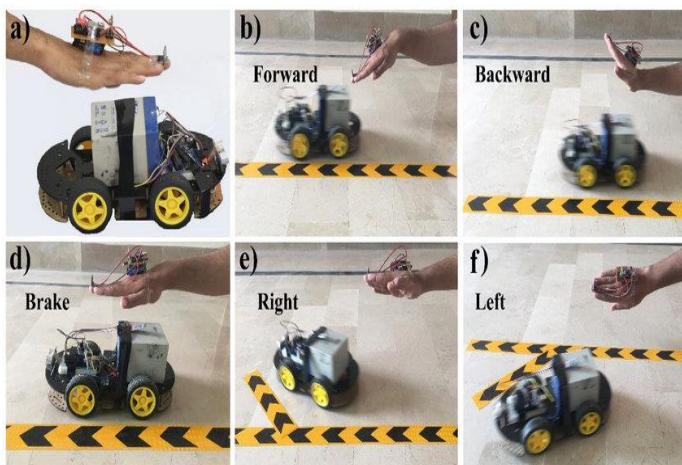

CONCLUSION

The introduction of IoT and combination of IoT and physical devices makes life easier. The tasks which are dangerous and hazardous can be done very easily. The introduction of IoT also completes the tasks in a very short duration of time. More over the human errors are reduced on a great scale and results are achieved with great accuracy.

In conclusion, the obstacle avoidance system developed for the RC car has proven to be a significant enhancement to its functionality and safety. By integrating sensors, microcontrollers, and motor control mechanisms, we have successfully enabled the RC car to navigate through a variety of environments while avoiding obstacles in its path.

REFERENCES

- [1] www.igniteinnovateideas.wordpress.co.in
- [2] www.researchgate.net
- [3] www.elprocus.com/accelerometer-based-gesture-control-robot/
- [4] www.create.arduino.cc/projecthub
- [5] J. Pradeep, Dr .P. Victor Paul” Design and Implementation of Gesture Control Robotic Arm for Industrial Applications”, International Journal of Advanced Scientific Research & Development ,vol.03,pp.202-209,Oct-Dec’2016
- [6] Deepak Rasaily, Manoj Gurung, Nelson Rai, Rit Kr. Khawas and Tashi Rapden Wangchuk “Bluetooth Remote Controlled Car using Arduino”. IJETT (Volume 33 Number 8- March 2016).
- [7] Article “An Automated Robot-Car Control System with Hand-Gestures and Mobile Application Using Arduino”, by Saleem Ullah, Zain Mumtaz, Shuo Liu, Mohammad Abubaqr , Athar Mahboob and Hamza,Ahmad Madni