

VEHICLE SAFETY ENHANCEMENT BY INSTALLATION OF UNIQUE CONTROL ATTACHMENT IN STEERING SYSTEM WITH MOVABLE HEADLIGHTS

Dr.D. Satheesh Pandian¹, Mrs.D.Thangamari², Mr.M.Mohanraj³

¹Associate Professor, Dept. of Mechanical Engineering, K.L.N. College of Engineering, Sivagangai (D.t), Tamilnadu, India

²Assistant Professor, Dept. of Computer Science Engineering, K.L.N. College of Engineering, Sivagangai (D.t), Tamilnadu, India

³Assistant Professor, Dept. of Mechanical Engineering, K.L.N.College of Engineering, Sivagangai (D.t), Tamilnadu, India

ABSTRACT

The standard method of steering involves the use of a manually operated steering wheel positioned in front of the driver. This steering wheel is connected to the front wheels through a steering column, which is equipped with universal joints to enable slight deviations from a straight line. Different arrangements can be observed on various types of vehicles. For instance, a tiller or rear-wheel steering may be utilized. Tracked vehicles like tanks typically utilize differential steering, where the tracks move at varying speeds or even in opposite directions to alter the course. The focus of this paper, however, is on front wheel steering, which incorporates movable headlights and the latest inter-electronic technology.

Keywords: Movable Head Light, steering system, vehicle safety

1 INTRODUCTION

Vehicle safety aims to reduce the occurrence of traffic accidents or mitigate the detrimental consequences of accidents, particularly those that impact individuals' well-being and physical condition. Safety mechanisms have been incorporated into automobiles for many years, with certain features designed specifically to protect the passengers inside the vehicle, while others are meant to safeguard others on the road. The development and production of a steering-controlled Headlight system, designed to enhance the safety of the vehicle. This apparatus pertains to a headlight setup for automobiles, specifically designed to be linked to the vehicle's steering system in order to light up the intended route of travel.

This system comprises of support brackets that can be operated to connect headlight supporting members onto a frame portion of the vehicle. There are linkage means that interconnect the brackets, allowing them to move together. Additionally, there are means that connect one of the brackets to the vehicle's connector rod. As a result, the

brackets and headlight members are able to move in relation to the direction of vehicle travel. This device pertains to a headlight setup that is linked to the steering and front wheel assembly of a vehicle in order to ensure that the headlight components and front wheels remain aligned at all times. The steering mechanism enables the driver to navigate the moving vehicle along the road and make desired right or left turns. Moreover, the maneuvering of the vehicle should not demand increased exertion from the driver. Ensuring car safety involves preventing car collisions and reducing the detrimental consequences of such incidents.

In a conventional front wheel steering system, the rear wheels do not rotate towards the curve, thereby limiting the effectiveness of the steering mechanism. Nevertheless, the rear wheels in these systems were only steered by 2 or 3 degrees, with the primary goal of aiding the front wheels rather than steering independently. While a sophisticated four-wheel steering system for production has not been developed, several experimental prototypes incorporating cutting-edge technologies have been constructed and tested with positive results.

Typically, when vehicles make turns, the tires experience the effects of grip, momentum, and steering input. However, when the vehicle deviates from driving straight ahead, the tires encounter road grip and slip angle. Traction ensures the car's tires grip the road surface, while momentum propels the car forward in a straight line. The car briefly opposes turning, resulting in the tire losing traction. As soon as the vehicle starts to react to the steering command, lateral forces are produced. The car flips over as the back wheels attempt to mimic the cornering forces produced by the front tires. Due to the time lapse between the control signal and the vehicle's reaction, this occurrence is referred to as tail lag. When the steering wheel is turned, the vehicle's frame sways and the rear wheels once more attempt to align with the cornering forces produced by the front wheels.

The concept behind all-wheel steering is that when all four wheels are actively steering, the driver needs to provide less input for each steering maneuver. Just like two-wheel drive vehicles, tire traction is crucial for keeping all four wheels in contact with the road. Nevertheless, when the driver makes a slight turn of the steering wheel, all four wheels react to the steering inputs, resulting in drift angles occurring at each of the four wheels. The car reacts faster to steering commands as the delay in the rear wheels has been removed.

The rear wheel steering direction is determined by the prevailing operating conditions. At low speeds, there is a noticeable movement in the wheels, causing the rear wheels to turn in the opposite direction of the front wheels. Additionally, this feature simplifies the process of maneuvering the vehicle, especially when navigating through narrow parking spaces.

The back wheels of a car with four-wheel steering do not turn in the typical way as they are engineered to follow the trajectory established by the front wheels on the pavement. As a result, the chances of running into an obstacle are greatly reduced. When operating a vehicle at high velocities and making minor adjustments to the steering, the front and rear wheels will both rotate in unison. As a result, the car moves laterally in a manner similar to a crab, instead of tracing a seamless curved path.

This maneuver is advantageous for the vehicle when changing lanes on a high-speed highway. The elimination of the centrifugal force reduces body roll and cornering forces on the tire, improving the stability of the vehicle and making it easier to control, thus enhancing safety. Throughout this study, our primary objective has been to reduce the vehicle's turning radius, improve safety measures to prevent nighttime accidents, and optimize the vehicle's parking capabilities in designated areas. We have meticulously selected pertinent sources to bolster our research endeavors. Numerous individuals have presented their viewpoints on these matters. The alignment of the headlight with the wheel is displayed below.

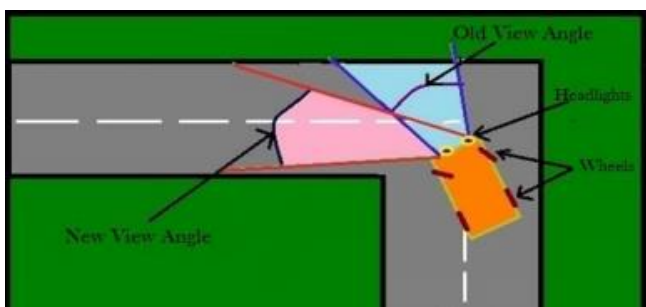

Fig 1.0: Head Light Alignment with Wheel

2 LITERATURE SURVEY

Saket Bhishikar, et.al developed a four-wheel steering system due to the fact that the rear set of wheels remain fixed in a forward direction and do not actively contribute to steering control. An inventive 4 wheel steering design has been created to incorporate a mechanism capable of altering the steering of the rear wheels in both in-phase and counter-phase, depending on the turning and lane changing conditions in relation to the front wheels. This advancement significantly improves the maneuverability of a sedan in accordance with its speed. This system aids in swift lane changes and improved maneuvering around corners.

It addresses the challenges encountered during sharp turns by decreasing the car's turning circle radius, enhancing maneuverability and control at high speeds, ultimately achieving neutral steering.

In 2009, Jack Erjavee stated that when the vehicle is traveling at a high speed and requires slight steering adjustments, it is necessary to turn both the front and rear wheels in the same direction. Consequently, the vehicle maneuvers in a sideways motion resembling that of a crab instead of following a smooth curved trajectory. This behavior proves advantageous for the car while executing lane changes at high velocities on a highway. Enhancing stability by reducing the centrifugal effect and minimizing body roll and cornering force leads to improved control, making it easier and safer to maneuver. This article provides details on a crucial aspect of a four-wheel steering system, which is the control of the drive angle at both the front and rear wheels.

In their study, K. Lohith, et.al concluded that the implementation of four-wheel steering represents a significant endeavor by automotive design engineers to achieve a steering system that is close to neutral. Maruti Suzuki 800 is regarded as a benchmark vehicle in their paper. The primary objective of this endeavor is to synchronize the rear wheels with the front wheels in an opposite phase. To accomplish this objective, a mechanism was devised that comprises of two bevel gears and an intermediate shaft. This mechanism not only transfers 100% torque but also rotates the rear wheels in an out-of-phase manner.

In their study, Dilip S Choudhari¹ et.al reach the conclusion that the steering of both the front and rear wheels can be adjusted based on the vehicle's speed and the amount of space available for turning. The primary objective is to ensure that steering the vehicle does not demand excessive effort from the driver. The Quadra steer steering system provides a 21% decrease in the turning radius. If a vehicle can perform a U-turn within a 25-foot area, Quadra steer enables the driver to accomplish it

within approximately 20 feet. Hence, the four-wheel steering system possesses the ability to navigate corners, respond to steering inputs, maintain stability on straight roads, facilitate lane changes, and enhance maneuverability at low speeds.

Manisha V Makwana, along with others, constructed the hardware for a mobile Headlight System designed for motor vehicles. The utilized system incorporates a rack and pinion arrangement, enabling the transmission of power to the optical axes where the headlights are positioned. Consequently, when the tie rod arms are manipulated by the steering arm, both the wheels and the headlights are subjected to a predetermined motion. This mechanism assists in adjusting the position of the headlights to the left or right based on the need during turns, thereby aiding in minimizing nighttime accidents on winding roads and hilly terrains.

Gadhavre Yogesh V, along with others, presented the "Steering Controlled Headlight Mechanism" that functions as headlights that adjust direction based on steering input. It was noted that rotating the steering wheel to the right by a specific angle causes the headlights to tilt to the right by a certain degree, thanks to various linkages positioned in relation to the steering wheel as previously explained. Similar characteristics can be noted when the steering wheel is rotated towards the left.

The study by Ajay R. Pawar, Mandhare et.al focuses on a system that can be implemented in various types of four-wheel vehicles, trucks, trailers, etc., without causing financial strain on the user. However, its unique feature lies in its adaptability based on the vehicle's turning radius. During the night, a significant expansion in the observable region is noticed. The developed headlight system offers a significant benefit in its exceptional adaptability, allowing for seamless integration into a wide range of vehicle designs. Additionally, the system is cost-effective, uncomplicated, and straightforward to assemble.

3 MATERIAL SELECTIONS

The selection of materials is a crucial stage in the design process of any tangible item. When it comes to product design, the primary objective of material selection is to reduce expenses while achieving the desired product performance targets. The process of systematically choosing the most suitable material for a specific application commences by evaluating the properties and costs of potential materials.

3.1 MILD STEEL

Mild steel can be chosen here, with the rationale for its selection outlined beneath. Mild steel, also known as plain-carbon steel, is widely used due to its affordable price and

satisfactory material properties for various applications, surpassing those of iron. Low-carbon steel is composed of around 0.05–0.3% carbon, which gives it the properties of being easily shaped and flexible. Mild steel exhibits a modest tensile strength, yet it is cost-effective and pliable; carburizing can enhance its surface hardness. Large quantities of steel are frequently utilized, particularly as structural steel, due to its high demand. Mild steel has a density of 7850 kg/cm³ and a Modulus of Elasticity of 210 GPa (30,000,000 psi).

3.2 REASONS FOR CHOOSING MILD STEEL

- Cast iron has a lower melting point in comparison to steel.
- Steel is produced by incorporating a regulated quantity of carbon.
- Steel is gentle, more difficult to mold, and possesses a relatively high viscosity.
- Steel remains intact when subjected to bending forces.
- Steel possesses a higher level of tensile strength.
- Steel is superior in tension.

3.3 SELECTION OF BEARINGS

A ball bearing is a form of rolling-element bearing that employs balls to uphold the gap between the bearing races. The primary objective of a ball bearing is to diminish rotational friction and provide assistance for both radial and axial loads. Choose a footstep with a minimum inner diameter of 20mm and a radial load carrying capacity of at least 100kg. The ball bearing specification is 25x50x15mm.

3.4 JOURNAL BEARING

The bearing is equipped with rubber seals on both ends to retain lubricant and prevent contaminants from entering. It is pre-lubricated by the manufacturer, eliminating the need for any extra lubrication. This sealed ball bearing with a deep groove is designed for applications requiring both radial and axial loads, as well as high running accuracy at elevated rotational speeds. Various applications encompass clutches, transmissions, gearboxes, compressors, pumps, turbines, as well as printing and textile machinery, among other examples.

3.5 WHEEL SELECTION

In this instance, we are choosing the alloy wheels for the manufacturing process. Alloy wheels are crafted from a blend of aluminum or magnesium. Alloys consist of a combination of metal and additional elements. Typically, they offer increased strength compared to pure metals,

which tend to be softer and more malleable. Aluminum or magnesium alloys are generally lighter than steel wheels of the same strength, offer superior heat conduction, and frequently result in enhanced aesthetic appeal. Steel, the most frequently utilized material in wheel manufacturing, is a combination of iron and carbon. However, the designation "alloy wheel" typically refers to wheels crafted from nonferrous alloys.

3.6 LIVE AXLES WITH CV JOINTS

The operation of the final drive and differential assemblies in the live front axles mirrors that of rear axles. Gear ratios designed to boost engine torque will match those found in the rear axles of the vehicles. When the vehicle moves in a straight line, the inner and outer axle shafts are aligned. If the front axle is connected to the power train, the inner axle shaft will propel the cv joints. These joints will then rotate the outer axle shafts, which are connected to the wheel hubs.

As the steering arms and rods rotate the knuckles, the axle shafts will experience flexion at the CV joints. While making turns, the CV joint will consistently provide a seamless and steady transmission of torque. The steering linkages simultaneously adjust the steering knuckles to the appropriate angle for the turn.

3.7 STUB

The purpose of this component is to transfer power from the live axles and can also serve as a steering mechanism. Its primary function is to facilitate the smooth rolling of the wheels on the road. Depending on the steering adjustments, the wheel can be either toe-in or toe-out.

4 PROBLEM DEFINITION

Currently, all vehicles operate using a two-wheel steering system. However, it has been demonstrated that the conventional two-wheel steering system is less efficient when compared to the four-wheel steering system. Therefore, this study aims to highlight the superiority of the four-wheel steering system over the two-wheel steering system in terms of turning radius. Typically, a vehicle that possesses a larger turning radius encounters difficulties when it comes to parking and maneuvering at low speeds. However, passengers tend to favor vehicles with an extended wheelbase and wider track width as it provides enhanced comfort during travel.

In this situation, the utilization of four-wheel steering will prove beneficial by reducing the turning radius for a vehicle with an extended wheelbase. The study involves modifying a benchmark vehicle to incorporate a four-wheel steering system without altering its original dimensions. To achieve reduction, a mechanism has been constructed

wherein the rear wheels are turned in the opposite direction to the front wheels. This affects the driver's visibility during nighttime, making it difficult for them to accurately assess road turns, particularly on sharp bends in hilly regions, due to the occurrence of road accidents. Driving a four-wheeler can be challenging, especially when navigating sharp turns. This particular model assists drivers by automatically adjusting the focus of the headlights based on the direction of the steering wheel. Adaptive headlights are designed to respond to the car's steering system and automatically adapt to provide optimal illumination for the road ahead. When the car turns left, the headlights adjust their angles accordingly to the left. Instead of relocating the headlights, reflectors are installed internally on both sides of the headlamp housing. These reflectors are adjusted in order to guide the beam.

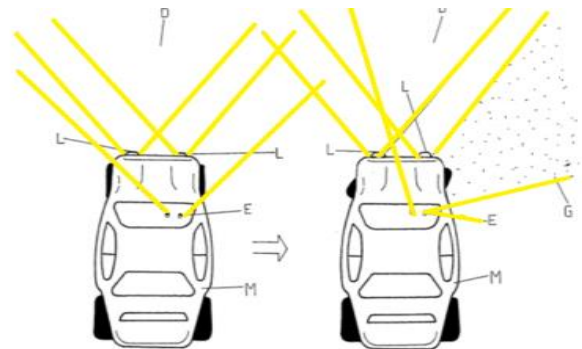

Fig 2.0: Head Light Coverage of Four Wheeler

The reflectors are moved in the same direction as the vehicle's movement, and the power needed for this motion is transferred through hydraulic linkages.

4.1 PROBLEM RECTIFICATIONS

- Our study aims to demonstrate the superiority of the four-wheel steering system over the two-wheel steering system in relation to turning radius.
- In this study, we examine the application of a four-wheel steering mechanism on a benchmark vehicle, while keeping its dimensions unchanged.
- We have successfully decreased the turning radius in comparison to alternative steering systems.
- Adjust the headlights while making a sharp turn with the steering wheel.
- We strive to maintain the parallel alignment of the headlight beam with the road as much as we can while making a turn.
- Enhancing the driver's visibility during nighttime to enable better judgment of road curves.
- It is crucial to take measures to avoid road accidents during nighttime, particularly when encountering sharp turns, especially in hilly regions.

5 FABRICATIONS

Fabrication plays a crucial role in every paper, as it involves transforming our ideas into tangible models. In the context of this particular endeavor, the fabrication process focuses on creating a four-wheel steering system. Our paper necessitates the attachment of numerous items to the frame. The fabrication process involves the utilization of multiple machines.

The implementation of a four-wheel steering system with adjustable headlights is accomplished through a series of processes, which include:

- Gas cutting
- Grinding
- Drilling

In this paper, the tri-star clamp is employed to connect the wheels in unison. Ascending stairs becomes arduous when using a single wheel.

The wheels are linked to the arms of the clamp, and as the Tri-Star setup ascends the stairs, it rotates upon reaching the stair edge. The Tri-Star undergoes fabrication through the gas cutting process. The wheels are positioned between the two clamps utilizing air cooled arc welding.

5.1 FINAL ASSEMBLY

- At first, we secured the live axle and the stubs during the initial phase of assembly. Subsequently, we drilled 12mm holes at the rear end of the frame to facilitate the attachment of the live axles. The stubs are connected to the tyre sets following the axles. The tub is responsible for providing both steering and power transmission to the wheels.

- Subsequently, clamps are positioned to secure the sun gears that are welded at the center of the frame.

- The sun gear position is connected to two tie rods from each side of the stub, allowing us to secure the tie rods to the sun gears with 10mm long threaded bolts.

- The procedure described is also carried out for the lower sun gear.

- The tie rod is connected to tie rod ends on both sides, which are secured to the sun gears at the rear end.

- Two tie rods extend from the front wheel C-clamp and are secured to the steering column using elongated fully threaded bolts.

- The journal bearing is utilized to firmly secure the shaft responsible for transmitting the steering motion from the front to the rear wheels, ensuring a solid connection.

- Ultimately, put together the tire sets.

- Following the completion of the final assembly frame, it undergoes testing. Subsequently, measurements such as the turning radius before and after meshing are taken, along with the sun and planet gear meshing.

- Subsequently, the headlights are positioned on the wheel clamps in an L-shaped configuration, representing the most basic type of adjustable headlamps based on the vehicle's steering. The steering enables them to rotate up to a maximum angle of 120 degrees. The connections are established based on the automobile's design and requirements.

5.2 WORKING PRINCIPLE

This patent pertains to a vehicle headlamp, specifically a mobile vehicle headlamp mechanism that provides illumination in the direction the vehicle is turning.

Typically, conventional headlights and auxiliary lights are permanently positioned at a specific angle on the front of a vehicle's body to illuminate the area ahead of the car. Hence, when the steering wheel is turned to alter the car's travel direction, the front-wheel aligns itself at an angle that corresponds to the degree of the steering wheel's turn in relation to the car's original direction of travel. Hence, the vehicle's chassis shifts towards an unilluminated path, thereby presenting a hazard as it transforms into an obscure region.

The objective of the present invention is to offer a unique car headlight device that automatically illuminates the direction in which the car is turning when the car is being turned. To be more precise, the movable car headlight mechanism of the current innovation consists of a vertical main axis that is securely attached to a bracket positioned on a suitable section of the car's body. There is a receiving table that the main axis passes through, and a rotating body with balance weights on both sides is connected to the main axis. This body is capable of rotating and rests on the receiving table. Additionally, there is a casing located at the upper end of the main axis, which supports a lamp at its rear part and is also rotatable. The casing is linked to the rotating body in a manner that enables independent upward or downward movement of the rotating body while also co-rotating with the casing.

The contact between the receiving table and the rotating body is designed in the shape of a V-shaped wedge. This allows the rotating body to rise up from the contact surface as it rotates, thanks to the centrifugal force exerted by the balance weights caused by the car's movement. As a result, the casing with a lamp is rotated, and the rotating body receives a restoring force from the potential energy accumulated by rising up the V-shaped surface of the receiving table.

6 SOLIDWORKS SOFTWARE

SOLIDWORKS, created by Dassault Systems, stands as a premier CAD/CAM/CAE software globally. As a robust modeling platform, it seamlessly integrates 3D parametric

capabilities with 2D tools, while also encompassing the entire design to manufacturing workflow. In addition to offering a glimpse into the design content, the package fosters cooperation among businesses and gives them a competitive advantage.

Furthermore, within the drawing mode of Solidworks, it is possible to generate 2D drawing views alongside the creation of solid models and assemblies. These drawing views encompass a range of options such as orthographic, section, auxiliary, isometric, and detail views.

Solidworks utilizes parametric design principles in solid modeling. This software offers a method for automating mechanical design through solid modeling technology and various features.

6.13D MODELING

The fundamental distinction between solidworks and conventional CAD systems lies in the fact that the models generated in solidworks are tangible 3D solids. Solid works models the entire solid, unlike other 3D modelers that only depict the surface boundaries of the model. This not only enables the generation of lifelike geometry, but also ensures precise model computations, particularly for mass characteristics.

6.2PARAMETRIC DESIGN

Solid works model geometry is influenced by dimensions like angle, distance, and diameter. By establishing relationships, parameters can be automatically computed depending on the values of other parameters. When altering the measurements, the complete model structure can be adjusted in accordance with the established relationships.

6.3 FEATURE – BASED MODELING

The models are constructed by using Solid Works with object features. These features possess a level of intelligence, as they possess knowledge about their surroundings and can adapt in a predictable manner to any alterations. The user is prompted to provide specific information for each feature, depending on its type. For instance, a hole requires the user to input its diameter, depth, and placement, whereas a round feature requires the user to specify its radius and the edges to be rounded.

6.4 ASSOCIATIVITY

Solid works operates as a completely associative system, ensuring that any modifications made to the design model at any stage of the development process are reflected across all engineering deliverables such as assemblies, drawings, and manufacturing data without manual intervention. Associatively facilitates the

implementation of concurrent engineering by promoting flexibility, allowing for modifications without any negative consequences at any stage of the development process. This empowers downstream functions to share their insights and expertise at an early stage in the development cycle.

6.5 CAPTURING DESIGN INTENT

Parametric modeling's power lies in its capacity to meet essential design parameters as a solid model progresses. The notion of capturing design intent is rooted in integrating engineering expertise into a model. The objective is accomplished through the establishment of characteristics and component connections, as well as the implementation of the feature dimensioning plan.

6.6 DIAGRAM

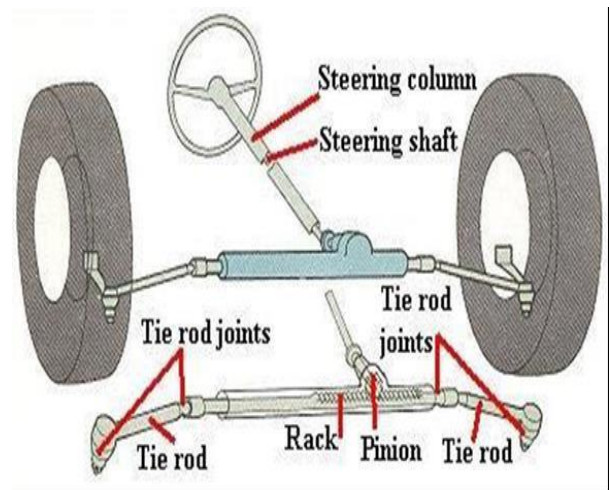

Fig: 3.0 Assembled View of Movable Head Light

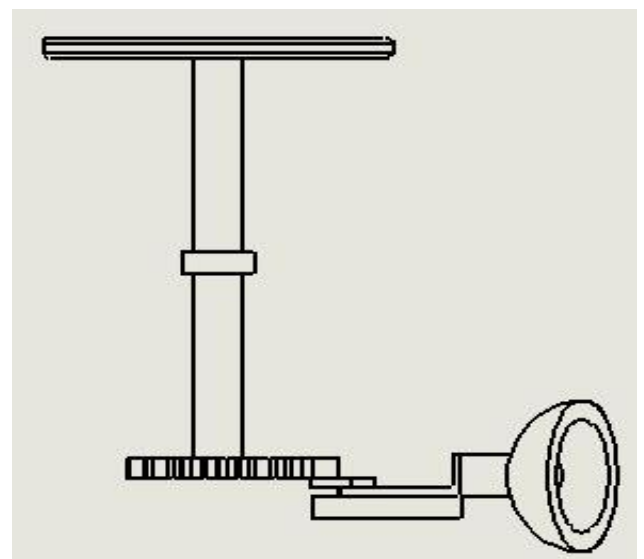

Fig: 4.0 Side View of Head Light

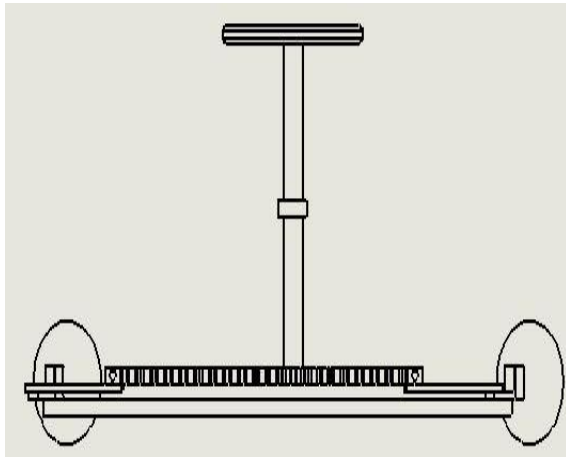

Fig: 5.0 Back Side View of Head Light Arrangement

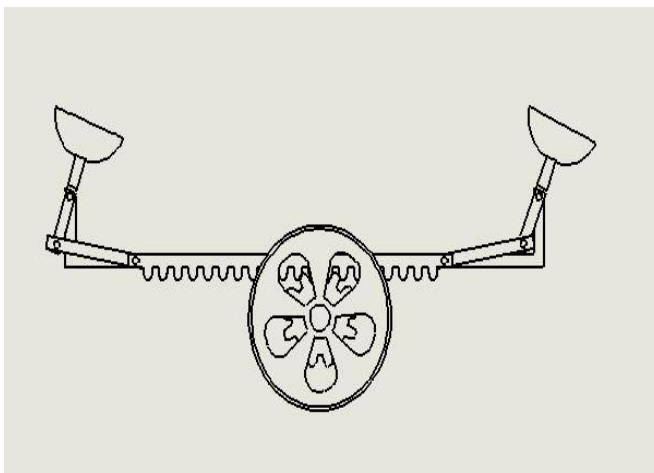

Fig: 6.0 Rack and Pinion Arrangement

6.7 RACK AND PINION

A rack and pinion is a form of linear actuator consisting of two gears that transform rotational movement into linear motion and vice versa. The pinion, a circular gear, meshes with teeth on a linear bar known as the rack. By applying rotational motion to the pinion, the rack moves in relation to the pinion, effectively converting the rotational motion into linear motion. Each set of complementary involute profiles corresponds to a fundamental rack. This fundamental rack represents the profile of the complementary gear with an infinite pitch radius (i.e. a toothed straight edge). Rack and pinion assemblies are commonly employed in basic linear actuators, transforming the rotational movement of a manually or motor-driven shaft into linear motion. The actuator's entire load is borne by the rack, resulting in a typically small driving pinion.

This design choice allows for a reduction in torque requirements due to the gear ratio. However, the force or torque involved may still be significant. Therefore, it is customary to incorporate a reduction gear, either in the

form of a gear or worm gear, immediately preceding the actuator to further reduce the torque. Rack gears possess a superior ratio, consequently necessitating a larger driving torque in comparison to screw actuators. Within this undertaking, when pressure is exerted on the pedal, it is transmitted to the spring that is connected to the bottom of the rack. Subsequently, the rack moves and simultaneously causes the pinion to rotate as well.



Fig: 7.0 Rack and pinion

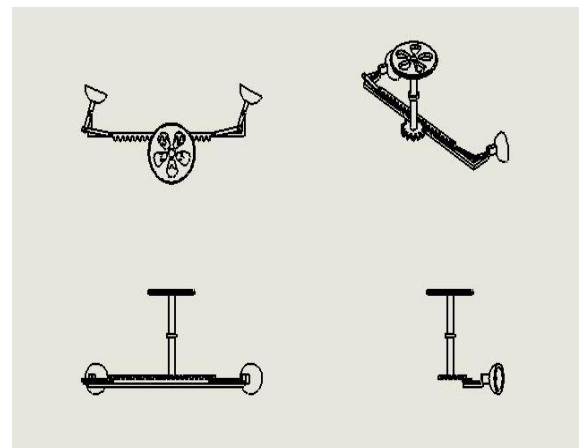

Fig: 8.0 View of Individual Assembly

6.8 FRAME

In the realm of construction, framing, also referred to as light frame construction, is a method of building that revolves around the utilization of structural elements, commonly known as studs. These studs serve as a sturdy framework to which both interior and exterior wall coverings are affixed.

Additionally, this framework is further reinforced by horizontal joists and sloping rafters or pre-fabricated roof trusses, which are concealed by a range of sheathing materials. Light frame material sizes vary from 38 mm by 89 mm (1.5 by 3.5 inches, also known as a two-by-four) to 5 cm by 30 cm (two-by-twelve inches) in terms of cross-section dimensions, with lengths ranging from 2.5 m (8

feet) for walls to 7m (20 feet) or longer for joists and rafters.

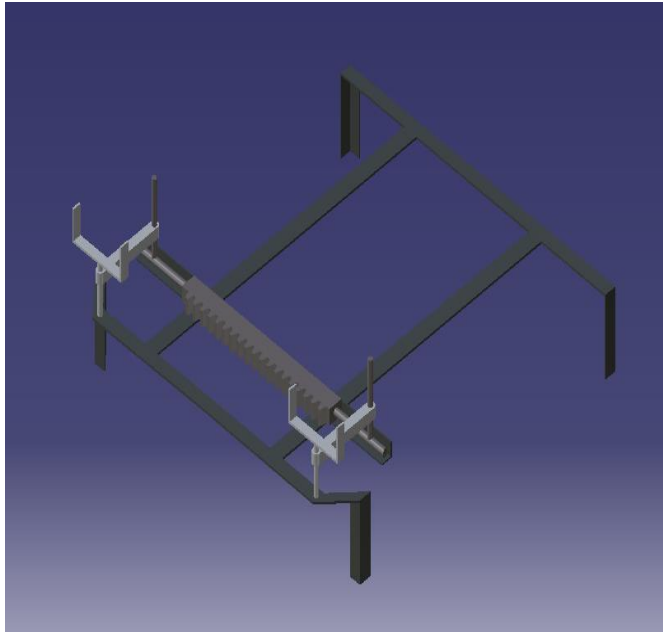

Fig: 9.0 Frame

7 ADVANTAGES

- The ride on curved roads, particularly on ghat roads, is both smooth and safe.
- Offers a liberating experience for the driver's mind.
- Ensures the country's roads remain accident-free.
- This safety measure has been enhanced and implemented in automobiles.
- User-friendly..
- The amount of manual power needed is reduced.
- Fixing the issue is a straightforward task.
- It is simple to replace components.
- There is no requirement for excessive lubrication.

8 APPLICATIONS

- The steering-controlled headlight system can be implemented in large vehicles like buses and trucks, primarily used on steep and winding roads.
- Tailored for installation in buses that operate on mountainous ghat roads.
- This mechanism can be installed in various commercial vehicles including Maruthi, Ambassador, Fiat, Mahindra, Tata, and more.

9 DESIGN OF RACK AND PINION SPUR GEAR

To develop the design of our steering box's rack-pinion mechanism, we focus on selecting the rack and pinion that will result in a larger sideways movement of the wheels when the steering wheel is turned. Another initial

consideration is that both the rack and the pinion should have matching modulus and be made of the same material. An appropriate material for these components is SAE 1045 steel, known for its ease of manufacturing.

9.1 DESIGN CALCULATION

Ultimate tensile strength (S_{ut}) = 625 N/mm².

Assumptions:-

Number of teeth on pinion = 12

Number of teeth on rack = 28

Pitch line velocity of pinion = 0.5 m/sec.

Tangential force on pinion = 600 N.

Results:-

Standard module $m = 2$ mm

Hence dimension of spur pinion:

$$D_p = Z_p * m = 12 * 2 = 24 \text{ mm}$$

$$B = 15 * m = 15 * 2 = 30 \text{ mm}$$

Pressure angle = 20°

Addendum = 1 m = 2 mm

Dedendum = 1.25 * m = 2.5 mm

Pitch (p) = 6.0283 mm

We have a pinion with a diameter of 24 mm,

$$T = 105.948 * 12 = 1.27136 \text{ Nm}$$

This is the torque in the pinion which is transmitted through the steering column.

9.2 STEERING MOVEMENT RATIO

Therefore the movement ratio is 12.47:1

The output load will be:

$$F = 2 * MR * F = 2 * 20 * 12.47 = 498.8 \text{ N}$$

Load transmitted to the tie rods is 498.8 N.

CONCLUSION

According to the objectives, we have developed a cutting-edge four wheel active steering system featuring movable head lights. This mechanism is not only feasible for production, but also highly effective in achieving neutral, in-phase, and counter-phase rear steering in relation to the front wheels. This particular system enhances cornering performance and facilitates quick lane

changes at high speeds. It resolves the issue encountered during sharp turns. Even when traveling at high velocities, it enhances maneuverability and control by reducing the turning circle radius, similar to neutral steering. Furthermore, these systems are not only practical and cost-effective, but their components are readily accessible in the market as well. The installation process for the system is straightforward, and it is lightweight, making it efficient for implementation in all areas of automobiles. The inclusion of headlights as a mandatory requirement, coupled with the added advantage of turn signals, serves to decrease accidents during nighttime in areas with sharp turns and hills, ultimately contributing to the creation of accident-free roads nationwide. It has been discovered that when the steering wheel is turned in either direction, the headlights are adjusted accordingly through the use of a rack and pinion mechanism.

REFERENCES

- [1] Dilip S Choudhari, "Four wheel steering system for future", International Journal Of Mechanical Engineering and Robotics Research, ISSN 2278 – 0149, Vol. 3, Page No 383-387, Issue 4, October 2014.
- [2] N.Laxmi, B.AnilKumar, D.Kiranvarma, "Design and Fabrication of A Steering Controlled Headlights in Automobile", International Journal & Magazine of Engineering, Technology, Management and Research, volume 13, issue 17, Page No 98-102, July 2015,
- [3] Ajay R, S. Salekar, U. Mandhare, Sachin D, Sanket S, "Design And Fabrication Of Movable Headlight System" International Journal of Advance Engineering and Research Development(IJAERD), Volume 4, Issue 5, Page No 254-259, May -2017, P-ISSN (P): 2348-6406
- [4] J.B. Jiang, C.F. Cheung, S.To, K.W. Cheng, H. Wang, W.B. Lee "Design and fabrication of free form reflector for automotive headlamp" 2nd International Conference on Power Electronics Systems and Applications : Hong Kong, 12-14 November 2006, p. 220-224.
- [5] Gadhave Yogesh V, Jadhav Chakradhar R, Aher Ravindra T, Sonawane Umesh A, Mali Praveen K, "Front Wheel Steering With Movable Head Lights",IJARIIE,Vol-3,Page No 1623-1628, Issue-3 2017, ISSN(O)-2395-4396
- [6] Hiroaki Okuchi, Kunio Ohashi, Yuji Yamada, Yoshiyuki Miki "Automatic optical-axis adjusting device for automatically adjusting directions of optical axes of front lights with respect to steering angle of steering wheel" Dec 30, 2003,US6671640 B2.
- [7] Sawalha, S. A., Abu-Mansour, T. M., & Al-Salem, N. M. Steering Speed Suspension Device (Triple" S" device), to Prevent Burnouts–Tafheet Phenomena.
- [8] Masanori Kondo, Kunio Ohashi, Yuji Yamada, Yoshiyuki Miki, "Automatic optical-axis adjusting device for automatically adjusting directions of optical axes of front lights",10 Feb 2004, US6688761 B2
- [9] K. Lohith, Dr. S. R. Shankapal, & Mr. H. Monish Gowda "Development of Four Wheel Steering System for a Car," SAS Tech Journal, vol. 12, pg. 90-97, Issue 1, April 2013.
- [10] Dr. Kirpal Singh "Automobile Engineering" Standard Publishers Distributors, vol. 1, 12th Edition, 2011.
- [11] V. B. Bhandari " Design of Machine Elements" McGraw Hill Education India Pvt. Ltd., vol. 3, 11th Edition, 2013
- [12] Manisha V Makwana, Akshay Shah, Shankar Rahul and Ajay M Patel, et. all "Design and Manufacture of Movable Headlight System in Automobile", International Journal of Innovative and Emerging Research in Engineering, e-ISSN: 2394 – 3343,Volume 1,Page No 12-16, Issue 2, Dec2014
- [13] Saket Bhisikar, Vatsal Gudhka, Neel Dalal, Paarth Mehta, Sunil Bhil, A.C. Mehta, "Design and Simulation of 4 Wheel Steering System", International Journal of Engineering and Innovative Technology (IJEIT), Volume 3, Issue 12, Page No 351-367, June 2014.
- [14] Ramkumar, C., Kumar, H. P., & Krishnaprasanth, S. EAACM: Enhanced Ack aware clustering mechanism for energy efficient and secure routing in wireless sensor networks.
- [15] Chi on-dong lin, "Steering wheel controlled car light piloting system", A International Journal of Innovative and Emerging Research in Engineering Volume 1, page no 354-367, Issue 2, 2014-16.

BIOGRAPHIES

Dr.D.Satheesh Pandian attained his B.E. in Mechatronics Engineering, M.E. in Industrial Engineering and Ph.D in Mechanical Engineering. He is affiliated with K.L.N. College of Engineering as Associate Professor. His research interests are Mechatronics, Robotics, Automation and Image Processing.



Mrs.D.Thangamari completed her B.E. in Computer Science Engineering, and M.E Computer Science Engineering, She is affiliated with K.L.N.College of Engineering as Assistant Professor. Her research interests are Artificial Intelligence, Machine Learning and Robotics.



Mr. M. Mohanraj completed his B.E. in Mechanical Engineering, and M.E. in Engineering Design. He is affiliated with K.L.N.College of Engineering as Assistant Professor. His research interests are Mechanical component design, Robotics and Automation.