

IMPROVED HYBRID SPECTRUM SENSING METHOD FOR COGNITIVE RADIO NETWORKS

¹F. O Adunola, ²O. A Sadiq, ³A. Danladi and ⁴K. B Labbo

Department of Electrical and Electronic Engineering, Nigerian Defence Academy, Kaduna

ABSTRACT

The Improved Hybrid Spectrum Sensing Method (IHSM) for cognitive radio networks, based on hybridization of Matched Filter Detection (MFD) and Cyclostationary Feature Detection (CFD) techniques used to improved detection performance and reduced computational complexity. This method operates in such a way that the matched filter receives the licensed user or primary user (PU) signal and senses a quarter number of the samples. When Matched Filter Detection (MFD) lacks sufficient knowledge of PU, it shifts to Cyclostationary Feature Detection (CFD) while lowering computational complexity in both. The performance for implementation and comparison was tested under Additive White Gaussian Noise (AWGN) and Weibull fading channels in both cooperative and the non-cooperative scenarios. The simulation was obtained on Windows 8.1 using Matlab 2023. The detection probability and the ratio of computational complexity were used to evaluate the performance outcomes of the IHSM. From the results, the IHSM scheme's computational complexity ratio reduced by 18% and 22% compared to the CFD method and the MFD method, respectively, when the number of samples, N is 50. Additionally, the probability of detection in the IHSM increased by 68% and 48%, respectively, as compared to the CFD method and the MFD methods, at signal to noise ratio per bit (E_b/N_o) equal to 0 dB under the Weibull fading channel. The proposed method performed better in both cases but fading, noise and other impairment cannot be completely eradicated at the transmitting and reporting channels.

KEYWORDS: IHSM, CFD, MFD, detection performance, computational complexity, signal to noise ratio per bit, AWGN, Weibull fading channel.

1.0 INTRODUCTION

Nowadays, the use of spectrum has increased as a result of the rising number of users who now consider telecommunication technologies to be essential to life. Inadequate use of the useable spectrum was discovered through numerous studies and investigations [1]. Rapid development in communication technology has greatly increased the usefulness of many handheld and portable devices. These tools offer subscribers cutting-edge services. The majority of these gadgets operate on a specific radio frequency, making it extremely limited in supply [2]. Due to the advent of new applications and the constant demand for faster data speeds, radio frequency (RF) spectrum is getting more and more crowded as a result of the enormous quantity and diversity of wireless devices and applications [3]. The spectrum scarce challenge is becoming more prevalent in various places of the globe. Low spectrum utilisation efficiency in licenced bands and subpar performance of wireless devices in the highly congested unlicensed bands are the results of the rigid, inflexible, and centralised spectrum assignment and management policies that were established by the Federal Communications Commission (FCC) in the United States and the Office of Communications (Ofcom) in the United Kingdom [4]. For the benefit of the authorised users, an environment free from interference is ensured by the fixed frequency allocation. The apex body for management of frequency that allocate bulk frequency and satellite co-ordination issues in Nigeria is the National Frequency Management Council (NFMC) [5]. Pursuant to these functions, the NFMC share responsibility for the administration of radio frequency spectrum for commercial users (i.e. Private Telecom Operators, PTOs) to Nigerian Communication Commission, NCC. While Ministry of Communication and Digital Economy (MCDE) handled the assignment non-commercial radio frequency users includes Government MDAs, Military, Diplomatic Mission, NGOs, Security Operatives, Industries/Companies, Maritime and Aviation sectors. Nigerian Broadcasting Commission, NBC regulate Televisions and Radio broadcasting stations [5, 6].

The majority of wireless networks employ the static spectrum allocation technique, in which the Ministry and Agencies of Government control and long-term assign the spectrum to authorised users for broad geographic areas [6, 7]. This strategy experienced spectrum scarcity in several bands as a result of the users' apparent increase in spectrum demand. As a result, the development of Cognitive Radio systems that intelligently assign spectrum has recently attracted the attention of researchers. The deployment of cognitive radio is based on the notion of dynamic access by unlicensed users.

Opportunistic spectrum access, also known as Dynamic Spectrum Access (DSA), has been put into place to address the issues with spectrum allocation. The DSA permits opportunistic spectrum sharing between licenced and unlicensed users, with the spectrum divided into many frequency bands assigned to one or more users [8].

By dynamically utilising the unused portion of the spectrum band known as the spectrum holes or white spaces [9], which are depicted in Figure 1.1, cognitive radio (CR) has been presented as a viable approach that offers a solution to the spectrum shortage problem.

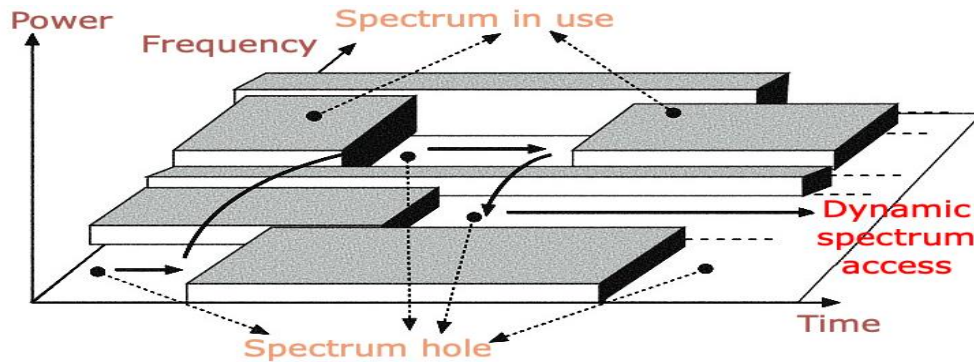

Figure 1.1: Representation of Spectrum Holes [8]

The common definition for Cognitive Radio is given as “a radio for wireless communications in which either a network or a wireless node changes its transmission or reception parameters based on the interaction with the environment to communicate effectively without interfering with the licensed users” [10]. The three main concerns to take into account when designing a Cognitive Radio network are quality of service, interference avoidance, and spectrum sensing [10]. Cognitive radios are characterised by cognitive capability and re-configurability. The objective of Cognitive Radio is to efficiently utilise natural resources, such as frequency, time, and power.

A radio or system that senses and is aware of its operational surroundings and can dynamically modify its radio operating parameters in response can also be described as a cognitive radio [11]. The objective of Cognitive Radio is to efficiently utilise natural resources, such as frequency, time, and power.

Opportunistic spectrum access is made possible by cognitive radio environments. According to Figure 1.2, the primary functions of CR networks are spectrum sensing, spectrum management and decision, spectrum sharing, and spectrum mobility [12].

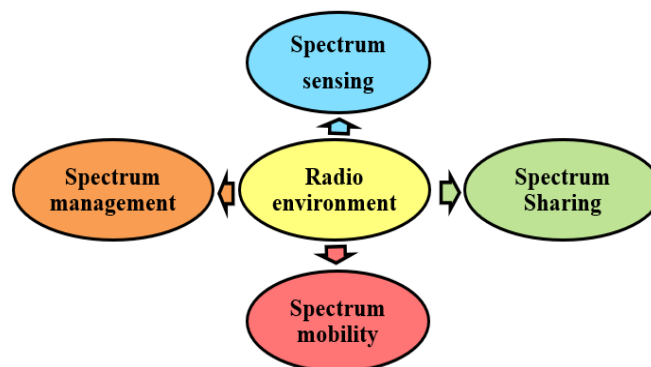

Figure 1.2: Functions of cognitive radio [12]

The following is a brief description of these features. Spectrum sensing is the reliable detection of the unused portion of the primary user spectrum by the sensing and monitoring of the available spectrum bands. Spectrum management/decision is a process for spectrum analysis and judgement based on the results of the spectrum sensor [12]. In Spectrum Decision, the cognitive radio can assign a channel based on the routinely enforced policies and the outcomes of spectrum sensing. Spectrum sharing coordinate among the multiple cognitive users to avoid collisions in the available

portion of the spectrum band. In Spectrum Mobility, the cognitive radio user is seen as a visitor to the primary user spectrum. If the primary user regularly uses the licenced spectrum, a reliable communication cannot be sustained for a long period. In order to continue communicating in other vacant bands, the cognitive radio system should offer mobility [13].

Energy detection (ED), matched filter detection (MFD), and cyclostationary feature detection (CFD) are the three fundamental techniques used for spectrum sensing [14]. Due to its simplicity and low computational complexity, the ED spectrum sensing approach is more popular than others. The ED, however, is unable to distinguish between the PU signal and the noise when the signal-to-noise ratio (SNR) is low and when the channel conditions are poor. MFD is the best detector since it maximizes the received SNR in communication systems [15]. The challenge for MFD is that it needs to be aware of the details of the PU signal features, such as packet format, pulse shaping, and the modulation type. The MFD cannot function as the best detector if the CR contains insufficient data about the PU signal. A less-than-ideal detector option is a CFD. The CFD has the ability to separate the noise from the PU signal. Because of its noise rejection property, CFD performs well in low SNR situations [16]. However, the CFD has a long sensing time, leading to high computational complexity which is undesirable in some circumstances [17].

There are two categories of spectrum sensing techniques: cooperative and non-cooperative. Non-cooperative methods work by identifying signals sent by the main system. It frequently base on guess that the sensing devices are aware of the primary transmission area is known to the sensory devices. Therefore, in order to execute spectrum sensing (SS), the SU should only rely on local detections and detect the weak primary transmission signals. The sensing device's coverage region does not have entire spectrum retention information. Therefore, it is impossible to completely eliminate harmful interference with the PU [18]. Cooperative Spectrum Sensing (CSS) is used in order to improve the performance of the First Priority Users (FPUs) and to minimise the probability values [19]. CSS is used in wireless channels to avoid fading and shadowing in order to improve performance detection. CSS can be divided into two fundamental types: distributed and centralised [20, 21]. In a centralised system, a sensing controller (Base station) senses the spectrum, and the information is then shared with all of the neighbouring nodes. The Second Priority Users (SPUs) can make decisions either independently (non-cooperative sensing) or collectively (cooperative sensing) based on how other SPUs are sensing the spectrum [22]. In CSS, a fusion centre (FC) receives local decisions from a large number of SUs that each independently detect the spectrum. FC is in charge of making the final decision by implementing some type of fusion logic scheme. Finally, a decision regarding the status of the PU is made globally when these local decisions reach the FC [23]. There are two types of decision fusion rules: hard and soft. While under a soft fusion rule, the SUs submit their sensing data to the fusion centre without making local decisions, in a hard fusion rule, each SU makes the local binary decision independently of the activity of the PU. Using one of the combining rules, the decision is made at FC [24].

2.0 LITERATURE REVIEW AND FUNDAMENTAL CONCEPT

2.1 Introduction

This section discuss review of fundamental concepts on the improved spectrum sensing method for cognitive radio and related work.

2.2 Dynamic Spectrum Access

Dynamic spectrum access is the idea of finding white spaces or spectrum holes (a frequency range that is available for usage but not fully occupied) and using them for communication. The most important use of cognitive radios is dynamic spectrum access [25].

The SU networks opportunistically access the PU bands, resulting in minimal disturbance to the PUs. Figure 2.1 depicts the dynamic spectrum access (DSA) scenario where several PUs and SUs coexist with their Primary Base Station, PBS and Secondary Base Station, SBS respectively. DSA is a method through which a radio system dynamically adapts to available spectrum holes with restricted spectrum use rights in response to shifting conditions and goals. The produced interference alters the radio's state under environmental restrictions. The primary goal of DSA is to eliminate two types of interference: harmful interference due to faulty devices, and harmful interference as a result of malicious users [25].

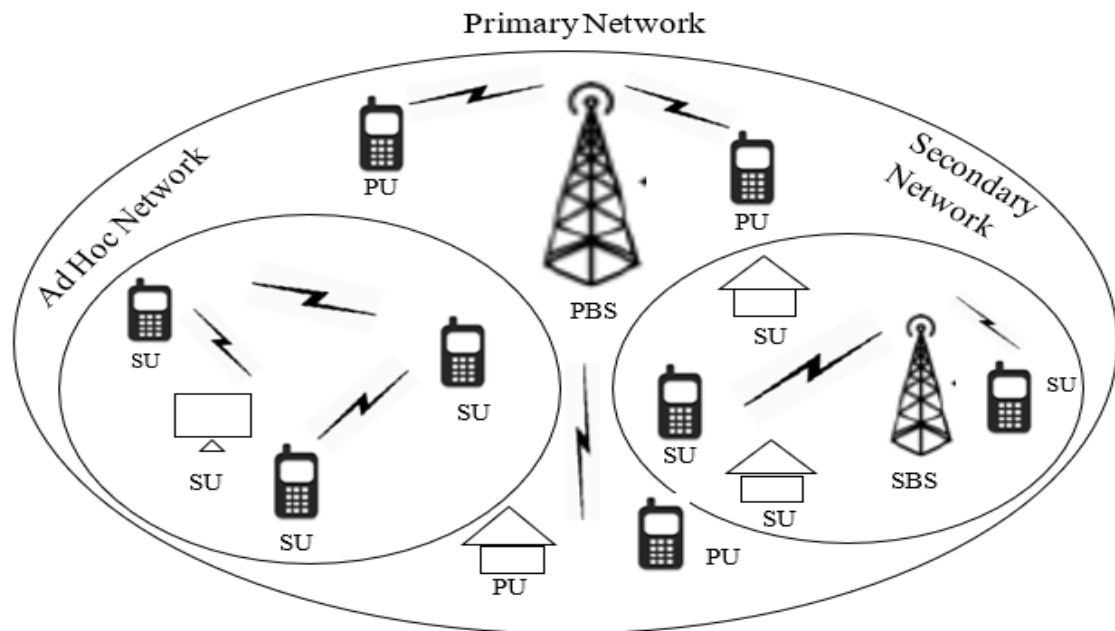

Figure 2.1: Dynamic Spectrum Environment

2.3 Software-Defined Radios (SDR)

According to FCC definitions, an SDR is a radio that has a transmitter and works within commission-approved specifications for frequency range, modulation type, maximum output power, and transmitter conditions. These can be altered by altering the software without altering the hardware parts that control the radio frequency emissions [26]. The primary concept of SDR is, in essence, the capacity of the user to alter transmissions on the run without being constrained by technology.

2.4 Spectrum Sensing Techniques

Energy detection, matching filter detection, and cyclostationary feature detection are the three fundamental methods for spectrum sensing. The hybridization of matched filter detection and cyclostationary feature detection techniques was taken into consideration for this research work. The following sections provide explanations for each technique that made up the hybrid.

2.4.1 Matched Filter Detection, MFD

The matched filter detection is an intelligent sensing technique. This technique needs knowledge of the PU signals at SU beforehand. The SU receives both the signal and the pilot stream if the PU transmitter transmits a pilot stream along with the data. By projecting the received signal in the pilot's direction, matched filter detection is carried out [16]. Convoluting an unknown signal with a time-reversed version of the signal is analogous to this. The operation of the matched filter can be written as [27]:

$$y(n) = \sum_{k=-\infty}^{\infty} h(n-k)x(k) \tag{2.1}$$

Where x is the unknown signal convolved with h (impulse response of matched filter which has been matched to the reference signal) to maximize SNR.

Convolution does two functions i.e. it has placed one function over the other function and generated single value output suggesting a level of similarity. Secondly, it has moved the first function an infinitesimally small distance and found another value.

Demodulation of received signals by SUs is necessary in this scheme. Thus, necessitating requirement of perfect knowledge about PUs signalling features such as bandwidth, operating frequency, modulation type, and pulse shaping and frame format [27].

If the average sum of the signal convolved using Fast Fourier Transform, (FFT) is greater than the threshold (λ), then PU is present or if otherwise, the PU is absent.

2.4.2 Cyclostationary Feature Detection, CFD

Cyclostationary Feature Detector uses the cyclostationary characteristics of the received signals such as their periodicity, number, type of modulation, symbol rate, and presence of interferers. It identification is a spectrum sensing technique for recognising PU signals [28]. The autocorrelation process is used to achieve this strategy. The received signal $y(n)$ can be multiplied with its delay version to calculate the autocorrelation. To identify the activity of the PU signal, the total of autocorrelation is compared with a predetermined threshold. The PU is present if the summation is greater than the threshold; otherwise, it is absent [29]. It takes advantage of the periodicity that is frequently incorporated into the primary signals that are received (such as modulated signals paired with sinewave carriers, cyclic prefixes, hopping sequences, etc.). These cyclostationarity signals exhibit periodic statistics and spectral correlation due to their periodicity, which cannot be seen in stationary noise or interference [27]. By looking at the Cyclic Autocorrelation Function (CAF) of the received signal $x(t)$, it can be achieved as follows:

$$R_{xx}^{\alpha}(\tau) = E[x(t) \cdot x^*(t - \tau) \cdot e^{-j2\pi\alpha t}] \quad (2.2)$$

Where $E[\cdot]$ is expectation operation, $*$ denotes complex conjugate, α is cyclic frequency (CF). However, CAF can also be characterized by its Fourier series expansion called Cyclic Spectrum Density (CSD) function as:

$$S(f, \alpha) = \sum_{\tau=-\infty}^{+\infty} R_{xx}^{\alpha}(\tau) e^{-j2\pi\alpha\tau} \quad (2.3)$$

When cyclic frequency, α , equals fundamental frequency of transmitted signal, peaks have been exhibited by CSD function. This technique can distinguish between the signal and the noise, so it has a better performance as compared to Energy Detection. However, it has a high computational complexity, since it consumes a long sensing time. The detection of the PU signal has been based on scanning the cyclic frequency of its cyclic spectrum or its cyclic autocorrelation function [30]. Comparing the cyclic spectrum or CAF at a given CF with the threshold value, decision can be made about presence/absence of primary signal.

2.4.3 Improved Hybrid Spectrum Sensing Method, IHSM

In the past, many researchers had used various types of hybrid method for spectrum sensing in cognitive radio, particularly the improvement of spectrum sensing performance in cognitive radio using modified hybrid sensing method in [16]. The approach used was the hybrid of matched filter and cyclostationary feature techniques with half sample selection under Rayleigh multipath fading channel. The result shows an improvement in performance detection and reduction in the computational complexity. However, this approach can be improved in terms of sample selection and by using other types of multipath fading channels.

To further improved the detection probability and reduce computational complexity of the CRU, an IHSM detector was proposed, it consists of MFD and CFD detectors. The method involved the use of the quarter of samples under non-fading channel (AWGN) and other type of multipath fading channel (Weibull). Therefore, to know whether the PU is absent or not, the output of the PU transmitter was received by MFD and if the MFD has less or no much information about PU, it handovers to CFD. Unlike a single detector such as MFD or CFD, IHSM can sense the signal more precisely.

2.5 Decision Fusion Rules

Cooperative spectrum sensing techniques fall into three categories: soft combination techniques, hard combination techniques, and two-stage combination techniques [24].

2.5.1 Soft combination schemes:

According to this scheme, SUs send their sensing data to FC without taking any action. Square law combination (SLC), maximum ratio combination (MRC), and double threshold soft decision (DTSD) rule are the primary rules in this detection technique.

Square law combination (SLC): Under this rule, the fusion centre adds the signals from each secondary user before comparing them to a predetermined threshold to determine whether or not PU is present [24].

Maximum Ratio Combination (MRC): In this method, the signals of CR users are added after being multiplied by a normalised weight. The output of this rule is its overall energy.

Double Threshold Soft Decision Rule (DTSD): This technique compares signals using two thresholds. All secondary users communicate their sensing data to the fusion centre as part of the system's operation. At the fusion centre, each signal is compared to the initial threshold of λ_1 . Then, in order to lower the likelihood of a false alarm, the energies below threshold are discarded. The remaining energy are then combined and compared to the second threshold, λ_2 [24].

2. Hard combination schemes:

This scheme involves local decisions made by SUs, which then communicate one binary decision bit to FC. The current regulations are as follows:

AND rule: Under this rule, the FC's ultimate decision is dependent on every local decision that is forwarded to the FC.

OR rule: Under this rule, the FC's ultimate choice is contingent upon any local choice that is forwarded to the fusion centre.

Majority rule: Under this rule, the FC must consider at least half of the local judgements that are forwarded to it [24].

2.6 Wireless Channel Environment

Wireless channels are often referred to as the free space or path between the transmitting and receiving antenna. Depending on the topography, these channels affect the behaviour or characteristics of the sent signal as it travels [31]. These phenomena are what give this signal its characteristics: Signal reflection, refraction, and diffraction caused by objects in between the antennas, there must be a direct line of sight between the antennas, the objects between the transmitter and receiver as well as their relative velocity, noise in the channel and signal attenuation as it passes through the medium.

If the transmitter signal can be correctly modelled in a real-world setting, the received signal can be calculated from the transmitter signal. Scientists and engineers have researched in various environment and given us strategies for simulating those situations in various media that are as near to reality as possible [31]. Detection may be cooperative and non-cooperative. Their performance can be assessed in several channels both fading and non-fading such as AWGN, log-normal, Hoyt (or Nakagami-q), Rayleigh, Rician (or Nakagami-n), Nakagami-m, and Weibull channels [32].

2.6.1 Additive White Gaussian Noise (AWGN) Channel: is the statistically random radio noise that, in terms of signal in communications channel, has a broad frequency range. With the following presumptions, it is the widely accepted model for thermal noise in communication channels [31].

(i) The noise is additive, i.e., the signal received is the addition of signal transmit and some noise. Statistically, the noise is independent of the signal.

(ii) The noise is white, i.e., the power spectral density is flat, so the autocorrelation of the noise in the time domain is zero for any non-zero time offset

(iii) The noise samples have a Gaussian distribution, i.e., the higher the sample the better the result.

Therefore, AWGN channels took place in a non-fading environment, meaning that the signal is free from shadowing or fading effect. The sensing channels are only corrupted with AWGN by reflecting the presence of background noise and other sources of interference that affect signal quality.

2.6.2 Log-normal Shadowing Channel: The log-normal shadowing distribution shows the effects of random shadowing over locations of large number of measurements with different levels of cluster on the path of propagation. The log-normal random variable, where is a zero-mean Gaussian random variable with variance, can be used to describe the linear channel gain. dB-spread is typically used to describe log-normal shadowing [33].

2.6.3 Hoyt (or Nakagami-q) Fading Channel: More severe fading settings than Rayleigh fading are typically described using the Hoyt or Nakagami-distribution [33]. One of the well-liked proposed distribution models is the Nakagami-q. Nakagami introduced this model as a Nakagami-m distribution estimation throughout the range of fading that extends from the one-sided Gaussian model to the Rayleigh model [34].

2.6.4 Nakagami-m Fading Channel: The modelling of physically fading radio channels has seen extensive use of the Nakagami-m distribution. The Nakagami-m fading model's excellent fit to empirical fading data serves as the main argument for use. It is adaptable, and we may model signal fading situations that range from severe to moderate, to light fading, or even no fading, using its parameter m. It is adaptable and can represent signal fading situations that range from

severe to moderate, to light fading, or even no fading thanks to its parameter m . As particular examples, it contains the one-sided Gaussian distribution ($m = 0.5$) and the Rayleigh distribution ($m = 1$) [35].

2.6.5 Rayleigh Fading Channel: If there are many plane waves and many forms of scattering present in the environment, the signal amplitude will follow a Rayleigh distribution [36]. It is a statistical model that assumes that the signal is composed of many random components that have equal magnitude and phase that lead to multiple reflections and scattering of the signal by various obstacles. When there is no direct line-of-sight path, multipath fading is usually modelled using the Rayleigh distribution [35].

2.6.6 Rician (or Nakagami-n) Fading Channel: There is a specular or LoS (Line of Sight) component to certain kinds of scattering situations. The received signal amplitude in this instance has a Rician distribution [33]. Modelling propagation paths with one strong direct LOS component and numerous random weaker components frequently employs the Rician distribution [35].

2.6.7 Weibull Fading Channel: In the real-world systems, it is common for signals to be transmitted through various channels that introduce impairments and distortion. One such scenario involves the uses of a Weibull fading channel, which add a level of realism to signal propagation. [36] The Weibull fading channel accounts for the effects of multipath propagation, where the signal encounter multiple paths with different delays and attenuations. This lead to fluctuations in the received signal strength over time, resulting in fading.

The Weibull distribution is employed in many scientific disciplines nowadays. It is a highly popular statistical model, for instance, in failure data analysis and reliability engineering. While it is commonly employed in radar systems to represent the dispersion of the received signal level created by particular types of clutters, it is also used in other applications, such as weather forecasting and data fitting of all kinds [36]. In terms of wireless communications, the experimental fading channel measurements for both indoor and outdoor situations seem to correspond well with the Weibull distribution, with a plausible physical basis provided in [37].

For the purpose of this research work, AWGN and Weibull channels were the two wireless channels considered. For the purpose of this research work, AWGN and Weibull channels were the two wireless channels that was considered. The choice of these channels was as a result of the fact that:

1. Weibull distribution is particularly adaptable in both indoor and outdoor communication situations and environments.
2. In urban communication environments, if the Rayleigh distribution fails as in digital enhanced cordless telecommunications (DECT) system, Weibull distribution have the capability of accounting for the propagation [38].
3. In spite of the effectiveness of the distribution, however, the work related to IHSM in the literature for cooperative and non-cooperative scenario over Weibull fading condition is not reported.

2.7 Fast Fourier Transform

A sequence $x(n)$ is transformed into a sequence $X(k)$ in the frequency domain using the N -point Discrete Fourier Transform (DFT). An N -point DFT must be directly computed by doing $N \times N$ complex multiplications and $N(N - 1)$ complex additions. Numerous strategies were created to cut down on the required calculations [39]. The Fast Fourier Transform (FFT), a technique created by Cooley and Turkey, is the most well-known of these. The FFT can be viewed as an algorithm (or a technique) for quickly (with fewer calculations) computing the DFT. Here the computational efficiency is attained by adopting a divide and conquer approach. An N -point DFT is decomposed into progressively smaller DFTs in this approach, which are then combined to produce the final transform. A set of computational algorithms known as FFT algorithms was created based on this fundamental approach which was adopted for this work [39].

As a result of this fundamental approach, a set of computational algorithms were developed and are collectively known as Fast Fourier Transform, FFT algorithms, which was adopted for this work [39].

REVIEW OF RELATED WORK

Authors of [13], proposed hybrid spectrum sensing method for cognitive radio based on the Centralised Coordination concept, and it considers the deployment of infrastructure for CR users. The CR controller, which can be a wired stationary device, is notified once CR detects the existence of a primary transmitter. Using a broadcast control message, the CR controller notifies all CR users within its coverage area. The most reliable spectrum sensing mechanism is produced by this networking dilemma using the centralised concept of spectrum sensing. Numerous cutting-edge techniques, such as cooperative spectrum sensing, interference management, cognitive radio reconfiguration management, and distributed

spectrum sensing communications, must be used in conjunction with one another. Additionally, it offers quick, dependable operation and accurate system interference identification. Increasing the spatial and spectral diversity will increase the throughput of secondary nodes. More importantly, the approach utilised for efficient radio frequency spectrum utilisation should identify the interference, so that the primary user will not experience interference from a CR system when using their licenced spectrum. This method does also resolve the computational complexity issue.

Improvement of Spectrum Sensing Performance in Cognitive Radio using Modified Hybrid Method of Sensing in [16], for both cooperative and non-cooperating situations, it comprises of a Match Filter and a Cyclostationary Detection method. This method is based on a matching filter that receives half of the PU signal samples, senses the signal, and then forwards it to cyclostationary feature detection if sufficient knowledge of the signal is not known. The findings demonstrate that the suggested method reduced computational complexity and improved spectrum sensing detection performance in cognitive radio. This approach was carried out and assessed using Additive White Gaussian Noise (AWGN) and Rayleigh fading channels. However, this method can be further improved by employing other multipath fading channels and by using other methods of sample selection.

A low-complexity cyclostationary-based detection method for cooperative spectrum sensing in cognitive radio networks is the subject of the research presented in [17]. It is a hybrid detector, which combines cyclostationary and energy detection techniques. An energy detection (ED) is employed for high SNR regions, whereas a cyclostationary detection is used in low SNR regions. Due to ED's straightforward structure and minimal computational complexity when compared to frequency domain, the cyclostationary detector (CFD) is utilised in the time domain. The effectiveness of the suggested hybrid method for Cooperative Spectrum Sensing (CSS) is evaluated and compared with that of purely CFD- and only ED-based schemes. It was observed that implementing full cyclostationary detection at all CRUs would be complicated but would enhance performance over ED. The cooperative scenario increases the effectiveness of the suggested methods. Nevertheless, using double threshold and other fading channel types in the sensing process can help to increase the probability of detection and reduce computational complexity.

The work done in [23], investigated the complexity reduction of cyclostationary sensing technique using improved hybrid-sensing method using the Fast Fourier Transform, FFT and Sliding Discrete Fourier Transform, SDFT. A novel approach the performance of CR in terms of detection performance in cooperative and non-cooperative scenarios under AWGN and Rayleigh multipath fading channels. The performance was evaluated and compared using energy detection, traditional and hybrid methods available in literature. The proposed methods reduce the computational complexity by using only a half number of samples in the autocorrelation process and using the SDFT in the second proposed method with a little loss in the detection performance. The proposed methods become more efficient when the cooperative scenario is assumed. Nevertheless, in order to improve the probability of detection, this technology can be modified by using double threshold in the sensing process along with different types of fading channels. More so, the transmission stage and selecting the right coding schemes might be taken into account.

Furthermore, the method in [24] suggested two-stage detection rules to increase throughput in cognitive radio networks. This method employs three decision rules, each of which has two decision stages (hard and soft), and is proposed to increase CR throughput in cooperative scenarios. The credibility of the decisions and throughput can both be increased by using mixed types of decision rules. The performance of three modified mixed-type decision rules over noisy and Rayleigh multipath channels has been examined and compared to other mixed rules available in the literature. The proposed rules create a special criterion to reduce computations based on the value of detection probability in addition to blending the soft and hard rules. The cooperative scenario increases the effectiveness of the suggested methods. However, using double threshold and other fading channel types in the sensing process can help to reduce the latency leading to increase the probability of detection and reduce computational complexity.

A Deep Neural Network Model for Hybrid Spectrum Sensing in Cognitive Radio in [40] presents the artificial neural network (ANN)-based hybrid spectrum sensing (HSS) technique. ANN is used to aggregate several Test Statistics (TSs) from various detectors rather than employing a single detection method as is the case with traditional spectrum sensing. The employed detectors' TSs for the noise-only scenario and the case where PU is active are used to train the ANN system. The numerical outcomes support the suggested HSS's effectiveness in comparison to the non-hybrid detection technique, which trains the ANN with the TS on just one detector. The findings also demonstrated that when the number of detectors rises, the accuracy of the detection outcome increases. The proposed ANN-based HSS performs better than the traditional ANN-based energy detector and proves its capacity to detect PU signal at very low SNR, which is supported by numerical findings. The system, however, was unable to withstand a reduction in computational complexity.

According to the research in [41], a multi-path hybrid spectrum sensing scheme for cognitive radio was presented to increase sensing efficiency. The proposed approach combines two conventional sensing schemes; energy detection and maximum minimum eigenvalue detector in a hybrid scheme. Additionally, performance analysis is done to highlight the performance trade-offs for the suggested sensing system in terms of detection performance and mean detection time. The primary goal of this successfully completed and assessed work is to maximise the detecting probability under the existing false alarm probability limits without increasing the computational cost. However, the emphasis is on proving the effectiveness of the proposed hybrid approach to improve sensing performance and address the issue of inadequate spectrum utilisation. However, based on the findings of this study, further research work such as testing the proposed hybrid model in a cooperative sensing scenario and determining how it affects the efficiency of cooperative sensing need to be done.

The research in [42] proposed using a hybrid matched filter with a single cycle cyclostationary feature detector for spectrum sensing for cognitive radio. The two together improve the ability to find such an architecture. This leads to great frequency offset tolerance as well as precise phase-unknown signal recognition in settings with very low SNR. The proposed method outperforms Hybrid Matched Filter in terms of detection probability and false alarm rate, according to simulation findings. However, the signal processing associated with the cascaded steps of the proposed approach results in a large execution time overhead. Therefore, it would be interesting to reduce latency of the proposed scheme's execution time.

The study of the two sensing methods, Energy detection and CFD, has also been done, as shown in [43], and from this hybrid model, proper spectrum utilisation is intended. The hybrid method improves the network's efficiency. The outcome from the proposed method has been contrasted with earlier methods for the network's improved efficiency in terms of energy consumption and throughput. Although this approach reduced the amount of processing power used, reduced the sensing period, and improved throughput and error, but unable to address the issue of computational complexity.

In the like manner, [44] employed a technique for energy efficiency in cognitive radio networks based on cooperative spectrum sensing and hybrid spectrum handoff. The study offers a second priority user transmission system that senses available channels through cooperative spectrum sensing. Energy efficiency is achieved by optimising the energy consumption of the sensing process. For spectrum mobility management, a threshold technique based on primary user traffic patterns is provided. Calculation of probabilistic stay-and-wait and Quality of Service (QoS) handoff values is done using a threshold technique. Using a hybrid handoff technique based on dynamic spectrum aggregation, the transmission channel is chosen. In order to determine the best channel with the highest throughput and lowest energy consumption, a cooperative spectrum sensing algorithm is defined and simulated. However, this research work can be further improved by taking into account the additional unoccupied spectrums that are accessible for transmission but are not utilised, resulting in greater energy usage. Additionally, a method is required to communicate or share accurate information about channels amongst SPUs. The other SPUs utilise energy by constantly detecting the occupied channel because malicious users may continue to exploit spectrum gaps and spread false information about them.

The work done in [45], present a novel design of Improved Hybrid Spectrum Sensing Technique for Cognitive Radio Network. It is a performance evaluation of a hybrid spectrum sensing method based on spectral covariance sensing and energy detection (ED). Performance measures include sensing time, SNR, and probability of detection. Numerical findings from computer simulation and analytical formulation show that the proposed hybrid spectrum sensing offers superior detection at low SNR, when the energy detector is unreliable. In addition, the results demonstrate that for the majority of the SNR range, the suggested spectrum sensing technique's mean detection time is significantly lower than that of the Spectral Covariance detection technique. Therefore, the suggested method offers a reasonable balance between performance and detection time. To further improved outcomes, the proposed technique can be used in conjunction with other computational techniques.

In order to choose an appropriate spectrum band for cognitive users, the authors in [46] developed a Hybrid Spectrum Sensing Approach to Select Suitable Spectrum Band for Cognitive Users. This method uses an energy detector with an interweaving approach to proposed a cooperative spectrum sensing method. The accuracy of the sensing results is improved by using low-energy clustering techniques and an anticipated maximisation algorithm. Through the identification of the appropriate spectrum using historical environmental variables, reinforcement learning enhances performance spectrum management. The findings demonstrate that the suggested technique has a greater level of spectrum sensing accuracy, and that the CU can select the ideal spectrum hole. The system will then offer CR users an alternative after the PUs have filled the designated spectrum hole. Yet, this method takes maximum estimation time. It can be further enhanced by reducing its latency to find the ideal spectrum hole in a known RF environment in less estimating time without interfering with the PUs.

Hybrid Spectrum Sensing Using MD and ED for Cognitive Radio Networks was the approach used in [47]. To identify the spectrum hole from the available spectrum resources, the hybrid detector (HD) is proposed. An energy detector (ED) and matched detector (MD) serve as the foundation for HD design. HD is able to sense the signal more precisely than a single detector. Whether or not the primary user (PU) information is available in this case, HD can function under both circumstances. HD is examined in a variety of situations, both with and without the use of CSS (cooperative spectrum sensing). In order to implement OR, AND, and majority schemes for CSS with low SNR barriers, four users were used. The method, meanwhile, was unable to handle PU signals with low SNR and could not minimize its computational complexity.

Hence, the detection performance of spectrum sensing techniques and its computational complexity challenges in the above-related work was the focus of this work. These challenges were ameliorated by the current improved hybrid spectrum sensing method (IHSM) based on matched filter detection and cyclostationary feature detection. The current proposed research work adopts similar approach as in [16] but with variation in terms of sample selection and by using AWGN and Weibull type of fading channels in cooperative and non-cooperative scenarios. The procedure of this method is such that the matched filter receives the licensed user signal and senses the samples by selecting one quarter and skipping the rest. This method improves the detection performance of the MFD, when it has enough information about the licensed user signal. It also reduces the computational complexity of the CFD performance detection process.

3.0 SYSTEM MODEL

The system model is subdivided into the following subheadings:

3.1 The Design Model of the IHSM

The proposed sensing method used was an improved hybrid spectrum sensing method, IHSM for cognitive radio networks. The design is based on the hybridization of matched filter detection and cyclostationary feature detection techniques, with the hope to improve the probability of detection and reduce its computational complexity. In this concept, a band pass filter with a bandwidth, W is used to pre-filter the received signal. The output of this filter is fed into the hybrid detector, where FFT convolution and autocorrelation were performed, before being routed through the AWGN or Weibull channels. The outcome are measured against a predetermined threshold value, λ .

The method yield high result in performance detection and reduction in computational complexity of spectrum sensing for cognitive radio networks. The block diagram is shown in Figure 3.1.

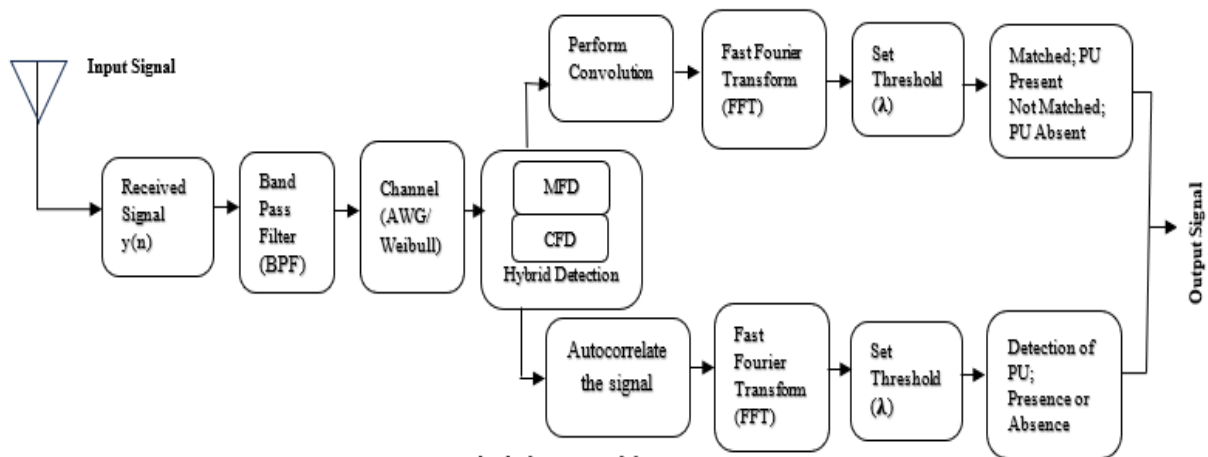

Figure 3.1: Block diagram of the IHSM

3.2 Computational Complexity of the IHSM

Here, the computational complexity was done at MFD and CFD stages. The computing complexity of the convolution process based on the frequency domain in the first stage is equal to the multiplication of two signals since the MFD is based on the convolution process between the received and prior information of the PU signal. Additionally, the received PU signal's impulse and its frequency domain transformation are computed. In other words, the convolution of the input

signal received $x(n)$ and the MFD impulse response, $h(n)$, can be used to identify the output signal of the PU received by SU, $y(n)$, at a specific moment in time, such as $t = t_0$. Thus

$$y(n) = x(n) * h(n) = \sum_{k=-\infty}^{\infty} x(k) h(t_0 - k) \quad (3.1)$$

The test statistic the matched filter detection, T_{MFD} can be written as [16]:

$$T_{MFD} = \sum_N y(n) x^*(n) \quad (3.2)$$

Where $x^*(n)$ represents the conjugate of PU signal (cognitive PU pilot-stream).

The activity of PU is then determined by comparing the T_{MFD} to a predetermined threshold, as illustrated in Equations (3a and 3b) [16].

$$\text{If } T_{MFD} \geq \lambda, \text{ PU signal is present} \quad (3.3a)$$

$$\text{If } T_{MFD} < \lambda, \text{ PU signal is absent} \quad (3.3b)$$

The Discrete Fourier Transform

(DFT) is commonly referred to as N-point DFT and is described in terms of the number of samples, N.

A finite duration sequence $x(n)$ of length L (where $N \geq L$) has the following N-point DFT [39]:

$$\text{DFT } \{x[n]\} = X[k] = \sum_{n=0}^{N-1} x[n] W_N^{nk} \quad (3.4)$$

For $k = 0, 1, 2, \dots, N-1$.

Also, the Inverse Discrete Fourier Transform (IDFT) of the sequence $X[k]$ of length N, is given as [39]:

$$\text{IDFT } \{X[k]\} = x[n] = \frac{1}{N} \sum_{k=0}^{N-1} X[k] e^{j2\pi nk/N} = \frac{1}{N} \sum_{k=0}^{N-1} X[k] W_N^{-nk} \quad (3.5)$$

For $k = 0, 1, 2, \dots, N-1$

$$\text{Where } W_N = e^{-j(2\pi/N)} \quad (3.6)$$

W_N is called the Twiddle Factor. It is a major key component in the pursuit of simplicity and optimization in the computation DFT and IDFT [39].

Fast Fourier Transform, FFT algorithm is used to compute the DFT efficiently by adopting the divide and conquer approach. In addition, the computation of N-point DFT requires $N \times N$ complex multiplications and $N(N-1)$ complex additions. By direct computation of all DFT coefficients requires $o(N^2)$ operations, while the FFT algorithm computes all DFT coefficients with $o(N \log_2 N)$ operation for N to a power of 2.

Hence, the computational complexity of FFT for N sample is $o(N \log_2 N)$ and when two sample are multiplied each with N samples, the result is $o(N)$ [16].

The computational complexity of a conventional MFD. CC_{mfdFFT} is given as:

$$CC_{mfdFFT} = 2o(N \log_2 N) + o(N) \quad (3.7)$$

Since quarter number of sample ($N/4$) was taken, the IHSM computational complexity of a conventional MFD becomes:

$$CC_{mfdProposed} = 2o\left(\frac{N}{4} \log_2 \frac{N}{4}\right) + o\left(\frac{N}{4}\right) \quad (3.8)$$

The CFD procedure is based on the autocorrelation process and its computational complexity in the second stage [39]. The autocorrelation $R_{xx}(n)$ of the PU signal $x(n)$ with its shifted version $x(-n)$ is give as:

$$R_{xx}(n) = x(n) * x(-n) \quad (3.9)$$

If a signal's autocorrelation is a periodic function of time t with a specific period, the signal is said to be cyclostationary. A 2nd order cyclostationary detector is the name given to this kind of cyclostationary detector. The definition of a discrete cyclic autocorrelation function for a discrete-time signal $x(n)$ with a fixed lag l is given as [17].

$$R_{xx}^\alpha(l) = \lim_{N \rightarrow \infty} \frac{1}{N} \sum_{m=0}^{N-1} x[m] X^*[m+l] e^{-j2\pi \alpha m \Delta m} \quad (3.10)$$

Where N is the number of samples of a signal $x[n]$ and Δn is the sampling interval. By applying the discrete Fourier transform to,

$$R_{xx}^{\alpha}(l),$$

the cyclic spectrum (CS) is given as (3.11) [16]:

$$S_{xx}^{\alpha}(f) = \sum_{l \rightarrow \infty} R_{xx}^{\alpha}(l) e^{-j2\pi f l \Delta n} \quad (3.11)$$

By measuring the (cyclic frequency) of the PU signal's cyclic spectrum or cyclic autocorrelation function (CAF), the PU signal can be detected. The signal is present if the CAF is greater than the pre-defend threshold; else, the signal is absent [29].

To find a signal hidden in noise, correlation is a powerful tool. Therefore, the complexity of a traditional cyclostationary feature detection technique, $CC_{cfdfFFT}$ is the summation of computational complexity through the autocorrelated process CC_{auto} and computational complexity when converted to frequency domain, CC_{freq} as shown in Equation (3.10)[17]

$$CC_{cfdfFFT} = CC_{auto} + CC_{freq} \quad (3.12)$$

Autocorrelated process CC_{auto} is the summation of the number of real multiplications, R_m and number of real additions, R_a .

$$CC_{auto} = R_m + R_a = 4N + (4N - 2) = 8N - 2 \quad (3.13)$$

Computational complexity when converted to frequency domain, CC_{freq} is:

$$CC_{auto} = R_m + R_a = 4N + (4N - 2) = 8N - 2 \quad (3.13)$$

Combination of (3.13) and (3.14) gives the computational complexity of a conventional cyclostationary process as (3.15)

$$CC_{cfdfFFT} = 8N - 2 + o(N \log_2 N) \quad (3.15)$$

But, the IHSM scheme, only select a quarter of the samples for the cyclostationary process the Equation (3.15) reduces to:

$$CC_{cfdfProposed} = 2N - 2 + o\left(\frac{N}{4} \log_2 \frac{N}{4}\right) \quad (3.16)$$

The total computational complexity of the IHSM proposed, $CC_{ihsmProposed}$ is the addition of Equations (3.8) and (3.16), as shown in Equation (3.17).

$$CC_{ihsmProposed} = 2N - 2 + 3o\left(\frac{N}{4} \log_2 \frac{N}{4}\right) + o\left(\frac{N}{4}\right) \quad (3.17)$$

The computational complexity ratio is defined as the ratio of computational complexity in the proposed method to the maximum computational complexity in the conventional Cyclostationary method (3.18).

$$CC_{ratio} = \frac{CC_{ihsmProposed}}{CC_{cfdfFFT}}$$

$$CC_{ratio} = \frac{2N - 2 + 3o(N/4 \log_2 N/4) + o(N/4)}{8N - 2 + o(N \log_2 N)} \quad (3.18)$$

3.3 Probability of Detection of IHSM

The probability of detection of this method involves utilizing various parameters at both matched filter detection and cyclostationary feature detection stages.

At MFD stage, the probability of detection $P_{d,MFDi}$ is given as [8]:

$$P_{d,MFDi} = \frac{\lambda - E}{\sqrt{E \sigma_n^2}} \quad (3.19)$$

Where λ is the threshold, σ_n^2 is the noise variance and

$$E = \sum_{n=1}^N x(n)^2 \quad (3.20)$$

At CFD stage, the probability of detection over the channels is given as [21]

$$P_{d,CFDi} = Q\left(\frac{\sqrt{2}\Omega}{\sigma}, \frac{\lambda}{\sigma_n}\right) \quad (3.21)$$

Where Ω is the instantaneous SNR, σ^2 is the SUs variance. $Q(\dots)$ is the Marcum Q-function

By default, the instantaneous SNR is an analogue signal. The power of this signal can be represented in digital form as $\frac{E_b}{N_o}$.

Hence,

$$\frac{E_b}{N_o} = \left(\frac{S}{N}\right) X \left(\frac{W}{R}\right) \tag{3.25}$$

Where (S/N) is the Signal to Noise Ratio and (W/R) is the Processing Gain

There $\frac{E_b}{N_o}$ is the ratio of energy per bit to the noise power spectral density. It is referred to as signal to noise ratio per bit. It is the measure of signal to noise ratio for a digital communication system [49].

Hence, (3.21) can be written as

$$P_{d,CFDi} = Q\left(\frac{\sqrt{2\left(\frac{E_b}{N_o}\right)}}{\sigma}, \frac{\lambda}{\sigma_n}\right) \tag{3.26}$$

The probability of detection of the IHSM model can be written as in [15]:

$$P_{d,IHSMi} = 1 - (1 - P_{d,MFDi})(1 - P_{d,CFDi}) \tag{3.27}$$

Where $i = 1, 2, \dots, k$, and

k is the number of SUs in cooperative and non-cooperative Scenarios.

3.4 Non-Cooperative Secondary Users Scenario of the IHSM model

In non-cooperative spectrum sensing, each cognitive radio senses the PU independently to carry out frequency band occupancy and unused frequency band detection. The individual sensing SUs base their decision on the signals they are able to detect from the PU transmitter to the PU devices. To assess the activity of the PU signal, a single SU is utilised, which is a single sensing approach. They frequently assume that the PU is aware of the main transmission region. Each of the five SUs lacks a thorough understanding of its coverage area's spectrum retention. This resulted in hasty generalization and conclusion of the absent or present of the primary user, PU. Therefore, it is impossible to completely avoid harmful interference with the licensed PU.

3.5 Cooperative Secondary Users Scenario of IHSM Model

Due to fading, shadowing and other limitations, detection performance is impaired in a non-cooperative setting. Therefore, it may not be very reliable for a single SU or CRU to identify the PU signal in a Cognitive Radio Network. to the fusion centre (FC), which makes a final determination regarding the status of the PU [21]. The AND rule of fusion is used in this situation. In accordance with this guideline, if all SUs report the existence of PU, the presence of PU is approved overall. Hence, Cooperative Spectrum Sensing (CSS) is employed to solve these detection issues. CSS enhances performance by taking use of spatial diversity. Individual CRU in CSS detect the spectrum and send it. Here, in the cooperative scenario, multiple SUs are used to sense the activity of PU signal. As illustrated in Fig. 3.2, assuming there are n SUs (let's say 5 of them) between the PU and FC. It is assumed that each secondary user independently performs local signal sensing and reports these signal values to the FC across a reporting channel in cooperative cognitive radio network. Therefore, the effect of fading is minimized. The proposed system model using the centralised cooperative sensing network is shown in Fig.3.2.

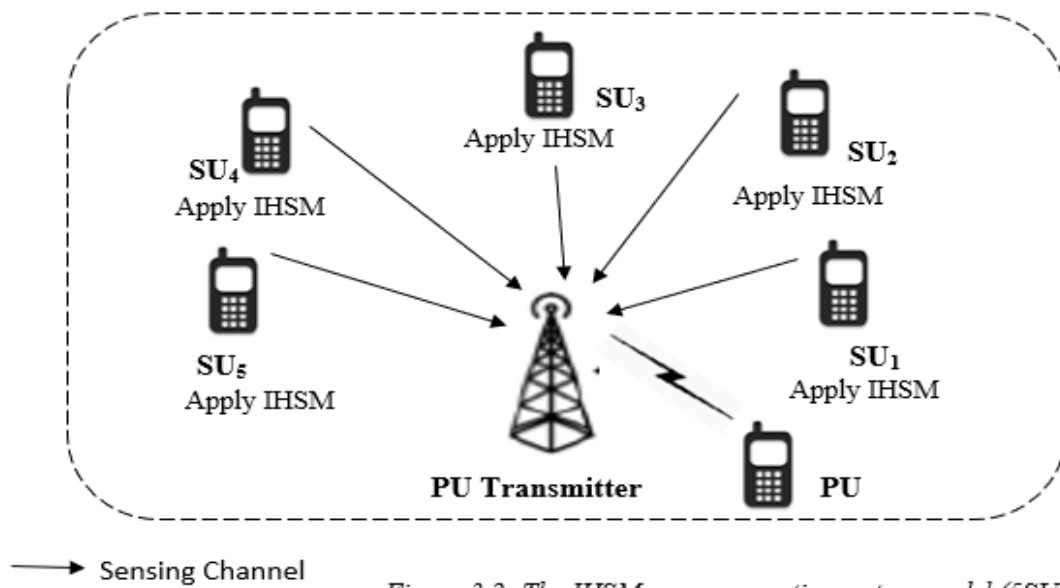

Figure 3.2: The IHSM non-cooperative system model (5SUs)

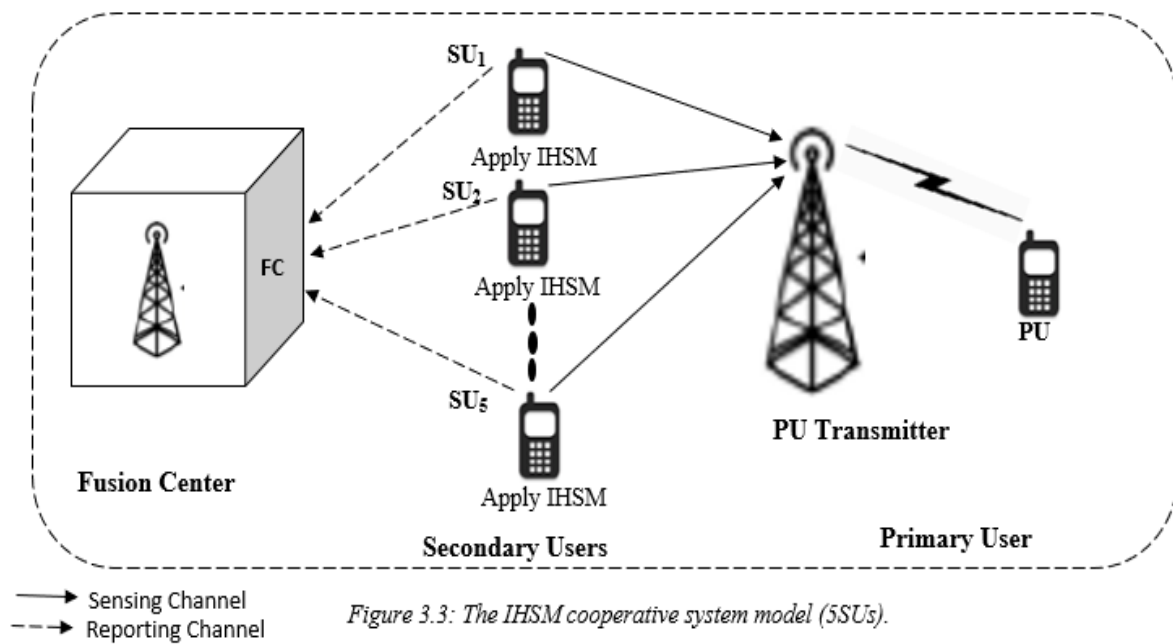

Figure 3.3: The IHSM cooperative system model (5SUs).

Figure 3.4, presents the flowchart that explains the step-by-step procedure of the IHSM.

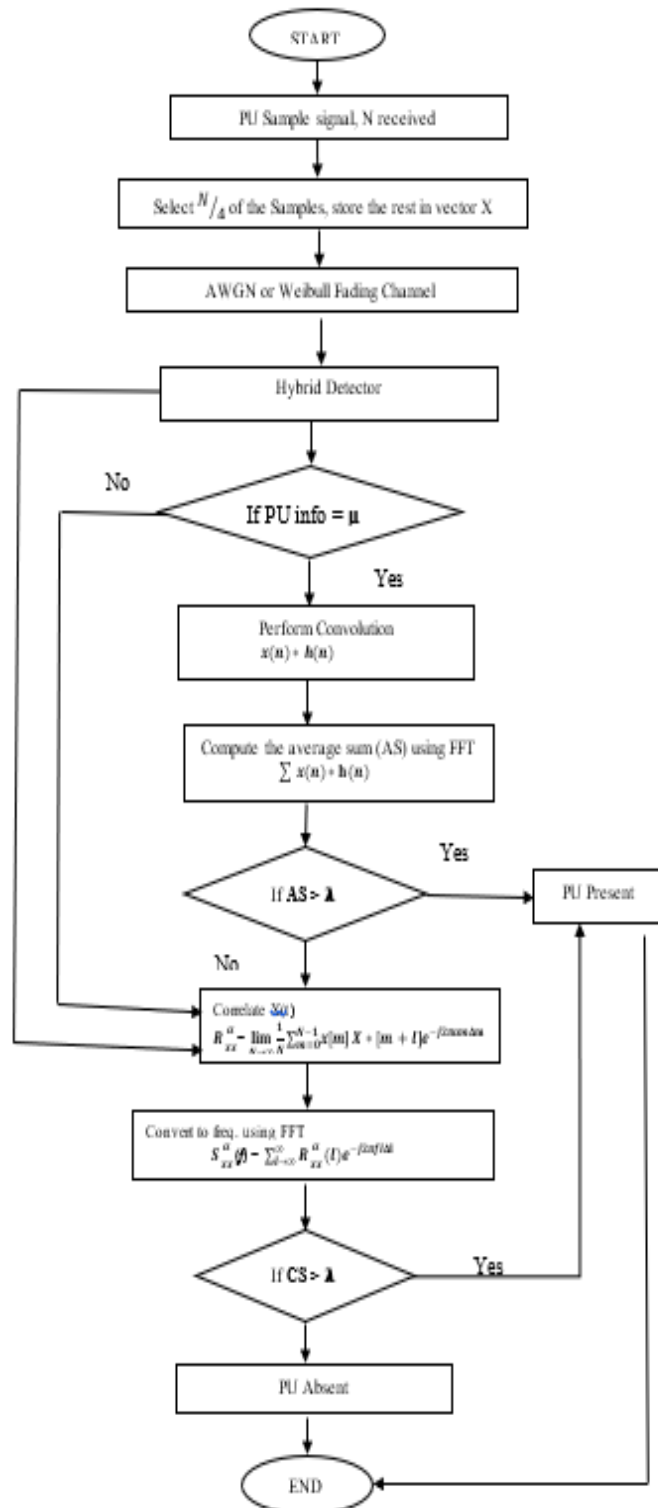

Figure 3.4: Flowchart of the IHSM

3.6 Performance Percentages of the IHSM

The performance percentages include the percentage improvement in the detection performance and percentage reduction in computational complexity of the IHSM model.

3.6.1 Percentage Improvement of Probability of Detection, P_d

In computing the percentage improvement in detection performance of the simulated results, particularly when comparing two curves at the same $\frac{E_b}{N_o}$, it is ensuring that the curves must have different values i.e. high and low probability of detection values. The highest value is taken as the reference point (usually the proposed method curve) as compare to others.

To know the improvement percentage, the differences is obtained and multiply by 100%. Hence, the calculation for the percentage improvement in the simulation result can be obtained using the relationship:

$$\text{Percentage value of } P_d = P_d \times 100\% \quad (3.28a)$$

$$\text{IHSM Percentage Improvement in MFD} = (P_d \text{ IHSM} - P_d \text{ MFD}) \times 100\% \quad (3.28b)$$

$$\text{IHSM Percentage Improvement in CFD} = (P_d \text{ IHSM} - P_d \text{ CFD}) \times 100\% \quad (3.28c)$$

3.6.2 Percentage Reduction of the Computational Complexity Ratio, CC_{ratio}

The percentage reduction in computational complexity of the IHSM at any given number of sample N is the differences between the CC_{ratio} curves of the proposed method and that of MFD or CFD multiply by 100% as

$$\text{Percentage value of } CC_{ratio} = CC_{ratio} \times 100\% \quad (3.29a)$$

$$\text{IHSM Percentage Reduction in MFD} = (CC_{ratio} \text{ MFD} - CC_{ratio} \text{ IHSM}) \times 100\% \quad (3.29b)$$

$$\text{IHSM Percentage Reduction in CFD} = (CC_{ratio} \text{ CFD} - CC_{ratio} \text{ IHSM}) \times 100\% \quad (3.29c)$$

4.0 RESULTS AND DISCUSSION

This section discussed the simulation procedures, parameters, results and its analyses.

4.1 Simulation

There are various numbers of multipath components of the ITU Channel Model for Indoor and Outdoor. The multipath fading used is ITU indoor channel model (A) with the specification shown in Table 4.2 [49].

Table 2.1: ITU Channel Model for Indoor Office

Tap	Channel A		Channel B		Doppler Spectrum
	Relative Delay (ns)	Average Power (dB)	Relative Delay (ns)	Average Power (dB)	
1	0	0	0	0	Flat
2	50	-3.0	100	-3.2	Flat
3	110	-10.0	200	-7.6	Flat
4	170	-18.0	300	-10.8	Flat
5	290	-26.0	500	-18.0	Flat
6	310	-32.0	700	-25.2	Flat

The following procedures are used to obtained the simulation results

- (i) Creating QPSK modulation as a PU signal.
- (ii) Divide the sample signal into four, select a quarter number of the samples and skip the rest.
- (iii) Adding a channel, which is an AWGN channel or ITU indoor channel model (A), Weibull fading channel.
- (iv) Applying the IHSM sensing methods shown in the previous sections.
- (v) There are two scenarios for the sensing process, the non-cooperative and cooperative scenario with multiple SUs.
- (vi) Testing the sensing performance by computing the probability of the detection in equations (3.28a-c) under various values of $\frac{E_b}{N_o}$ of PU signal. In the two-case scenario, the average probability of the detection over all SUs is computed.
- (vii) Also, testing the computational complexity by computing the computational complexity ratio in equations (3.29a-c) under various values of PU signal sample, N from plotted results that were obtained.

The simulation parameters used are presented in Table 4.2.

Table 4.2: Summary table for simulation parameters

S/N	Parameters	Values
A	Computer System	
1	Make and Model	HP Probook
2	Processor	Core i3
3	Processor Speed	2.4 GHz
4	Memory	4 GB RAM
5	Operating System	Window 8.1
	Simulation Software	
1	Matlab	Version 2023
	Simulation Parameter	
1	PU Signal Bandwidth	6 MHz
2	Sensing Time	1 μ s
3	Modulation Type	QPSK
3	Channel Condition	AWGGN, Weibull
4	E_b/N_o Range	1dB to 10dB
5	Number of Sus	1 to 10
6	F_c	200 Hz
7	F_s	4000 Hz
8	P_f	0.001
9	Iteration	10
10	Average PU Occupancy Rate	75%

Note that designers are allowed to choose any detection technique, including energy detection, matched filter detection, cyclostationary feature detection, covariance-based detection, etc., as long as it complies with the IEEE 802.22 WRAN standards. While the fine-sensing time for the spectrum sensing approaches can be on the order of milliseconds (for example, 25 ms) at moderate and high SNRs, they perform poorly at low SNRs. IEEE 802.22 restricts the maximum detection delay to 2 seconds, which may include sensing time and subsequent processing time, despite the fact that increasing the sensing duration enhances performance. At low-SNR spectrum sensing, this time constraint is crucial [50]

Simulation Results

The performance curves of the MATLAB simulated results of conventional spectrum sensing techniques (MFD and CFD) and IHSM scheme in non-cooperative and cooperative scenarios under AWGN and Weibull fading channels are depicted in Figures 4.1a - 4.4.

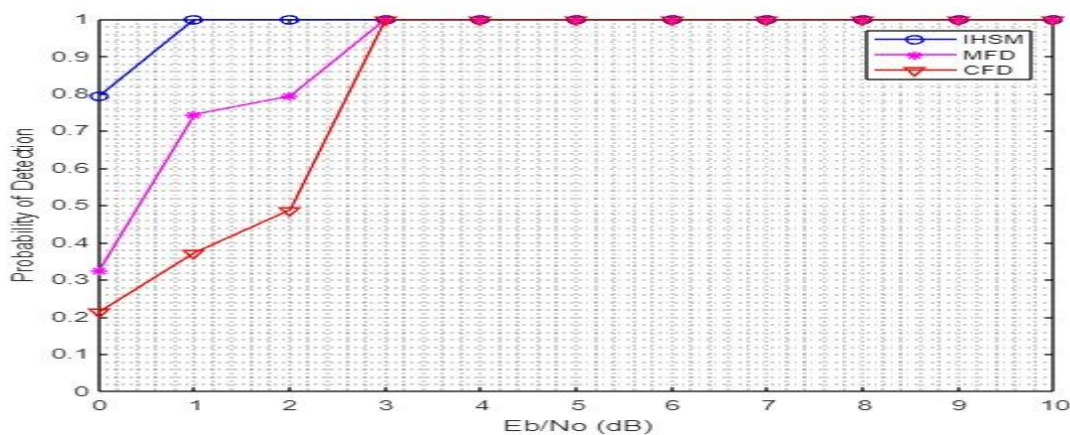

Figure 4.1a. Performance curves of conventional sensing techniques and IHSM under AWGN in non-cooperative scenarios.

From Equations (3.28a-c), the probability of detection values of IHSM, MFD and CFD at $\frac{E_b}{N_o}$ equal to 0 dB are 0.80, 0.32 and 0.22 respectively. Hence, the probability of detection of IHSM is increased by 48% and 68% as compared to MFD and CFD, respectively.

However, at $\frac{E_b}{N_o} = 3\text{dB}$ their probability of detection became the better and same in the detection performance. The IHSM performs best when compared to the MFD and CFD techniques, especially for low values of $\frac{E_b}{N_o}$, as can be shown from the Figure 4.1a.

The MFD technique outperforms the CFD method because it has a better understanding of the PU signal.

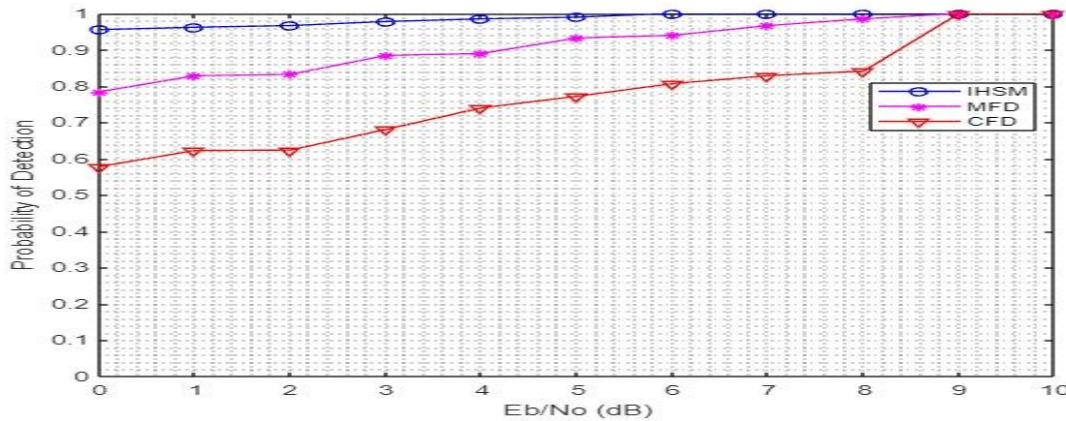

Figure 4.1b. Performance curves of conventional sensing techniques and IHSM under AWGN in cooperative scenarios.

From Equations (3.28a-c), at $\frac{E_b}{N_o}$ equal to 0 dB, the probability of detection values of IHSM, MFD and CFD are 0.96, 0.78 and 0.58 respectively. Hence, the probability of detection of IHSM is increased by 16% and 36% as compared to MFD and CFD, respectively.

It is observed from the Figure that the performance is highly improved and all the methods performed better as compared to Figure 4.1a.

However, the performance of MFD becomes very bad when the knowledge of PU signal becomes poor and the CFD technique becomes the better technique in the detection performance. The performance curves, P_d increases as $\frac{E_b}{N_o}$ increases.

Table 4.1 show the summary of IHSM, MFD and CFD at $\frac{E_b}{N_o} = 0$ under AWGN channel in non-cooperative and cooperative scenario.

Table 4.1 show the summary of IHSM, MFD and CFD at $\frac{E_b}{N_o} = 0$

CHANNEL TYPE	SCENARIO	PROBABILITY OF DETECTION AT $E_0/N_0 = 0$		
		IHSM	MFD	CFD
AWGN	Non Cooperative	0.80	0.32	0.22
		80%	32%	22%
AWGN	Cooperative	0.96	0.78	0.58
		96%	78%	58%

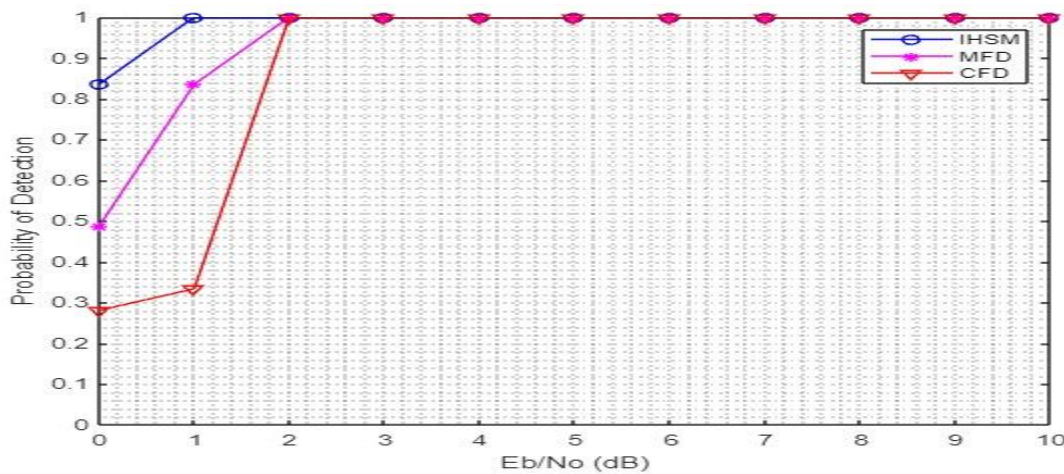

Figure 4.2a Performance curves of conventional sensing techniques and IHSM under Weibull fading channel in non-cooperative scenarios.

The performance shown in Figure 4.2a is identical to that in Figure 4.1a. but in Weibull fading channel. It could be observed that while all technique has the same detection performance as compared to Figure 4.1a, their probability of detection has been deteriorated as a result of multipath fading experienced by the 5SUs. That is, it assumed that all the 5SUs used to sense the spectrum is suffering from multipath fading.

When $\frac{E_b}{N_o}$ equal to 0 dB, the probability of detection values of IHSM, MFD and CFD are 0.84, 0.48, and 0.28 respectively. From Equations (3.28a-c), the probability of detection of IHSM is increased by 36% and 56% as compared to MFD and CFD, respectively.

It is observed from the Figure 4.2a that the IHSM has the best performance as compared to the MFD and CFD methods, especially at a low value of $\frac{E_b}{N_o}$. MFD perform better than CFD method, since it has a good knowledge of the PU signal.

However, at $\frac{E_b}{N_o} = 2$ dB, their probability of detection became better and same in their detection performance. This is due to hasty generalization and conclusion of the 5SUs about the presence of PU.

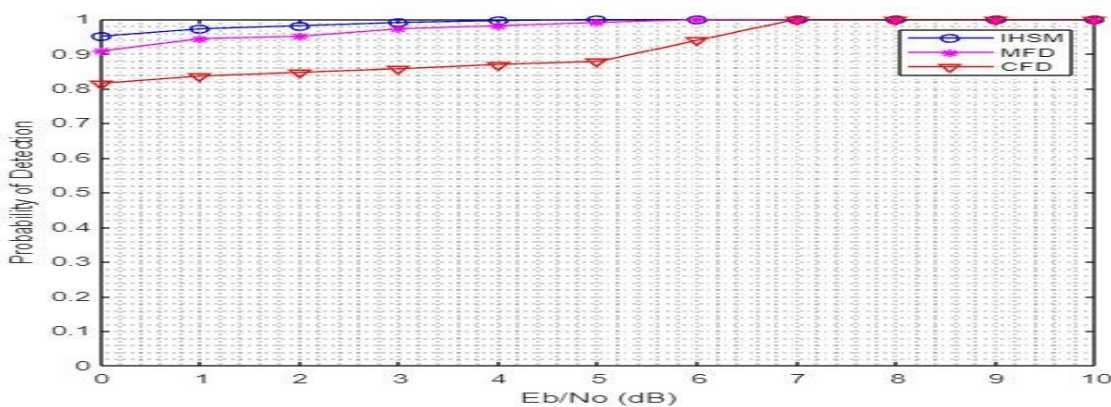

Figure 4.2b Performance curves of conventional sensing techniques and IHSM under Weibull fading channel in cooperative scenarios.

In the cooperative scenario, the effect of fading is minimized. Here, it assumed the 5SUs used to sense the spectrum and one of them is suffering from multipath fading.

At $\frac{E_b}{N_o}$ equal to 0 dB, the probability of detection values of IHSM, MFD and CFD are 0.96, 0.92, and 0.82 respectively. Hence, from Equations (3.28a-c), the probability of detection of IHSM is increased by 4% and 14% as compared to MFD and CFD, respectively.

It is observed that detection performance of the IHSM method is almost same to the MFD at low $\frac{E_b}{N_o}$ but the performance become the best as compared to the MFD and CFD techniques, especially at high value of $\frac{E_b}{N_o}$.

MFD perform better than CFD method, since it has a good knowledge of the PU signal. However, the performance of MFD becomes very bad when the knowledge of PU signal becomes poor and the CFD technique becomes the better technique in the detection performance. The performance curves, P_d increases as $\frac{E_b}{N_o}$ increases.

Table 4.2 show the summary of IHSM, MFD and CFD at $\frac{E_b}{N_o} = 0$ under Weibull multipath fading channel in non-cooperative and cooperative scenario.

Table 4.2 show the summary of IHSM, MFD and CFD at $\frac{E_b}{N_o} = 0$

CHANNEL TYPE	SCENARIO	PROBABILITY OF DETECTION AT $E_o/N_o = 0$		
		IHSM	MFD	CFD
WEIBULL	Non-Cooperative	0.84	0.48	0.28
		84%	48%	28%
WEIBULL	Cooperative	0.96	0.92	0.82
		96%	92%	82%

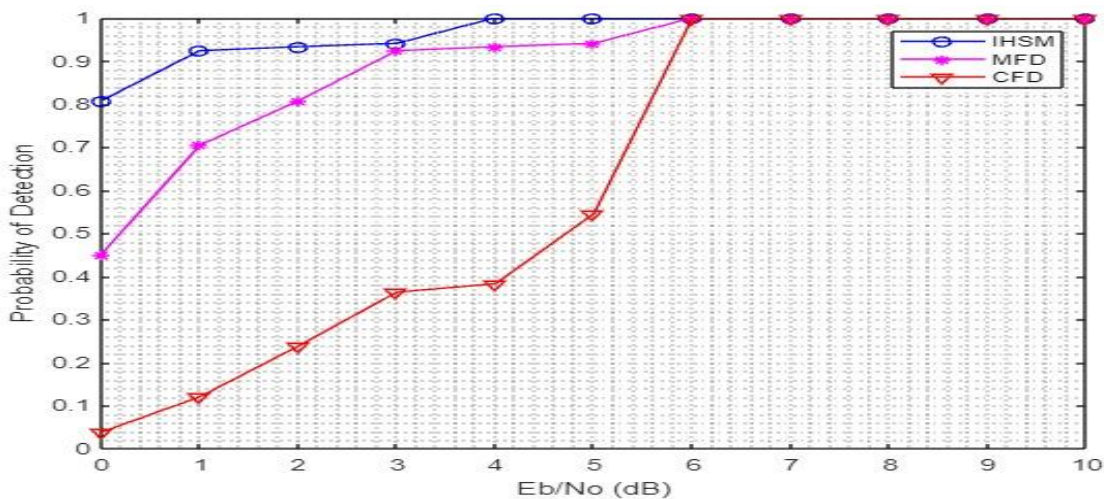

Figure 4.3a Performance curves of conventional sensing techniques and IHSM under Weibull fading channel plus AWGN in non-cooperative scenarios.

Here, the signal is transmitted through a Weibull fading channel while AWGN was added at the receiver with a deterioration due the case scenario by the 5SUs.

When $\frac{E_b}{N_o}$ equal to 0 dB, the probability of detection values of IHSM, MFD and CFD are 0.80, 0.44, and 0.4 respectively. From Equations (3.28a-c), the probability of detection of IHSM is increased by 36% and 76% as compared to MFD and CFD, respectively.

It is observed from the Figure that the proposed method (IHSM) has the best performance as compared to the MFD and CFD techniques, especially at a low value of $\frac{E_b}{N_o}$.

MFD perform better than CFD method, since it has a good knowledge of the PU signal.

However, the performance curves, P_d increases as $\frac{E_b}{N_o}$ increases and at $\frac{E_b}{N_o}$ equal to 6dB, the performance became same.

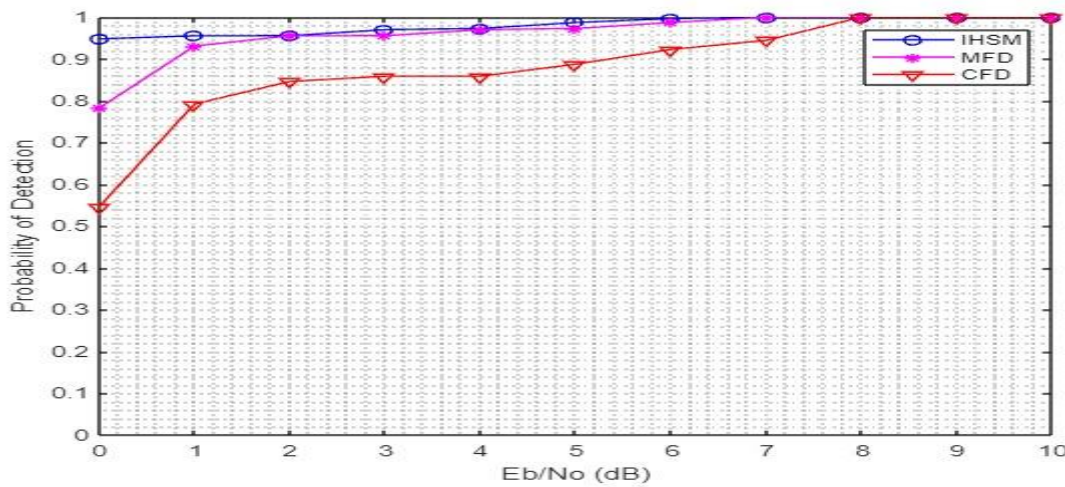

Figure 4.3b Performance curves of conventional sensing techniques and IHSM under Weibull fading channel plus AWGN in cooperative scenarios.

In this case, there is an improvement in the detection performance due to the cooperation of the 5SUs, the signal was transmitted through a Weibull fading channel while AWGN was added at the receiver.

When $\frac{E_b}{N_o}$ equal to 0 dB, the probability of detection values of IHSM, MFD and CFD are 0.96, 0.78 and 0.54 respectively. Hence, from Equations (3.28a-c), the probability of detection of IHSM is increased by 16% and 42% as compared to MFD and CFD, respectively. However, the performance of MFD becomes very bad when the knowledge of PU signal becomes poor and the CFD technique becomes the better technique in the detection performance. The performance curves, P_d increases as $\frac{E_b}{N_o}$ increases. This combination of fading and non-fading channel in spectrum sensing, present a more practical scenario of signals in the real-world systems.

Table 4.3 show the summary of IHSM, MFD and CFD at $\frac{E_b}{N_o} = 0$ under Weibull plus AWGN channel in non-cooperative and cooperative scenario.

Table 4.3 show the summary of IHSM, MFD and CFD at $\frac{E_b}{N_o} = 0$

CHANNEL TYPE	SCENARIO	PROBABILITY OF DETECTION AT $\frac{E_b}{N_o} = 0$		
		IHSM	MFD	CFD
WEIBULL + AWGN	Non-Cooperative	0.80	0.44	0.40
	In percentage	80%	44%	40%
WEIBULL + AWGN	Cooperative	0.96	0.78	0.54
	In percentage	96%	78%	54%

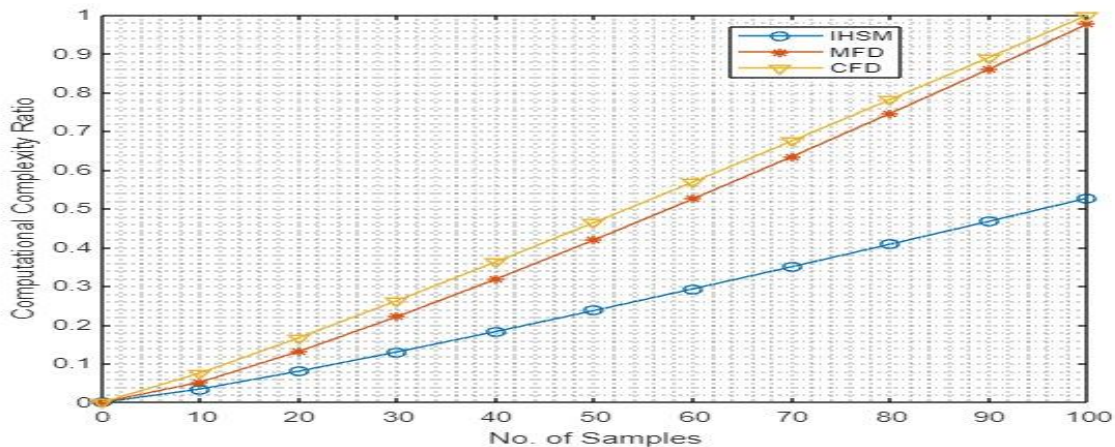

Figure 4.4 Computational complexity ratio versus the number of samples between conventional sensing techniques and IHSM.

At N equal to 50, the computational complexity ratio in IHSM, MFD and CFD are 0.24, 0.42 and 0.46 respectively. From Equations (29a-c), the computational complexity of IHSM is reduced by 18% and 22% as compared to MFD and CFD, respectively.

In addition, when N equal to 100, the computational complexity ratio in IHSM, MFD and CFD are 0.52, 0.98 and 0.99 respectively. Hence, the computational complexity of IHSM is reduced by 46% and 47% as compared to MFD and CFD, respectively. The computational complexity ratio curves increase as the number of samples, N increases. It can be seen that the IHSM has a lowest computational complexity compared to the MFD and CFD methods, since it computes the convolution process in the MFD stage or autocorrelation process in CFD with a quarter of the samples. Hence, these results demonstrated that the higher the number of samples, N the higher the computational complexity vice versa as shown in Table 4.4.

Table 4.4: Summary of computational complexity ratio.

S/N	NUMBER OF SAMPLE	COMPUTATIONAL COMPLEXITY RATIO, CC_{ratio}		
		IHSM	MFD	CFD
1	10	0.04	0.06	0.08
		4%	6%	8%
2	50	0.24	0.42	0.46
		24%	42%	46%
3	100	0.52	0.98	0.99
		52%	98%	99%

Table 4.4 compares the effectiveness of the proposed IHSM method with that of conventional methods (MFD and CFD) and hybrid method in [22]. This table demonstrates that the proposed method is the ideal option for spectrum sensing in terms of detection performance and computational complexity for very low $\frac{E_b}{N_0}$ and N values.

Table 4.1: Summary of performance measurement.

Method	Probability of Detection At $\frac{E_b}{N_0} = 0$ dB	Computational Complexity Ratio	
		At $N = 50$	At $N = 100$
Proposed method [IHSM]	Excellent (84%)	Low (24%)	Moderate (52%)
Hybrid method [22]	Very Good (58%)	Moderate (38%)	High (88%)
MFD	Good (when PU information is known, 48%)	High (42%)	High (98%)
CFD	Poor (28%)	High (46%)	High (99%)

5.0 CONCLUSION

The performance of the improved hybrid spectrum sensing method for cognitive radio networks, IHSM adopted for this research work in terms of detection performance and computational complexity in cooperative and non-cooperative scenarios under AWGN and Weibull fading channels achieved its objectives. The model was effective by reducing the latency of its detection performance and computational complexity.

This study introduces a novel technique for efficient sample selection, which significantly reduces the sensing time and computational complexity. By utilizing only, a fraction of the available samples ($N/4$ or 25%), the developed model outperforms existing methods such as MFD and CFD by 18% and 22% respectively. The IHSM method is more effective and efficient in the cooperative scenario than it is in the non-cooperative one because it greatly reduces the computational complexity. This improvement in efficiency not only enhances the overall performance of the sensing process but also offers practical advantages in terms of reduced computational requirements and faster detection of spectrum availability. The research work of the IHSM spectrum sensing technique also demonstrates a remarkable increase in detection accuracy compared to conventional methods. The developed IHSM model achieves a detection accuracy improvement of 48% and 68% when compared with MFD and CFD respectively. This substantial improvement in accuracy is of paramount importance in spectrum sensing applications, as it enables more identification that is reliable and utilization of available frequency bands, leading to improved spectrum utilization efficiency.

From the curves, it is clear that the probability of detection accuracy of the cooperating sensing is higher. It gives a more accurate picture of the spectrum holes or white spaces but takes a longer time to converge because it requires the contribution of the multiple nodes in the network.

However, the probability of detection of the non-cooperating sensing is not as high as cooperating; the non-cooperating scenario shows quicker convergence because it requires the judgement of only one node to take decision.

Therefore, from the analyses, it is evident that the IHSM scheme has an excellent in probability of detection and very good in the reduction of computational complexity.

Finally, by combining the efficient sample selection technique and the IHSM spectrum sensing method, this research work offers a comprehensive approach to improve the performance of spectrum sensing systems. The results not only validate the effectiveness of the proposed techniques but also contribute to advancing the field of cognitive radio and spectrum management.

This work can be further improved in the future using other types of fading channels e.g. log-normal, Hoyt (or Nakagami- q), Rayleigh, Rician (or Nakagami- n), and Nakagami- m . Its transmission stages i.e. the throughput for the cognitive users' performance should also be investigated, in order to improve the transmission of cognitive users. More so, by using double threshold in the sensing process can lead to an improvement in detection performance.

LIST OF SYMBOLS

$y(n)$	Received sensed signal by the SU
$x(n)$	PU signal
$h(n)$	Impulse response
μ	Known previous knowledge or information about PU
λ	Pre-defined threshold
Ra	Number of real additions
Rm	Number of real multiplications
N	Number of sensed samples
Fc	Carrier frequency
Fs	Sampling frequency
P_f	Probability of false alarm
P_d	Probability of detection
$R^{\alpha_{yy}}(l)$	Discrete cyclic autocorrelation function
Δn	Sampling interval
Pd_{MFDi}	Probability of detection of MFD stage
Pd_{CFDi}	Probability of detection of CFD stage

Pd_{IHSMi}	Probability of detection of IHSM
n	Number of SU
CC_{mfdFFT}	Computational complexity of traditional MFD
CC_{cfdFFT}	Computational complexity of traditional CFD
$CC_{ihsmPproposed}$	Computational complexity of the proposed IHSM method
CC_{ratio}	Ratio of computational complexity
E_b	Energy per Bit
N_o	Noise Spectral Density
E_b/N_o	Signal to noise ratio per bit
σ^2	SUs Variance
σ_n^2	Noise Variance
Ω	Instantaneous SNR
W	Bandwidth
W_N	Twiddle Factor
$x[n]$	Discrete Fourier Transform
$X[k]$	Inverse Discrete Fourier Transform

LIST OF ABBREVIATIONS

ANN	Artificial Neural Networks
AWGN	Additive White Gaussian Noise
BPSK	Binary Phase Shift Keying
CAF	Cyclic Autocorrelation Function
CC	Computational Complexity
CF	Cyclic Frequency
CFD	Cyclostationary Feature Detection
CU	Cognitive User
CR	Cognitive Radio
CRU	Cognitive Radio User
CS	Cyclic Spectrum
CSD	Cyclic Spectrum Density
CSS	Cooperative Spectrum Sensing
ED	Energy Detection
BPF	Band Pass Filter
DFT	Discrete Fourier Transform
FC	Fusion Centre
FPU_s	First Priority Users
GLRT	Generalized Likely Ratio Test
HD	Hybrid Detector
HSS	Hybrid Spectrum Sensing
IDFT	Inverse Discrete Fourier Transform
IHSM	Improved Hybrid Spectrum Sensing Method
MFD	Matched Filter Detection
MC&DE	Ministry of Communication and Digital Economy
MDAs	Ministry Department and Agencies
MME	Maximum–Minimum Eigenvalue
NBC	National Broadcasting Corporation
NCC	Nigerian Communication Commission
OFDM	Orthogonal Frequency Division Multiplexing
PTOs	Private Telecom Operators
PU	Primary User
Q	Marcum Q-function
QPSK	Quadrature Phase Shift Keying
RF	Radio Frequency
SDFT	Sliding Discrete Fourier Transform
SNR	Signal to Noise Ratio

SLC	Square Law Combination
SPUs	Second Priority Users
SS	Spectrum Sensing
SU	Secondary User
TSs	Test statistics
TVs	Televisions
XG Network	Next Generation Network
WRAN	Wireless Regional Area Network

REFERENCES

- [1] R.A.H. Suliman, K.H. Bilal and I. Elemam. *Review Paper on Cognitive Radio Networks*. Journal of Electrical & Electronic Systems, Volume 7 • Issue 1 • 1000252, 2018.
<https://doi.org/10.4172/2332-0796.1000252>
- [2] S. Pandit and G. Singh. *Spectrum Sharing in Cognitive Radio Networks*. Springer International Publishing AG, April 2017. DOI 10.1007/978-3-319-53147-2_2
- [3] M. E. Bayrakdar, A. Çalhan. Performance analysis of sensing based spectrum handoff process for channel bonding mechanism in wireless cognitive networks. In 2017 25th Signal Processing and Communications Applications Conference (SIU). Turkey, Antalya, 2017.
<https://doi.org/10.1109/SIU.2017.7960157>.
- [4] F. Shen, G. Ding, Z. Wang and Q. Wu, "UAV-Based 3D Spectrum Sensing in Spectrum-Heterogeneous Networks," in *IEEE Transactions on Vehicular Technology*, vol. 68, no. 6, pp. 5711-5722, June 2019.
- [5] *Federal Republic of Nigeria Official Gazette*. No. 22, Vol.108, Lagos – Nigeria. 5th February, 2021.
- [6] B.G. Najashi, F. Wenjiang and C. Kadri. *An Insight into Spectrum Occupancy in Nigeria*. International Journal of Computer Science Issues (IJCSI), Vol.10, Issue 1, No1, pp 1-6, 2013.
- [7] B. G. Najashi. *Spectrum Occupancy Measurements in Nigeria: Results and Analysis*. International Journal of Computer Science Issues (IJCSI), Vol.12, Issue 4, pp 1-10, July 2015
- [8] A. Brito, P. Sebastião, and F. J. Velez. Hybrid Matched Filter Detection Spectrum Sensing. *IEEE Access*, 2021
- [9] Ian F. Akyildiz, Won-Yeol Lee, Mehmet C. Vuran and Shantidev Mohanty. Next generation/dynamic spectrum access/cognitive radio wireless networks: A survey. Broadband and Wireless Networking Laboratory, School of Electrical and Computer Engineering, Georgia Institute of Technology, Atlanta, GA 30332, United States, Received 2 January 2006; accepted 2 May 2006. [Retrieved Sept. 2022]
- [10] Sk. Muntaj and D.A John. *A Review on Spectrum Sensing Techniques in Cognitive Radio Network*. International Journal of Modern Communication Technologies & Research (IJMCTR). ISSN: 2321-0850, Volume-4, Issue-7, July 2016.
<https://www.erpublication.org>
- [11] S. Althunibat. *Towards energy efficient cooperative spectrum sensing in cognitive radio networks*. Ph.D. thesis, University of Trento, Italy, 2014. <http://eprints-phd.biblio.unitn.it/1335/>.
- [12] Z. Ayoub, G. Khalil and A. Aziz. *Spectrum Sensing Using Cooperative Matched Filter Detector in Cognitive Radio* 23 June 2020. DOI: 10.20944/preprints20226.0319.v1
- [13] A.S. Khobragade and R.D. Raut. *Hybrid spectrum sensing method for cognitive radio*. International Journal of Electrical and Computer Engineering (IJECE) 7(5):2683–2695, 2017.
<https://doi.org/10.11591/ijece.v7i5.pp2683-2695>.
- [14] M. S. Falih and H. N. Abdullah. *DWT based energy detection spectrum sensing method for cognitive radio system*. Iraqi Journal of Information and Communications Technology 3(3):1–11, 2020.
<https://doi.org/10.31987/ijict.3.3.99>.

- [15] K. Yadav, S. D. Roy and S. Kundu. *Hybrid cooperative spectrum sensing with cyclostationary detection for cognitive radio networks*. In 2016 IEEE Annual India Conference (INDICON), pp. 1–6. 2016. <https://doi.org/10.1109/INDICON.2016.7839118>.
- [16] H.S Abed and H.N. Abdullah. *Improvement of Spectrum Sensing Performance in Cognitive Radio using Modified Hybrid Sensing Method*. Acta Polytechnica 62(2):228–237, 2022. <https://doi.org/10.14311/AP.2022.62.0228>
- [17] H. Arezumand and H. Sadeghi. *A low-complexity cyclostationary-based detection method for cooperative spectrum sensing in cognitive radio networks*. International journal of information and communication technology 3(3):1–10, 2011. <https://elmnet.ir/article/605357-22041>
- [18] Xue D, Ekici E and Vuran MC. *Cooperative Spectrum Sensing in Cognitive Radio Networks Using Multidimensional Correlations*. IEEE Trans Wirel. Commun. 2014;13(4):1832–43. <https://doi.org/10.1109/TWC.2014.022714.130351>.
- [19] P. Bachan, S. K. Ghosh and S. K. Saraswat. *Comparative error rate analysis of cooperative spectrum sensing in non-fading and fading environments*. In 2015 Communication, Control and Intelligent Systems (CCIS), pp. 124–127. 2015. <https://doi.org/10.1109/CCIntelS.2015.7437891>.
- [20] A. Mukherjee, P. Goswami and A. Datta. *HML-Based smart positioning of fusion center for cooperative communication in cognitive radio networks*. IEEE Communications Letters 20(11):2261–2263, 2016. <https://doi.org/10.1109/LCOMM.2016.2602266>.
- [21] S. K. Ghosh, S. R. Trankatwar and P. Bachan. *Optimal voting rule and minimization of total error rate in cooperative spectrum sensing for cognitive radio networks*. Journal of Telecommunications and Information Technology 1:43–50, 2021. <https://doi.org/10.26636/jtit.2021.144420>.
- [22] N Noorshams, M. Malboubi, and A. Bahai. *Centralized and decentralized cooperative spectrum sensing in cognitive radio networks: A novel approach*. IEEE 11th International Workshop on Signal Processing Advances in Wireless Communications. p. 1–5. 2010 <https://doi.org/10.1109/SPAWC.2010.5670998>.
- [23] H. N. Abdullah, Z. O. Dawood and A. E. Abdelkareem, H. S. Abed. *Complexity reduction of cyclostationary sensing technique using improved hybrid-sensing method*. Acta Polytechnica 60(4):279–287, 2020. <https://doi.org/10.14311/AP.2020.60.0279>.
- [24] H. N. Abdullah, N. S. Baker and M. T. S. Al-Kaltakchi. *Proposed two-stage detection rules for improving throughput in cognitive radio networks*. Iraqi journal of computers, communications, control & system engineering (IJCCCE) 19(4):1–11, 2019. <https://doi.org/10.33103/uot.ijccce.19.4.1>.
- [25] G. Goutam, D. Prasun and C. Subhagit . *Cognitive Radio and Dynamic Spectrum Access*. International Journal of Next-Generation Networks (IJNGN) Vol.6, No.1, March 2014
DOI : 10.5121/ijngn.2014.6104 43
- [26] N.K Hoven. *On the feasibility of cognitive radio*. MEE Rice University, 2003.
- [27] R.R. Jaglan, S. Sarowa, R. Mustafa, S. Agrawal and N. Kumar. *Comparative Study of Single-user Spectrum Sensing. Techniques in Cognitive Radio Networks*. Second International Symposium on Computer Vision and the Internet (VisionNet'15), 2015.
- [28] W. Adigwe and O. R. Okonkwo. *A review of cyclostationary feature detection based spectrum-sensing technique in cognitive radio networks*. E3 Journal of Scientific Research 4(3):041–047, 2016. [https://doi.org/10.18685/EJSR\(4\)3 EJSR-16-010](https://doi.org/10.18685/EJSR(4)3 EJSR-16-010).
- [29] I. G. Anyim. *Wideband Cyclostationary Spectrum Sensing with Receiver Constraints and Optimization*. Ph.D. thesis, University of Portsmouth, United Kingdom, 2018.

- [30] E.Rebeiz, P.Urriza and D.Cabric, "Optimizing Wideband Cyclostationary spectrum sensing under receiver impairments," IEEE Trans.On Signal Processing, Vol.61, No. 15, Aug. (2013).
- [31] W.O Ajadi, S.M Sani and A.M.S Tekanyi. Estimation of an Improved Spectrum Sensing Threshold for Cognitive Radio using Smoothed Pseudo Wigner – Ville Distribution Signal. Vol., 3 pp. 9, 2017.
- [32] S Nallagonda, S. K Bandari, S. D Roy and S. Kundu. On Performance of Weighted Fusion Based Spectrum Sensing in Fading Channels. Journal of Computational Engineering. Dec 2013. <https://doi.org/10.1155/2013/270612>
- [33] N. Narayan, S. Sudeep and K. Nirajan. Energy detection based techniques for Spectrum sensing in Cognitive Radio over different fading Channels. Cyber Journals: Multidisciplinary Journals in Science and Technology, Journal of Selected Areas in Telecommunications (JSAT), February Edition, 2014
- [34] S. B. Shawkat, Md. M-Ul-Haque, Md. S. Islam and B. S. Sonok. Fundamental Capacity Analysis for Identically Independently Distributed Nakagami-q Fading Wireless Communication. International Journal of Advanced Computer Science and Applications, (IJACSA) Vol. 11, No. 9, 2020
- [35] D. H. Pavlovic, N. M. Sekulovic, G. V. Milovanovic, A. S. Panajotovic, M. H. Stefanovic and Z. J. Popovic. Statistics for Ratios of Rayleigh, Rician, Nakagami-m, and Weibull Distributed Random Variables. Mathematical Problems in Engineering, 2013.
- [36] C. Sagias and George K. Karagiannidis. Gaussian Class Multivariate Weibull Distributions: Theory and Applications in Fading Channels Nikos. IEEE Transactions on Information Theory, Vol. 51, No. 10, October 2005
- [37] M. D. Jacoub. The α - μ distribution: A general fading distribution, in Proc. IEEE Int. Symp. Personal, Indoor, Mobile Radio Communications, Lisbon, Portugal, Sep. 2002.
- [38] M. Ranjeeth1, S. Nallagonda and S.Anuradha. Optimization Analysis of Improved Energy Detection based Cooperative Spectrum Sensing Network in Nakagami-m and Weibull Fading Channels. Journal of Engineering Science and Technology Review, 2017.
- [39] A.A Kumar. Digital Signal Processing K.L.U. College of Engineering, K.L. University Vijayawada, Andhra Pradesh PHI Learning Private Limited New Delhi, 2013
- [40] A. Nasser, M. Chaitou, A. Mansour, K-C Yao and H. Charara. *A Deep Neural Network Model for Hybrid Spectrum Sensing in Cognitive Radio*. Wireless Personal Communications, Springer Verlag, 2021. <https://doi.org/10.1007/s11277-020-08013-7>.
- [41] A. R. Mohamed, A. A. A. El-Banna and H. A. Mansour. Multi-path hybrid spectrum sensing in cognitive radio. Arabian Journal for Science and Engineering 46:9377-9384, 2021. <https://doi.org/10.1007/s13369-020-05281-0>.
- [42] D. Joshi, N. Sharma and J. Singh. *Spectrum Sensing for Cognitive Radio Using Hybrid Matched Filter Single Cycle Cyclostationary Feature Detector*. I.J. Information Engineering and Electronic Business 5, 13-19. September 2015. DOI: 10.5815/ijieeb.2015.05.03
- [43] R. Kaur and S. Sharma. *Analysis of Hybrid Model based on Energy and Cyclostationary Spectrum Sensing Techniques*. International Journal of Scientific & Engineering Research, Volume 8, Issue 2, February-2017.
- [44] K. Arshid, Z. Jianbiao, I. Hussain, M.S. Pathan, M. Yaqub, A. Jawad, R. Munir and F. Ahmad. *Energy efficiency in cognitive radio network using cooperative spectrum sensing based on hybrid spectrum handoff*. Egyptian Informatics Journal. 22 June, 2022 <https://doi.org/10.1016/j.eij.2022.06.008>
- [45] B. Ahuja and G. Kaur. A Novel Design of Improved Hybrid Spectrum Sensing Technique for Cognitive Radio. International Journal of Computer Applications (0975 – 8887) Volume 125 – No.13, September 2015.
- [46] R. Rajaguru1, K.V. Devi and P. Marichamy. *A Hybrid Spectrum Sensing Approach to Select Suitable Spectrum Band for Cognitive Users*. Computer Networks (2020) <https://doi.org/10.1016/j.comnet.2020.107387>

- [47] K. Bani and V. Kulkarni. *Hybrid Spectrum Sensing Using MD and ED for Cognitive Radio Networks*. Journal of Sensor and Actuator Network 11, 36. Pg 1-15, 2022. <https://doi.org/10.3390/jsan11030036>
- [49] Wireless Applications Corp. 16689 SE 59 t h Street Bellevue, WA 98006. Retrieved 23rd October 2022. <https://ftp.unpad.ac.id/orari/library>
- [48] R. Jain. *Channel Models: A Tutorial*. Vol1.0 February 21, 2007. Cited from ITU-R Recommendation M.1225, "Guidelines for evaluation of radio transmission technologies for IMT-2000," 1997.
- [50] S. U. B. Atapattu. Analysis of Energy Detection in Cognitive Radio Networks. Ph.D. thesis, University of Alberta, Edmonton Alberta, 2013. http://www.ece.ualberta.ca/~chintha/pdf/thesis/phd_saman.pdf