

FAULT DETECTION IN FIVE BUS SYSTEM USING MATLAB & SIMULINK (DISCRETE WAVELET TRANSFORM METHOD)

Suraj Kumar Padhan¹, Lokesh Jaiswal², Pranjal Prajapati³ and Ganesh Ram Ratnakar⁴

¹ Department of Electrical and Electronics Engineering, Chouksey Engineering College, Bilaspur, Chhattisgarh, India

² Department of Electrical and Electronics Engineering, Chouksey Engineering College, Bilaspur, Chhattisgarh,, India

³ Department of Electrical and Electronics Engineering, Chouksey Engineering College, Bilaspur, Chhattisgarh,, India

⁴ Assistant Professor, Department of Electrical and Electronics Engineering, Chouksey Engineering College, Bilaspur, Chhattisgarh,, India

Abstract - The transmission line is a critical component of the power system, but it is vulnerable to faults due to its exposure to harsh environmental conditions. These faults, such as open circuit and short circuit, directly affect the quality of the electric power supplied. Therefore, it is essential to promptly detect and fix any faults to ensure the reliable operation of the power system. Fault diagnostics are crucial for maintaining the stability of a multi-bus system within the power system. This research focuses on a five-bus system and presents twelve different types of faults with varying durations in transmission lines at different locations. To determine the specific fault type, the receiving end current signals of the line undergo Discrete Wavelet Transform (DWT). The resulting wavelet coefficients are then used in the fault identification process. The simulation and extraction of wavelet coefficients are carried out accordingly.

through a transmission line network comprising seven lines [8]. Detailed specifications for the transmission lines, sources, and loads can be found in Tables 1 and 2.

It is worth noting that Bus number 2 is connected to both a generator and a load. Additionally, Bus 1, referred to as the Generator Bus, serves as the Slack Bus, responsible for maintaining a balance between active and reactive power. For the purpose of this study, a Typical 5 Bus configuration has been adopted as the base system for analysis. Table 1 presents the Transmission Line specifications for a T-section Model. A fitting reference value of 100 MVA, denoted as S_b , and a base kV of 230 kV, denoted as V_b , are utilized. The specifications include the values for Positive and Zero Sequence Resistance, as well as Inductance.

Keywords: Line fault, Discrete Wavelet Transforms (DWT), Wavelet coefficient, five bus system, MATLAB.

1. Introduction

Ensuring that energy is clean, affordable, and reliable is crucial in the fight against poverty and climate change. With the increasing integration of renewable energy by various agencies, Grid Automation is becoming an inevitable task in smart grids. Transmission line faults, whether symmetrical or unsymmetrical, occur frequently due to various adverse factors such as environmental imbalances, overloads, and lack of maintenance [1]. Detecting these faults in a timely manner is essential for maintaining a reliable power system with minimal interruptions. In recent years, several decision algorithms have been proposed for locating faults in multi-terminal systems [2–4]. This paper focuses on using wavelet transform [5–7], specifically the db8 wavelet, to extract fault features from line currents in transmission lines. By analyzing these features, the type of fault can be identified [9].

2. System Under Study

The provided Figure 1 illustrates the single Line Diagram of a five bus system that is being analyzed. This system consists of two sources and four loads, all interconnected

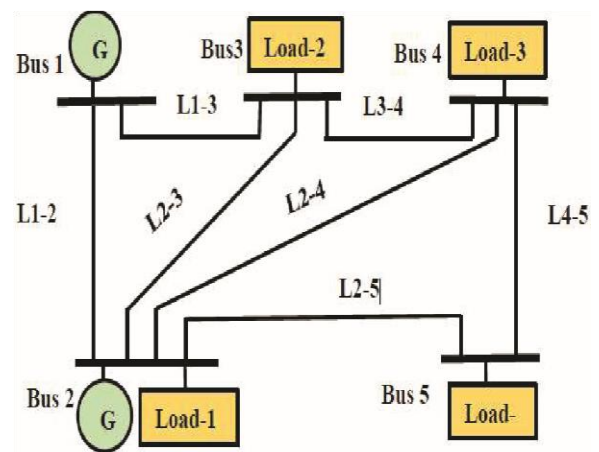

Figure 1:- Five bus system under study.

Table 1 :- Transmission line specifications

Bus	Length of Trans. Line km	Positive Seq. R (Ω /km)	Zero Seq. R (Ω /km)	Positive Seq. L (H/km)	Zero Seq. L (H/km)	Positive Seq. C (F/km)	Zero Seq. C (F/km)
1-2	46	0.23	0.66	0.0017	0.0052	6.3×10^{-9}	1.89×10^{-8}

1-3	86	0.47	1.45	0.0038	0.0115	2.87×10^{-9}	8.62×10^{-9}
2-3	68	0.46	1.40	0.0037	0.0112	2.97×10^{-9}	8.91×10^{-9}
2-4	68	0.46	1.40	0.0037	0.0112	2.97×10^{-9}	8.91×10^{-9}
2-5	46	0.45	1.34	0.0035	0.0105	3.15×10^{-9}	9.45×10^{-9}
3-4	18	0.27	0.813	0.0021	0.0064	5.14×10^{-9}	1.54×10^{-9}
4-5	86	0.47	1.455	0.0038	0.0115	2.87×10^{-9}	8.62×10^{-9}

Table 2 Source and load specifications

Bus	P_G (W)	Q_G (VAR)	Q-Max (VAR)	Q-Min (VAR)	P_L (W)	Q_L (VAR)
1	0	0	500×10^6	500×10^6	0	0
2	40×10^6	0	300×10^6	-300×10^6	20×10^6	10×10^6
3	0	0	0	0	45×10^6	15×10^6
4	0	0	0	0	40×10^6	5×10^6
5	0	0	0	0	60×10^6	10×10^6

The Transmission Line model incorporates the calculation and application of capacitance. The length of the Transmission Line is determined by considering the resistance and reactance values [8]. In MATLAB/Simulink, the Load Flow Bus Block should be connected to the Bus where the voltage and angle measurements are required. Table 2 provides information on the Load Flow requirements for the Source and Load Bus. The Real and Reactive Power values for all five Buses are obtained from the Generator and Load Block, as indicated in Table 2.

3. Simulation Of Five Bus System

The MATLAB/Simulink environment was utilized to develop the Five Bus model of the power system, with the specified parameters. A load flow study was conducted under normal operating conditions. The Load Flow Studies Block in MATLAB/Simulink was employed to obtain the Load Flow results after performing the simulation. These results are presented in Table 3, which demonstrates that the system is functioning flawlessly under steady state conditions.

Additionally, Figure 2 illustrates a pie section model of the 5 bus system that was used for the simulation. The continuous block was employed for simulation in discrete time. A 100 kVA system consisting of Five Buses was considered for the simulation, with the system specifications provided in Tables 2 and 3.

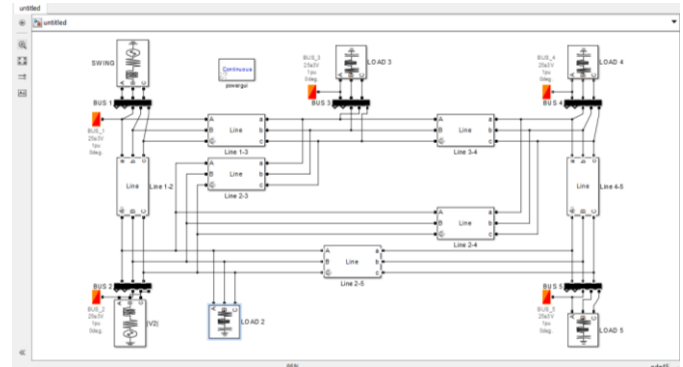
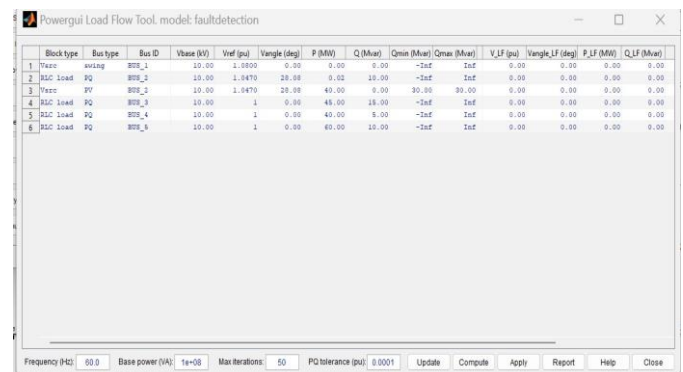

Figure 2 :- Simulated five buses system.

Table 3 :- Load flow results of five bus system



Block type	Bus type	Bus ID	Vbase (kV)	Vref (pu)	Vangle (deg)	P (MW)	Q (Mvar)	Qmin (Mvar)	Qmax (Mvar)	V_LF (pu)	Vangle_LF (deg)	P_LF (MW)	Q_LF (Mvar)
1	Wdg	BUS_1	10.00	1.0000	0.00	0.00	0.00	-Inf	Inf	0.00	0.00	0.00	0.00
2	RLC Load	BUS_2	10.00	1.0470	28.08	0.00	30.00	-Inf	Inf	0.00	0.00	0.00	0.00
3	Wdg	BUS_3	10.00	1.0470	28.08	40.00	0.00	30.00	30.00	0.00	0.00	0.00	0.00
4	RLC Load	BUS_4	10.00	1	0.00	40.00	18.00	-Inf	Inf	0.00	0.00	0.00	0.00
5	RLC Load	BUS_5	10.00	1	0.00	40.00	5.00	-Inf	Inf	0.00	0.00	0.00	0.00
6	RLC Load	BUS_5	10.00	1	0.00	60.00	10.00	-Inf	Inf	0.00	0.00	0.00	0.00

The MATLAB software is utilized to design and simulate the system. By employing the 3-phase Fault Generator Block, a three phase Fault is introduced to the system, and the resulting signals are captured at the receiving end for all twelve Fault conditions. The Simulation time that is taken into account is 0.1 s.

4. Interpretation From The Simulation Results

The analysis for detecting three-phase faults is currently being conducted using the MATLAB/Simulink Tool. In order to effectively capture the features of fault signals, the Wavelet Transform Db8 Level 6 has been chosen for Fault Detection. If the fault involves the ground, the sum of detailed coefficients in the three phases will not be equal to zero. However, if there is no fault, the sum will be equal to zero. Under faulty conditions, the sum of detailed coefficients in the three phases is found to be different from that of healthy conditions. Even though the wavelet coefficients do not deviate significantly when the fault duration is reduced, they are still sufficient to distinguish between healthy and

faulty conditions. The use of Db8 at level 6 yields good results in identifying faults regardless of their location, duration, or varying load conditions.

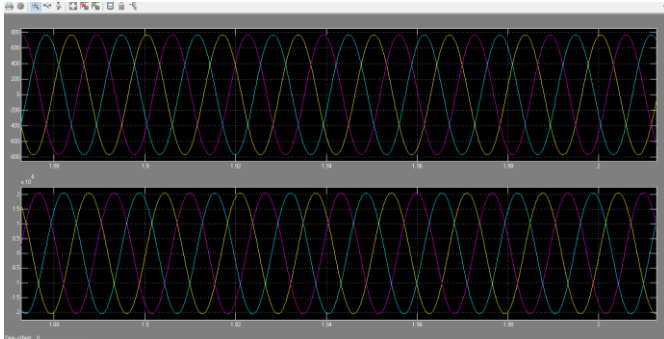

Figure 3:- Receiving end voltage and current in line connected between buses 2 and 5 under healthy condition.

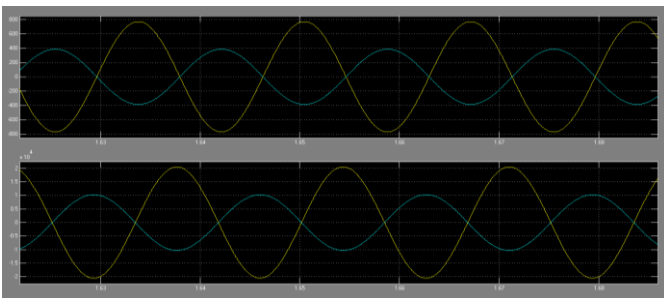

Figure 4:- Receiving end voltage and current in line connected between buses 2 and 5 under faulty condition.

5. Conclusion

The research paper focuses on utilizing a DWT based approach to detect and classify faults in transmission lines within a five-bus system. By employing the Discrete Wavelet Transform (DWT) method, faults can be accurately located. The method involves analyzing the transient change in the power system's current using the Daubechies 8 wavelet transform. The detailed coefficients extracted from this analysis are then utilized to identify faults in different phases, considering varying load conditions and fault locations. The obtained results demonstrate that the db8 mother wavelet yields a mean error of -0.34% . Given the satisfactory accuracy of the proposed method for different fault types, it can be further expanded to larger bus systems. Consequently, a Fault detection and classification algorithm can be developed based on the discrete wavelet transform, which has proven to be successful in handling varying fault locations, durations, and load conditions

6. References

1) Badri Ram and D.N. Vishwakarma, "Power System Protection and Switchgear", Tata McGraw Hill Publication Company Limited, New Delhi, 2005.

- 2) D. Chanda, N.K. Kishore and A.K. Sinha, "Application of wavelet multiresolution analysis for identification and classification of faults on transmission lines", *Electric Power Systems Research*, Vol. 73, pp. 323-333, 2005.
- 3) Mazen Abdel-Salam, Adel Ahmed and WaelAhmed, "Wavelet Based Analysis for Transmission Line Fault Location", *Innovative Systems Design and Engineering*, Vol. 4, No. 14, 2013.
- 4) P. Chiradeja and C. Pothisarn, "Identification of the Fault Location for Three-Terminal Transmission Lines using Discrete Wavelet Transforms", *T&D Asia* 2009.
- 5) H. Fernando, Magnago and Ali Abur, "Fault Location Using Wavelets", *Transactions on Power Delivery*, pp. 1475-1480, October 1998.
- 6) Daubechies, "The wavelet transform, time-frequency localization and signal analysis", *Transactions of Information Theory*, pp. 961- 1005, September 1990.
- 7) C.H. Kim and R. Aggarwal, "Wavelet transforms in power systems: Part 1. General introduction to the wavelet transforms", *Power Engineering Journal*, pp. 81-87, April 2000.
- 8) Anjali Atul Bhandakkar and Dr. Lini Mathew, "Real-Time-Simulation of -5-Bus Network on OPALRT-OP4510 Simulator", 3rd International Conference on Communication Systems (ICCS), 2017.
- 9) Maliye Sri Pranav, Kanipakam Vishal, Chigurupati Karthik, Jakkamsetti Tarun and Dr. D. Kavitha, Dr. V. Vanitha, "Fault Detection and Classification in Three Phase Transmission lines using Signal Processing", Third International conference on Recent Trends in Electronics and Communication Technology, 2018.