

# VEHICLES PARKING BY USING HYDRAULIC SYSTEM

Prashant S. Kottalagi<sup>1</sup>, Mahesh P. Patil<sup>2</sup>, Saloni I. Jamadar<sup>3</sup>

<sup>123</sup>Student, Department of Mechanical Engineering, Kolhapur Institute of Technology's College of Engineering Kolhapur.

\*\*\*

**Abstract** - The aim of this project is to produce hydraulic system for parking the vehicles. Generally, in public malls multi level parking is present, for travel the vehicle from first floor to second floor is carried out with the help of ramp. The construction of ramp requires cost and huge space. To overcome this disadvantage we have designed hydraulic system. By using this hydraulic parking system we can transfer the vehicle from first floor to second floor without using ramp. We proposed simple hydraulic circuit by using Automation Studio software.

**Key Words:** pump, oil reservoir, direction control valve, counter balance valve, actuator, hoses etc.

## 1. INTRODUCTION

The major problem in any of the parking system are traffic jams and lack of parking spaces, this problem is solved by automatic car parking using hydraulic system. This hydraulic car parking system plays a crucial role to utilize the space which is occupied by ramps in multilevel car parking system.

The multilevel car parking has to deal with the traffic congestion which leads to loss of time, the hydraulic car parking system prevents the traffic congestion as the parking is automated and also prevents change caused during manual parking in multilevel car parking. The hydraulic car parking is durable and secure which consist of piston cylinder arrangement, counterbalance valve, directional control valve, pressure relief valve, pump, motor, filter and reservoir.



Fig 1:- Current parking system

During parking operation car is raised and lowered smoothly within certain time which benefits the user as this avoids extra time required to take out the car from first floor to ground floor through ramps in manual case. The hydraulic car parking can be operated by one or two operators which reduce the labour cost also the hydraulic parking system helps in ticketing with less time and less manpower which results in low cost of management and faster processing.

## 2. LITRETURE REVIEW

The research done hydraulic car parking by Whor says that, there are different parking systems, like multilevel car parking system utilizes an electric motor or hydraulic power to lift and transport comes from the entry level to vacant spaces on upper levels.

The research done by Rahul Kolekar, S.S. Gawade says that metropolitan cities strongly need an advanced parking system, so they have developed a lift for parking which is operated by hydraulic system. This will provide considerable negotiable parking prices and selects the optimal car park for driver.

According to research Shannon Saunders on hydraulic parking system to gave the opacity which occupied by the hydraulic pour spark and actuators system which will help utilize the tight spaces accused by minima parking.

## 3. CONSTRUCTION

The hydraulic parking system consists of a hydraulic Actuator which has a piston, connecting rod and double acting cylinder the counterbalance valve which is connected at lower end of cylinder. The Directional control valve is used for changing the direction of fluid flow into the actuator, we have used pressure relief valve for safety purpose with Pressure gauge for pressure measurement.

The electric motor is connected to the hydraulic pump to provide motion and in line filter is connected to remove the Dust and solid particles from fluid. For Storing fluid the reservoir is installed which stores the hydraulic fluid. The car is kept on a square plate which is operated by hydraulic Actuator.

#### 4. FUNCTIONS OF COMPONENT

##### 1) Reservoir:-

To store sufficient amount of hydraulic oil required for the system and cool the hot return oil.

##### 2) Filter :-

To remove the dirt and particles present in the oil.

##### 3) Pump:-

The function of rotary pump is to pump hydraulic oil to the hydraulic circuit by increasing the pressure of oil.

##### 4) Pressure control valve:-

This valve is heart of the every hydraulic system. It is used for control pressure inside the system for safety purpose. This valve is connected at the outlet of pump.

##### 5) Pressure gauge :-

To indicate the pressure generated inside the system. Pressures setting are made by looking to pressure gauge.

##### 6) Direction control valve:-

To control the forward and reverse motion of actuator by changing the lever direction or push button position.

##### 7) Counter-balance valve:-

Counterbalance valves are used in hydraulic systems working with an overriding (run-away) or suspended load. They are designed to create backpressure at the return line of the actuator to prevent losing control over the load.

##### 8) Actuator:-

The actuator in hydraulic control system is to convert the hydraulic energy produced by the pump into useful work.

##### 9) Hoses:-

Hoses are used to carry fluids through air or fluid environments, they are typically used with clamps, spigots and nozzles to control the fluid flow.

#### 5. WORKING

The hydraulic system works on the principle of Pascal law. Statement: According to Pascal law, "the external static pressure applied on the confined liquid is distributed or transmitted evenly throughout the liquid in all direction".

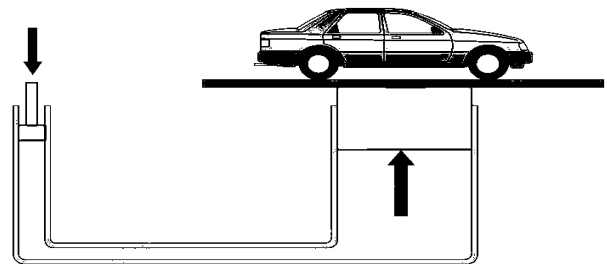

Fig 2:- Pascal's law

The purposed design is made for raising and lowering the car. Here we have used hydraulic power pack and DCV for the operation we have provided the reservoir which contains sufficient amounts of hydraulic fluid.

The hydraulic pack consists of a pressure relief valve and a hydraulic pump, electric motor, filter and reservoir. When lifting the car, hydraulic pump transfer or supply the oil to by direction control valve, which then transferred to the Actuator. The Actuator consists of piston and cylinder. Due to the force of fluid the piston moves and therefore the car lifted smoothly, we have provided a counterbalance valve so that during lowering the car, the movement will be smooth; otherwise the car will come down at high speed which will damage the entire system. We have also provided pressure relief valve, so when the system pressure goes beyond the limit, the pressure relief valve will release the pressurized fluid back to the reservoir until the pressure reaches to normal. The motion of raising and lowering of the car is within short time which saves the time.

## 6. PROPOSED HYDRAULIC CIRCUIT

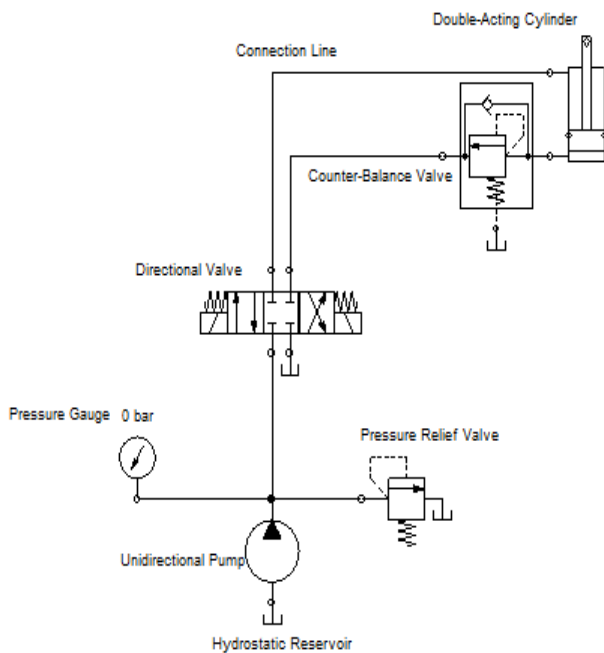

Fig 3:- Hydraulic system circuit

## 7. DESIGN OF COMPONENTS

The prime components used in the system are hydraulic actuator, directional control valve, counterbalance valve, pressure relief valve, motor, pump, pressure gauge, hose and reservoir. The following are the formulas for getting the dimension for the constrained condition of design.

### 1) For hydraulic actuator :

From manufacturer's catalogue rod and bore diameter are to be selected.

$$P = F/A$$

Where,

P= pressure

F= force

A= area

For flow rate:

$$Q = A \times V$$

Where,

Q=discharge

V=velocity

### 2) For pump:

Pump is selected from manufacturer's catalogue based on flow rate and pressure of oil.

### 3) For pressure relief valve (PRV) and direction control valve (DCV):

PRV and DCV are selected from manufacturer's catalogue based on working pressure.

### 4) For selection of tubing :

Inner and outer diameter of tubing is selected from manufacturer's catalogue based on velocity and flow rate of oil.

### 5) For counterbalance valve :

Counterbalance valve is selected from manufacture's catalogue based on maximum pressure in the system.

### 6) Reservoir capacity:

Reservoir capacity = 3 or 4 × Q

### 7) Selection of motor :

Motor is selected as per the requirement of speed for the hydraulic system.

## 8. CONCLUSIONS

For parking the vehicles in multilevel parking system requires ramp, due to this construction cost of ramp is high and also ramp occupies more space of floor. We know that costs of lands in cities are very high. So, by using hydraulic system for parking the car, we can eliminate the ramp. The cost required for the hydraulic system is less as compare to cost of construction of ramp; hence we can reduce the cost and can utilize the space occupied by ramp.

## 9. REFERENCES

- E. John Finnemore, Joseph Franzini "Fluid Mechanics with Engineering Applications", McGraw-Hill, 2002.
- Cassidy, John I., Chaudhry, M. Hanif, and Roberson, John A. "Hydraulic Engineering", John Wiley & Sons, 1998.
- Kirby, B.J. (2010). Micro- and Nanoscale Fluid Mechanics: Transport in Microfluidic Devices: Chapter 3: Hydraulic Circuit Analysis. Cambridge University Press. ISBN 978-0-521-11903-0. Archived from the original on 2020-11-24. Retrieved 2020-01-04.
- Oil Hydraulic system by S.R. Mujumdar.