

# Optimization of Organic Rankine Cycle's thermal efficiency based on Grey relational analysis with Taguchi method

Jayesh Choudhary<sup>1</sup>, Purushottam Sahu<sup>2</sup>, Ghanshyam Dhanera<sup>3</sup>

<sup>1</sup> Research Scholar, BM College of Technology, Indore

<sup>2</sup> Professor and HEAD, BM College of Technology, Indore

<sup>3</sup> Assistant Professor, BM College of Technology, Indore, MP

\*\*\*

**Abstract** - For the statistical analysis in this study, the following 9 basic process parameters were chosen: working fluid type, heat exchanger efficiency, pinch point temperature differential in the evaporator and condenser, superheating temperature, evaporation temperature, and condensation temperature. The methodology employed was based on the Organic Rankine Cycle (ORC), where 9 tests were conducted using Taguchi's normal 19 orthogonal array. Subsequently, multi-response optimization was performed using principal component and grey relational analyses.

A comprehensive statistical analysis was conducted to assess the impact of these parameters on the efficiencies of the ORC system. To validate the results, confirmation tests were carried out, demonstrating good agreement between the predicted and experimental values of the response variables at the optimum combination of input parameters.

The optimum operating conditions for the ORC system were identified as A1B1C3D3E3F3G1H3I3, while the worst operating conditions were A3B3C1D1E1F1G3H1I1, both within the range of the analyzed operating conditions. The first law efficiencies of the system were determined to be 17.3% for the best case and 9.6% for the worst case.

This study provides a ranking of the ORC process parameters based on their statistical impact weight, highlighting which parameters are effective and ineffective in relation to the system's efficiencies.

Regenerate response

**Key Words:** Grey relation analysis, Organic Rankine Cycle; Thermal Efficiency; Taguchi

Method; ANOVA

## 1. INTRODUCTION

The Organic Rankine Cycle (ORC) is a thermodynamic process that converts low-temperature heat sources into electricity by using an organic working fluid. An ORC system's thermal efficiency is influenced by a number of factors. The Taguchi method and grey relational analysis

can be used to examine the impact of various factors on the ORC system's thermal efficiency.

Grey relational analysis is a technique for examining the connection between several variables and their effects on a specific result. The Taguchi technique, on the other hand, is a statistical strategy that enhances a system's performance by pinpointing the important variables that cause variability.

To analyse the relevant factors affecting the ORC's thermal efficiency using the Taguchi method and Grey relational analysis, you would typically.

The Taguchi method is a statistical approach that allows for the evaluation of the significance of different factors in relation to the objective function. This method can be applied in experiments, theoretical analysis, and numerical simulations to examine the effects of various parameters on the exergy and thermal efficiency of the Organic Rankine Cycle (ORC).

Considering the growing urgency of climate-related issues, there is a need for further research on the ORC system's environmental performance, its role in emission reduction, and its integration within low-carbon energy scenarios. When designing optimization objectives, it is recommended that researchers consider thermodynamic, economic, and environmental performance in conjunction. Additionally, working fluids can also be evaluated based on safety indicators, besides other criteria.

In recent years, the development of Organic Rankine Cycles (ORCs) has played a significant role in the expansion of commercial geothermal power utilization. This technology, particularly in the context of low-temperature geothermal energy, has opened new possibilities for its application.

To determine the optimal working fluid pairs for ORC systems, a multi-objective optimization approach was employed, considering 26 working fluid options. For simple ORC systems, a multi-objective optimization was conducted using exergy efficiency and levelized energy cost as the objective functions, with the aim of obtaining the most favorable results.

The increasing importance of energy utilization and environmental regulations has led to a greater emphasis on the analysis of thermodynamic cycles. Accurate and advanced thermodynamic analysis is essential for efficient energy utilization in thermal systems. The first and second laws of thermodynamics provide valuable insights into the behavior of thermodynamic systems, detailing the movement of heat and work. The first law expresses the conservation of energy, while the second law determines the direction of this conservation. The combined analysis of the first and second laws of thermodynamics is the most effective approach for evaluating the performance of thermal systems. Figure 4.1 illustrates the components of a basic Organic Rankine Cycle (ORC) used to convert waste heat into useful electrical power. The basic ORC consists of four distinct processes: Method 1-2 (pumping), Method 2-3 (constant-pressure heat addition), Process 3-4 (expansion), and Process 4-1 (constant-pressure heat rejection).

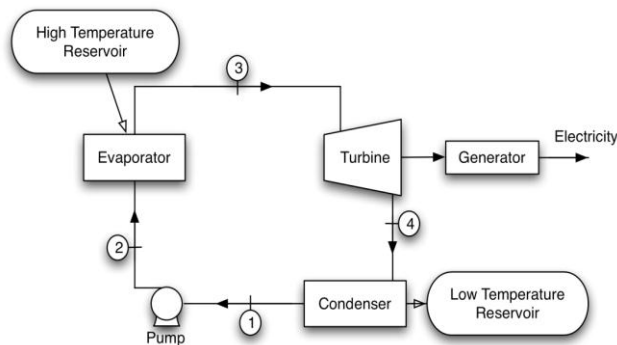

The first and second laws of thermodynamics are applied to each individual component to determine work output, heat added or rejected, and component and system irreversibility. The energy balance equation is as follows:

$$\sum_i E_i + \dot{Q} = \sum_o E_o + \dot{W}$$

Where  $E_i$  and  $E_o$  are the energy rate in and out,  $Q$  is the heat transfer rate, and  $W$  is the

Power. (Somayaji 2008)

a. Process 1-2 (Pump): The liquid is transferred from the condenser to the evaporator at Point 1 through a pump. The power required by the pump can be determined using Equation (4.1), assuming adiabatic pump efficiency.

b. Process 2-3 (Evaporator): In this stage, the working fluid passes through the evaporator, where it absorbs heat and undergoes vaporization as it moves from the pump outlet to the turbine inlet. The rate of heat transfer from the energy source to the working fluid can be calculated using a control volume that encompasses the evaporator.

c. Process 3-4 (Turbine): Vaporized fluid from Point 3 expands through the turbine to generate mechanical energy before being directed to the condenser at Point 4. The power output of the turbine can be determined based on a constant volume surrounding the turbine and the turbine's isentropic efficiency. The equation for turbine power includes the particular entropies of the working fluid at the condenser's inlet ( $s_1$ ) and exit ( $s_4$ ), as well as the temperature of the low temperature reservoir (TL). In this case, TL is considered equal to LL  $T = T_1 - \Delta TL$ .

## 2. LITERATURE REVIEW

This study offers valuable insights into the effective and ineffective process parameters in the Organic Rankine Cycle (ORC), accompanied by a statistical ranking of their impact weights. The working conditions have been optimized to maximize both the first and second law efficiencies. Therefore, this optimization study serves as a valuable resource for researchers, enabling them to design more efficient ORC systems while considering various factors such as thermodynamics, economics, environment, and safety indicators (Bademlioglu, Canbolat, and Kaynakli, 2020).

The literature review conducted in this study focuses on identifying papers that primarily emphasize the ORC. The majority of the papers analyzed were published after 2015, indicating a growing interest in multi-objective optimization (MOO) in system design. The work is organized into six chapters, covering optimal control goals based on thermodynamic, economic, environmental, and safety indicators. The advantages and disadvantages of various optimization techniques are also discussed in the third section.

The study's main contributions are twofold: firstly, it provides a comprehensive summary of the major advancements in ongoing multi-objective research, and secondly, it offers detailed recommendations for selecting optimization targets and techniques for ORC optimization. Additionally, the study proposes a four-level design approach that considers aspects related to "device" such as ORC architecture, component structure, and working fluid molecules simultaneously. This approach is anticipated to further enhance overall performance and warrants further discussion in future studies (Orc et al., 2021).

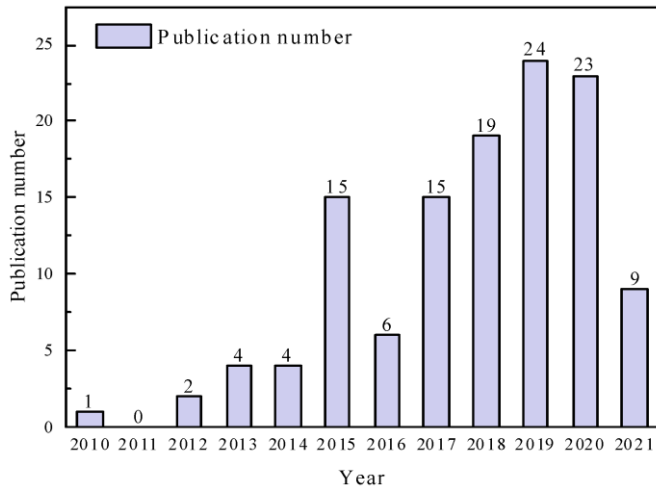

### 3. METHODOLOGY

Figure 1 journal dates from 2010 to 2021.(Orc et al. 2021)

Mathematical Model 3.1 Thermodynamic Analysis of ORC  
 This study utilizes a thermodynamic analysis of the Organic Rankine Cycle (ORC) with a heat exchanger. The schematic diagram of the ORC system, which serves as the basis for the thermodynamic analysis, is presented in Figure 1(a). Furthermore, the corresponding T-s (temperature-entropy) diagram is depicted in Figure 1(b).

Fig. 3.1(a) diagrams of ORC with heat exchanger

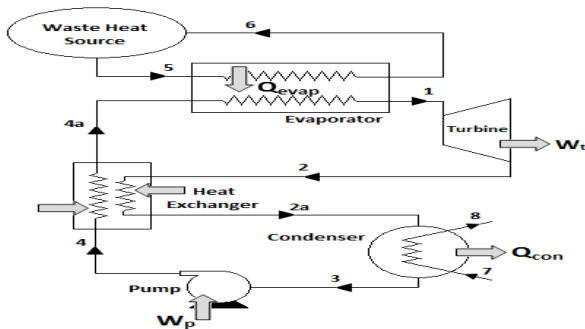

Fig. 3.1(a) diagrams of ORC with heat exchanger

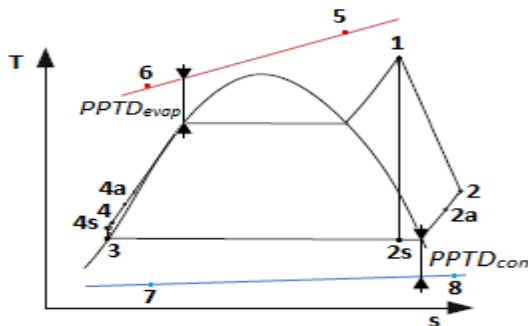

Fig. 3.2 Schematic (b) and T-s

Table 3.1 lists the variables and their values required in analyses.

Parameters and their levels used in calculations.			
Parameters Level	1	2	3
A Working Fluid	R123	R245fa	R600
B PPTDevap	0	10	15
C PPTDcon	0	5	10
D Superheating Temperature, Tsh	0	5	10
E Effectiveness of the Heat Exchanger, εexc	0	0.6	0.75
F Evaporator Temperature, Tevap	100	120	130
G Condenser Temperature, Tcon	30	35	40
H Turbine Efficiency, ηT	0.75	0.8	0.85
I Pump Efficiency, ηp	0.75	0.8	0.9

3.2 Taguchi Method: The proper orthogonal array selection is crucial in Taguchi approach. The total level of freedom (DOF), which may be determined by adding the individual DOF of each element, determines selection. Each factor's DOF is equal to the number of factorial designs minus zero. Table 2 shows that there are nine components (from A to I) and three levels (from 1 to 3), which results in a total DOF number of 26. Fundamentally, the DOF of the chosen orthogonal array is greater than the entire DOF. Consequently, L27 is chosen as the Taguchi orthogonal array in this investigation (3<sup>9</sup>). The Results and Discussion section includes a presentation of the chosen Taguchi orthogonal array.

Table 3.3 lists the S/N ratios and thermal efficiency for the L27 orthogonal array.(Bademlioglu et al. 2018)

Case	Working Fluid	PPTDevap	PPTDco	Superheating Temperature, Tsh	Effectiveness of the Heat Exchanger, εexc	Evaporator Temperature, Tevap	Condenser Temperature, Tcon	Turbine Efficiency, ηT	Pump Efficiency, ηp
1	R123	0	0	0	0	100	30	0.75	0.75
2	R123	0	0	0	0.6	120	35	0.8	0.8
3	R123	0	0	0	0.75	130	40	0.85	0.9
4	R123	10	5	5	0	100	30	0.8	0.8
5	R123	10	5	5	0.6	120	35	0.85	0.9
6	R123	10	5	5	0.75	130	40	0.75	0.75
7	R123	15	10	10	0	100	30	0.85	0.9
8	R123	15	10	10	0.6	120	35	0.75	0.75
9	R123	15	10	10	0.75	130	40	0.8	0.8
10	R245fa	0	0	10	0	120	40	0.75	0.8
11	R245fa	0	0	10	0.6	130	30	0.8	0.9
12	R245fa	0	0	10	0.75	100	35	0.85	0.75
13	R245fa	10	5	0	0	120	40	0.8	0.9
14	R245fa	10	5	0	0.6	130	30	0.85	0.75
15	R245fa	10	5	0	0.75	100	35	0.75	0.8
16	R245fa	15	10	5	0	120	40	0.85	0.75
17	R245fa	15	10	5	0.6	130	30	0.75	0.8
18	R245fa	15	10	5	0.75	100	35	0.8	0.9
19	R600	0	0	5	0	120	35	0.75	0.9
20	R600	0	0	5	0.6	130	40	0.8	0.75
21	R600	0	0	5	0.75	100	30	0.85	0.8
22	R600	10	5	10	0	120	35	0.8	0.75
23	R600	10	5	10	0.6	130	40	0.85	0.8
24	R600	10	5	10	0.75	100	30	0.75	0.9
25	R600	15	10	0	0	120	35	0.85	0.9
26	R600	15	10	0	0.6	130	40	0.75	0.8
27	R600	15	10	0	0.75	100	30	0.8	0.75

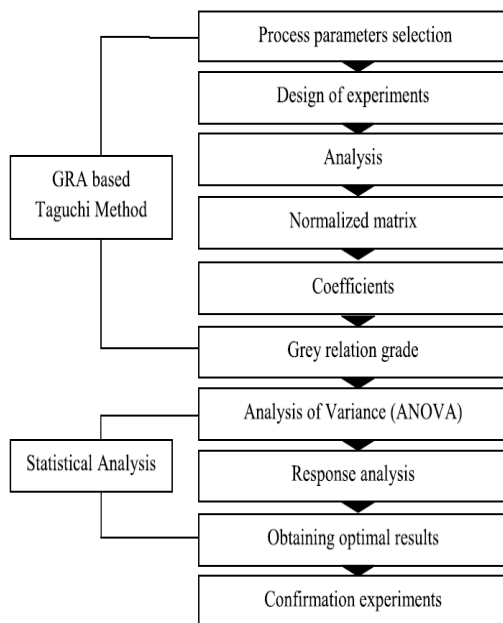

Fig.3.4 Flow chart for analyzing performance characteristics.(Sharma, Aggarwal, and Singh 2020)

Table 3.3 Thermal efficiencies and S/N ratios for the L27 orthogonal array.

PPTDevap	PPTDcon	Superheating Temperature, Tsh	Effectiveness of the Heat ExchE	Evaporat or Temperature, Tevap	Condenser Temperature, Tcon	Turbine Efficiency, ηT	Pump Efficiency, ηp	Thermal Efficiency	SNRA1
0	0	0	0	100	30	0.75	0.75	0.117	-18.6363
0	0	0	0.6	120	35	0.8	0.8	0.145	-16.7427
0	0	0	0.75	130	40	0.85	0.9	0.159	-15.9721
10	5	5	0	100	30	0.8	0.8	0.125	-18.0688
10	5	5	0.6	120	35	0.85	0.9	0.156	-16.1319
10	5	5	0.75	130	40	0.75	0.75	0.143	-16.8751
15	10	10	0	100	30	0.85	0.9	0.133	-17.523
15	10	10	0.6	120	35	0.75	0.75	0.14	-17.0899
15	10	10	0.75	130	40	0.8	0.8	0.155	-16.2046
0	5	10	0	120	40	0.75	0.8	0.116	-18.7408
0	5	10	0.6	130	30	0.8	0.9	0.16	-15.9339
0	5	10	0.75	100	35	0.85	0.75	0.13	-17.7078
10	10	0	0	120	40	0.8	0.9	0.124	-18.1596
10	10	0	0.6	130	30	0.85	0.75	0.161	-15.8797
10	10	0	0.75	100	35	0.75	0.8	0.001	-64.437
15	0	5	0	120	40	0.85	0.75	0.131	-17.6612
15	0	5	0.6	130	30	0.75	0.8	0.146	-16.7011
15	0	5	0.75	100	35	0.8	0.9	0.121	-18.3156
0	10	5	0	130	35	0.75	0.9	0.129	-17.8219
0	10	5	0.6	100	40	0.8	0.75	0.11	-19.1959
0	10	5	0.75	120	30	0.85	0.8	0.16	-15.9339
10	0	10	0	130	35	0.8	0.75	0.136	-17.3228
10	0	10	0.6	100	40	0.85	0.8	0.118	-18.5256
10	0	10	0.75	120	30	0.75	0.9	0.146	-16.6951
15	5	0	0	130	35	0.85	0.8	0.144	-16.8026
15	5	0	0.6	100	40	0.75	0.9	0.102	-19.811
15	5	0	0.75	120	30	0.8	0.75	0.146	-16.6832

### 3.7 Analysis of factors:

Table 3.3 shows the configuration for various input and output parameters using the L15 orthogonal array. The SN ratio should be calculated for each factor to assess the effect of each factor on the responses. The effect on deviations from mean responses was used to determine

the effect on average response and noise, revealing the sensitivity of the experimental output to sound effects. In this analysis, the SN ratio was chosen as the criterion of larger is better' to optimize responses. In this study, it is also a crucial tool to investigate how unconditional elements affect a response. By determining the design parameters that can minimize variation, of variation in the responses through Anova In this study "larger the best" is used as the optimization criteria for specific performance. Variance of the corresponding parameter are compared with residual variance and estimated as mean square of the parameter to the mean square of variance to derive the f value for f test f value is usually taken when it is greater or equal to unity. Fisher test f test with 95% of confidence level less than 0.05 is used to assess the significance of individual parameter on specific performance thermal efficiency.

### 4. DESIGN OF EXPERIMENT

Design of experiment is technique developed to understand the behaviour of the mechanical system. Data are collecting from the sets of the variable, and it can qualitatively explain the undergoing phenomenon. Hence it is well known that aim of any research is design the experiment with minimum number of the experiment and with this experiment collects maximum information as much as possible. Every experiment focuses on the major number of the factor which can directly affect the results of the experiment. And such types of factor can be detected by quantities which have maximum effect on the experiments outcomes. Important concepts for identified such factor is to look after the experiment performed later or by theories.

It is the combination of DOE with optimization of process for required results. It focuses on the effect of variation on the performance characteristics of process. According to Taguchi, proper parameter design should be done during the offline phase. Taguchi performs the following steps: determine the objectives, determine the performance characteristics with measurement tools, determine the factors affecting performance characteristics with their levels and interactions if any, determine the orthogonal array and give the factors at their levels, conduct the tests, analyse the experimental data using the SN ratio, factor effects, and analysis of variance to locate the significant factors with their optimum levels. The mean to standard deviation ratio is known as the S/N ratio. The lower the number, the better, the higher the number, and the nominal the better are the three subdivisions. ANOVA is used to determine which parameter has a substantial impact. The best mix of factors can be discovered using the S/N ratio and ANOVA analysis..(Sharma, Aggarwal, and Singh 2020)



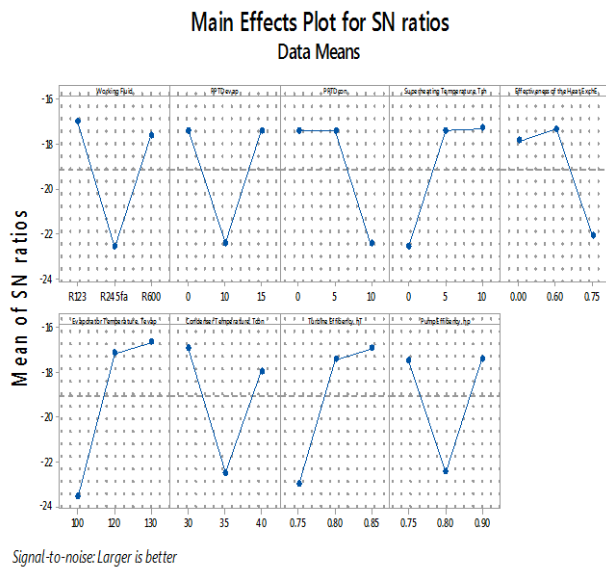

Signal-to-noise: Larger is better

Fig. 4.1 Main Effect plot for SN ratio of each parameter on the thermal efficiency.

Furthermore, the optimum level of design parameters is the level with the maximum S/N ratio. Therefore, working fluid = R123 (A1), PPTDevap = 0°C (B1), PPTDcon = 0°C (C1), Tsh= 10°C (D3), εexc= 0.75 (E3), Tεvap = 130°C (F3), Tcon= 30°C (G1), ηT= 85% (H3) and ηp= 90% (I3) are determined as design parameter optimum values for maximum ORC thermal efficiency. When the optimum condition (A1B1C1D3E3F3G1H3I3) is chosen for ORC thermodynamic analysis, thermal efficiency is calculated as 17.3%, which is the maximum value that can be obtained under these working conditions

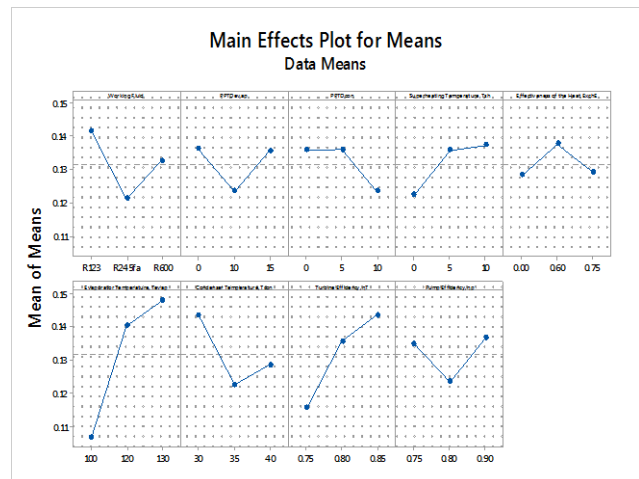

Fig. 4.3 Main Effect plot for Means of each parameter on the thermal efficiency.

Table 4.1 Taguchi Analysis: Thermal Efficiency versus working ... p Efficiency, ηp Response Table for Signal to Noise Ratios

Level	Working Fluid	PPTDevap	PPTDcon	Superheating Temperature, Tsh	Effectiveness of the Heat Exch.	Evaporator Temperature, Tεvap	Condenser Temperature, Tcon	Turbine Efficiency, ηT	Pump Efficiency, ηp
1	-17.03	-17.41	-17.4	-22.57	-17.86	-23.58	-16.89	-22.98	-17.45
2	-22.62	-22.46	-17.42	-17.41	-17.33	-17.09	-22.49	-17.4	-22.46
3	-17.64	-17.42	-22.47	-17.3	-22.09	-16.61	-17.91	-16.9	-17.37
Delta	5.59	5.05	5.07	5.26	4.76	6.97	5.59	6.07	5.09
Rank	4	8	7	5	9	1	3	2	6

Table 4.2 Taguchi Analysis: Thermal Efficiency versus working ... p Efficiency, ηp Response Table for Response Table for Means

Level	Working Fluid	PPTDevap	PPTDcon	Superheating Temperature, Tsh	Effectiveness of the Heat Exch.	Evaporator Temperature, Tεvap	Condenser Temperature, Tcon	Turbine Efficiency, ηT	Pump Efficiency, ηp
1	0.1415	0.1361	0.1357	0.1222	0.1282	0.1064	0.1438	0.1155	0.1349
2	0.121	0.1233	0.1359	0.1356	0.1376	0.1404	0.1225	0.1358	0.1234
3	0.1324	0.1355	0.1234	0.1371	0.1291	0.1481	0.1286	0.1436	0.1366
Delta	0.0205	0.0128	0.0125	0.0149	0.0094	0.0417	0.0213	0.0281	0.0133
Rank	4	7	8	5	9	1	3	2	6

Although this case (A1B1C1D3E2F3G1H3I3) is not among the 27 cases located in Table 4, the highest thermal efficiency is statistically obtained for this case. As seen, the Taguchi method allows determination of the cycle's optimum working condition without calculating each possibility. On the other hand, despite PPTD=0°C is ideal condition for evaporator and condenser; it does not reflect actual operating conditions for the heat exchangers. Since this is a parametric study, the operating ranges were kept as wide as possible. For this reason, the PPTD values are initialized at 0°C. Although the condition of PPTD=0°C is practically impossible, it theoretically gives the best

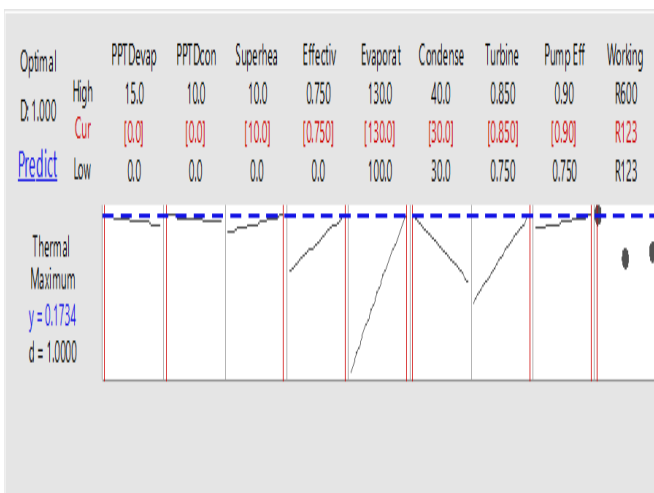

Fig. 4.2 Thermal efficiency analysis by response surface methodology

working condition. In addition to the optimum condition, the worst working condition has been determined as A3B3C3D1E1F1G3H1I1.

### 4.2 GRA-BASED TAGUCHI DESIGN

An L15 orthogonal array is used in the current analysis. Multi-attribute decisions can be obtained using the grey relational analysis technique. The experimental results for thermal efficiency and machining force in GRA are normalised to a number between 0 and 1. The information for thermal efficiency is expressed as maximum values for all objective functions. The higher is better. Thermal efficiency is maximum and stated as if the response is to be maximum, then higher the better qualities is meant for normalisation to scale it into an acceptable range using the following formula variation.

$$y_i(k) = \frac{x_i(k) - \min x_i(k)}{\max x_i(k) - \min x_i(k)}$$

11(1)

Where  $y_i(k)$  indicates the normalization value of grey relational generation,  $\max x_i(k)$  and  $\min x_i(k)$  express the maximum and minimum value of  $x_i(k)$ , respectively. Lastly,  $x_i(k)$  represents the optimum value.

Table 4.6 Normalized results, grey relational coefficients, grey relational grade and order.

Case	$\eta_I$	Normalized	Deviatin sequence	Grey Relation Coefficient	Grey Relation Grade	RANK
1	0.117	0.7270	0.2730	0.6469	0.3234	23
2	0.1455	0.9051	0.0949	0.8404	0.4202	10
3	0.159	0.9894	0.0106	0.9792	0.4896	4
4	0.1249	0.7764	0.2236	0.6910	0.3455	19
5	0.1561	0.9713	0.0287	0.9457	0.4728	5
6	0.1433	0.8913	0.1087	0.8214	0.4107	12
7	0.133	0.8270	0.1730	0.7429	0.3715	15
8	0.1398	0.8695	0.1305	0.7930	0.3965	13
9	0.1548	0.9631	0.0369	0.9314	0.4657	6
10	0.1156	0.7183	0.2817	0.6396	0.3198	24
11	0.1597	0.9938	0.0062	0.9877	0.4938	2
12	0.1302	0.8095	0.1905	0.7241	0.3621	17
13	0.1236	0.7683	0.2317	0.6833	0.3417	20
14	0.1607	1.0000	0.0000	1.0000	0.5000	1
15	0.0006	0.0000	1.0000	0.3333	0.1667	27
16	0.1309	0.8139	0.1861	0.7287	0.3644	16
17	0.1462	0.9094	0.0906	0.8466	0.4233	9
18	0.1214	0.7545	0.2455	0.6707	0.3354	21
19	0.1285	0.7989	0.2011	0.7131	0.3566	18
20	0.1097	0.6814	0.3186	0.6108	0.3054	25
21	0.1597	0.9938	0.0062	0.9877	0.4938	2
22	0.1361	0.8463	0.1537	0.7649	0.3825	14
23	0.1185	0.7364	0.2636	0.6548	0.3274	22
24	0.1463	0.9101	0.0899	0.8475	0.4238	8
25	0.1445	0.8988	0.1012	0.8317	0.4158	11
26	0.1022	0.6346	0.3654	0.5778	0.2889	26
27	0.1465	0.9113	0.0887	0.8493	0.4247	7
MAX	0.1607	1.0000	1.0000			
MIN	0.0006	0	0			

Table 4.7 Mean S/N ratios and weight factor for the first law efficiency.

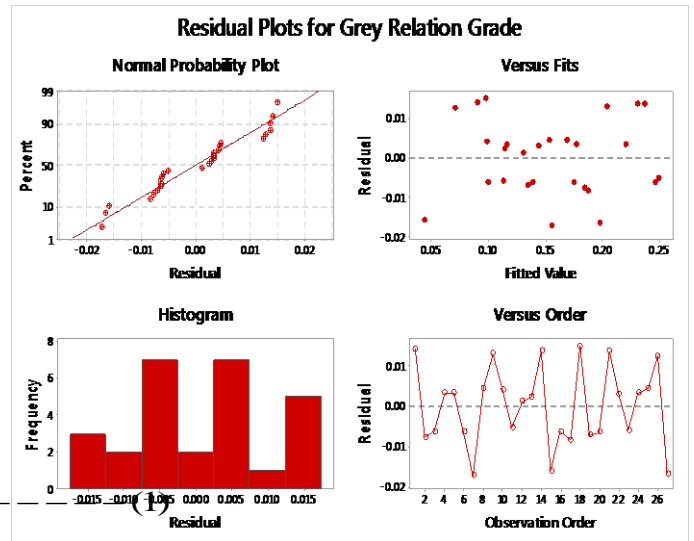

Fig. 5.4 Residual plot for Grey Relation Grade

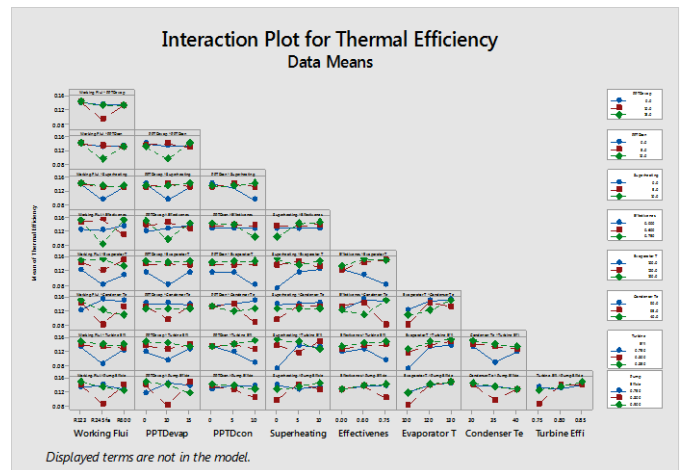

Fig. 5.5 Interaction Plot for thermal efficiency

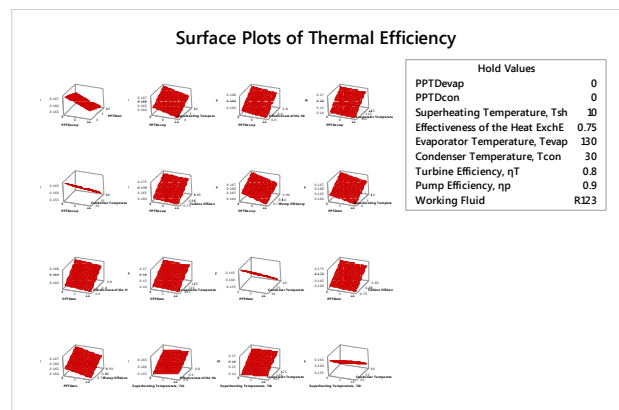

Fig. 5.6 Surface Plot for thermal efficiency.

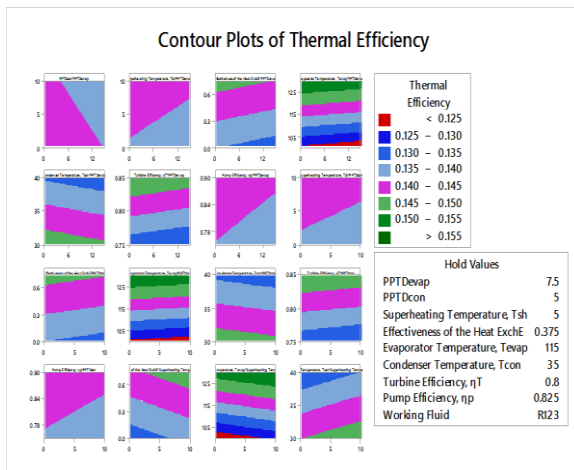

Fig. 5.6 Contour Plot for thermal efficiency

Table: 4.8 ANOVA table for grey relational grade

Additionally, Grey relation analysis method is implemented as an optimization technique for maximizing the first law efficiencies simultaneously. Evaporator temperature, turbine efficiency, heat exchanger effectiveness, and condenser temperature are derived as the primary process parameters from the Grey relation analysis, and the impact ratios of these parameters are estimated as 48.90.37%, 17.43%, 10.80%, and 12.32%, respectively. The optimum and worst operating conditions for ORC are identified as A1B1C3D3E3F3G1H3I3 and A3B3C1D1E1F1G3H1I1, respectively, after taking into account several performance characteristics. The optimal condition presents the highest first law efficiencies. Within the range of analysed operating conditions, the system's first law efficiencies are found to be 17.3% for the best case. The first are found to be 9.6% for the worst condition.

### CONCLUSION

1. The investigation of grey relation method is implemented as an optimization technique for maximizing the first law efficiencies simultaneously. Evaporator temperature, turbine efficiency, heat exchanger effectiveness, and condenser temperature are derived as the primary process parameters from the Grey relation analysis, and the impact ratios of these parameters are estimated as 48.90.37%, 17.43%, 10.80%, and 12.32%, respectively.
2. The optimum and worst operating conditions for ORC are identified as A1B1C3D3E3F3G1H3I3 and A3B3C1D1E1F1G3H1I1, respectively, within the range of analysed operating conditions, the system's first law efficiencies determined to be 17.3% for the best case. The first observed to be 9.6% for the worst condition. This study lists the

ORC process parameters that are effective and ineffective as well as their statistical impact weight rankings.

3. the optimum level of design parameters is the level with the maximum S/N ratio. Therefore, working fluid = R123 (A1), PPTDevap = 0°C (B1), PPTDcon = 0°C (C1), Tsh= 10°C (D3), εexc= 0.75 (E3), Tevap = 130°C (F3), Tcon= 30°C (G1), ηT= 85% (H3) and ηp= 90% (I3) are determined as design parameter optimum values for maximum ORC thermal efficiency. When the optimum condition (A1B1C1D3E3F3G1H3I3) is chosen for ORC thermodynamic analysis, thermal efficiency is calculated as 17.3%, which is the maximum value that can be obtained under these working conditions
4. The value for the R –sq is 91.51% which is good agreement between the input and the output relationship. It shows that there is strong relationship between the input and the output variables. Now the value of the R-Sq (adj) = 92.04%hence the data are well fitted for the new sets of the variables
5. Statistically, F-test decides whether the parameters are significantly different. A larger F value shows the greater impact on the Evaporator Temperature, Tevap performance characteristics [15]. Larger F values are observed for Evaporator Temperature (P=0.00) (51.67 %)

### Reference:

1. Abdellah, Youcef et al. 2021. "Towards Improvement of Waste Heat Recovery Systems: A Multi-Objective Optimization of Different Organic Rankine Cycle Configurations." *International Journal of Thermofluids*: 100100. <https://doi.org/10.1016/j.ijft.2021.100100>.
2. Annuar, Arbainah Shamsul et al. 2021. "Jo Ur l P Re." *Carbohydrate Polymers*: 118159. <https://doi.org/10.1016/j.carbpol.2021.118159>.
3. Authors, For. 2017. "Grey Systems: Theory and Application Article Information :"
4. Bademlioglu, A H, A S Canbolat, and O Kaynakli. 2020. "Multi-Objective Optimization of Parameters Affecting Organic Rankine Cycle Performance Characteristics with Taguchi-Grey Relational Analysis." *Renewable and Sustainable Energy Reviews* 117(March 2019): 109483. <https://doi.org/10.1016/j.rser.2019.109483>.

5. Bademlioglu, A H, A S Canbolat, N Yamankaradeniz, and O Kaynakli. 2018. "Investigation of Parameters Affecting Organic Rankine Cycle Efficiency by Using Taguchi and ANOVA Methods." *Applied Thermal Engineering*. <https://doi.org/10.1016/j.applthermaleng.2018.09.032>.
6. Ehyaei, E Ghasemian M A. 2017. "Evaluation and Optimization of Organic Rankine Cycle ( ORC ) with Algorithms NSGA-II , MOPSO , and MOEA for Eight Coolant Fluids." *International Journal of Energy and Environmental Engineering*.
7. Gimelli, A, A Luongo, and M Muccillo. 2016. "EFFICIENCY AND COST OPTIMIZATION OF A REGENERATIVE ORGANIC RANKINE CYCLE POWER PLANT THROUGH THE MULTI-OBJECTIVE APPROACH." *Applied Thermal Engineering*. <http://dx.doi.org/10.1016/j.applthermaleng.2016.12.009>.
8. Goyal, Ashwni, Ahmad Faizan Sherwani, and Deepak Tiwari. 2019. "Environmental Effects Optimization of Cyclic Parameters for ORC System Using Response Surface Methodology ( RSM )." *Energy Sources, Part A: Recovery, Utilization, and Environmental Effects* 0(00): 1-14. <https://doi.org/10.1080/15567036.2019.1633443>.
9. Heberle, Florian, and Dieter Brüggemann. 2010. "Exergy Based Fluid Selection for a Geothermal Organic Rankine Cycle for Combined Heat and Power Generation." 30: 1326-32.
10. Le, Van Long, Abdelhamid Kheiri, Michel Feidt, and Sandrine Pelloux-prayer. 2014. "Thermodynamic and Economic Optimizations of a Waste Heat to Power Plant Driven by a Subcritical ORC ( Organic Rankine Cycle ) Using Pure or Zeotropic Working Fluid." *Energy*. <http://dx.doi.org/10.1016/j.energy.2014.10.051>.