NOVEL METHODS AND MATERIALS FOR CONCRETE FLOOR SLAB CONSTRUCTION FOR SMALL FAMILY HOUSING BUILDINGS IN INDIA

Srimaruthi Jonnalagadda¹, Sitaram Vemuri²

¹Honorary Professor, Department of Civil Engineering, V R Siddhartha Engineering College, Vijayawada, AP, India

²Structural Engineer, Assystem Stup

ABSTRACT

This work is a natural follow-up for the previous work from the authors about the state of slab construction for single family housing units in India. A need to replace traditional cast-in-place construction with alternate materials and methods was concluded at the end of that previous study. In this paper, the authors enlist various alternate slab members and construction methods that are tried and tested both in research and industry circles in the US and European construction markets. Each of the alternate methods are elaborately discussed with their background and methods of engineering and construction. The advantages as well as the suitability of each of the methods to Indian small family housing markets are outlined. Any limitations and shortcomings are discussed. Finally conclusions are made about the need to conduct research to customize each of these methods and products to the specific requirements, conditions and standards of the Indian small family housing construction industry.

KEY WORDS: cast-in-place, concrete, composite, deck-panel, double-tee, hollow-core, home, India, precast, slab, steel, ultrahigh-performance-concrete, UHPC, waffle

INTRODUCTION AND BACKGROUND

A vast majority of floor slabs in housing buildings in India are constructed using traditional cast-in-place (TCIP) slab method. The construction sequence, the casting and curing procedures and the quality processes are elaborately detailed in the authors' previously published work [1]. The challenges associated with TCIP construction are also discussed in that work. The authors' concluded in that work that this method of construction is not relevant to the current socio-economic context in India anymore because it is resulting in poor economy and quality of construction. It was suggested that there is critical need for Indian builders, engineers and owners of single family housing units to consider new methods of construction on a large scale. In this paper, the authors continue on their previous work to put forward some of the novel construction methods, members and materials that are available in markets abroad. These methods have evolved through years of research and experimentation by academia and industry as well as implemented by engineers in real construction projects.

The paper starts with introduction to precast concrete solid slab members, and the process of manufacture, transport and member erection at job site with quality and speed. Precast hollow-core slab members which are very popular in US and Canadian markets are discussed. The waffled precast slab option which provides significant stiffness but yet consumes less concrete is presented as one of the options. This is followed by a very popular precast double-tee members that are very commonly used for majority of parking garages.

There is a very good reason to re-create these Double-Tee (DT) member geometry and design to make them good candidates for floor slab members for housing units in India. The DT slab option is followed by looking at the promising new material of Ultra-High-Performance-Concrete (UHPC) and the excellent opportunities it creates in the design and construction of very strong and durable concrete slab members. As another possible alternative, the composite steel-concrete composite slab construction using structural steel as material of construction is also presented. The objective of the authors is to present the various proven alternatives to cast-in-place slab and educate the engineers and especially the builders and owners of single family homes in India to adapt to the available modern methods and materials of construction.

In the following section, each of these methods and material are discussed in detail along with advantages of the method over traditional cast-in-place slab method. Any limitations in the application of these methods to Indian housing markets is

highlighted. Finally, some conclusive thoughts about the alternate methods of construction of floor slabs and the improvements they could bring to single family housing units in India are summarized at the end of this manuscript.

NOVEL METHODS AND MATERIALS FOR CONCRETE SLAB CONSTRUCTION

In the section, the author outlines some alternate methods and materials of construction that evolved around the world. Some of these alternatives have been proven already in other markets within the country as well as outside internationally whereas some are relatively new and still evolving. Extensive research is being done across the world in academic circles as well as industry to develop, test and produce more efficient and economic design and construction methods. The most feasible alternatives are suggested and discussed here.

Because TCIP floor slab construction is the most rigorous and demanding of all construction activities in terms of economy and efficiency, the author placed his emphasis on floor slabs while making his recommendations for alternate methods and materials. It is believed that any of these methods and materials will provide significant advantage in improving construction quality, speeding up construction timelines, and achieving major savings in construction costs.

I. PRECAST SOLID CONCRETE SLAB

Precast concrete construction has become popular around the world for projects of any scale and size. Precast concrete construction provides opportunity for controlled mass production of concrete members in factory setting where rigorous quality controls are in place to ensure manufacture of concrete members with quality. Precast concrete plants are equipped with automated batching units that use calibrated scales to batch materials exactly as per design mix proportions and adhere to mixing times and procedures to ensure high quality concrete production as design per specifications. The members are cast on cleaned and oiled form work, allowed to set and are stripped out of the form beds when they achieve required strength. The members are then moved to storage yard and verified for geometry and inspected for any cracks, spalls or missing inserts such as plates, hooks etc. Remedial measures are taken if required. All this is done within the factory premises and as such all the quality is achieved well before the members are moved to the project site. The controlled factory production of members under established procedures greatly improves the quality of concrete members and significantly cuts down serviceability issues which are more often reported in TCIP construction.

Precast construction greatly reduces the risk of delay in projects as member production often can start at factory independent of project site issues. Also, the manufacture processes are streamlined well in factory setting, precast member production has cost advantage over TCIP construction. The construction materials, formwork, reinforcement, finish materials, inserts, hooks, plates, prestress strands all are usually well stocked ahead of the project. Only special materials that are specific to the project need to be procured separately.



Figure 1: Precast solid slab stripped out of precast bed (top left), precast building erection (top right), tying reinforcement on the form bed in plant (bottom left), erection of slab at job site (bottom right) , Picture from PCI 8th Edition [2]

With all these inherent advantages precast concrete construction can be a natural choice of construction method. However, precast concrete construction did not find its place yet in typical small family residential housing in India. Though this is mainly due the mind set and lack of knowledge and training of builders in this method of construction, some of it can be attributed to other causes as well. Because precast concrete members are manufactured at factory and transported to the job site, there is a need for good road infrastructure. The roads in urban and sub-urban neighborhoods are seldom wide enough to enable maneuver of trucks and crane operations. One fundamental engineering requirement of precast concrete construction is the robust design and construction of joints. It can be said that the strength of a precast structure is the strength of its joints. Ensuring strict adherence to material specifications, welding specifications and inspection and quality assurance procedures is primary to successful construction of precast concrete structures. There is not enough awareness of these procedures and their importance, as such precast concrete construction has not gained traction. It is a bit weird to note that precast bridges are more commonly built in India than precast single family buildings even though bridges experience much larger forces than single family buildings.

II. PRECAST HOLLOW-CORE SLAB

These are precast slabs cast with hollow spaces inside them to reduce the overall volume of concrete and reduce the self weight of the slabs. Many precast manufacturers produce these hollow core slabs across the world. They provide good thermal and sound insulation which make them a good choice for floor slabs in single family homes. Hollow core slabs are produced using extruder machines. These slabs can be prestressed. The production process is similar to that of solid slabs except that extruder machines create voids inside the slabs during the process of pouring fresh concrete on tensioned prestressed strands. These hollow core slabs also combine all the advantages of precast manufacturing such as high quality control and durability. The PCI standard tables list hollow core designs for slab thicknesses of 6" to 12" (150mm – 300mm) for variable spans up to 46ft (14m).



Figure 2: Precast hollow-core slabs stacked at yard and jobsite, PCI, 2017 [2]

The hollow-core slabs are a great option for floor slabs in housing units. Being light in weight, they increase structural efficiency of the members and carry higher loads than traditional solid slabs. Quick design tables make it easy to design and fabricate these members in a short notice. These are popular floor slab choice in many countries. Combined with cast-in-place topping, various structural span arrangements are possible with these hollow-core slab systems.

III. PRECAST WAFFLE SLAB

Waffled slabs are thin slabs spanning between ribs that are spaced at regular intervals. The ribs provide the necessary strength and stiffness to the slab system. As such waffle slabs provide great reduction in concrete volume and weight of the slab members. The reduction in concrete volume means reduced amount of steel reinforcement. These slabs are an economical option while providing a similar level of strength and serviceability as solid slabs. The figure 3 below shows a waffled slab floor system that reported a 55% less concrete volume compared to that of solid slab.



Figure 3 : Waffled floor slabs [3]

The presence of bi-directional ribs within the slab makes casting of these members a difficult task. Onsite construction will need large amounts of formwork and as such nullifies the material savings from low concrete volume required for these slabs. However, precast waffled slabs are a great option as preparing the form work at precast plant is a one-time effort and then the process can be standardized for manufacture of these slabs on a regular basis. The presence of bi-directional ribs make these slabs stiff due to the integral structural action similar to that of a beam-slab member and as such only need thinner slabs as compared to solid slab options.

The waffled structure also provides space for electrical fixtures, utility pipelines, and artistic piece of work. The slabs come with all advantages of precast concrete products. Precast waffled slabs can be manufactured with excellent quality and form finish and as such do not need any further layer of cement plaster finishes on them.

IV. PRECAST DOUBLE TEE SLAB

A Double Tee (DT) is a beam-slab member that is made of two stems and a flange slab. Precast DT members are highly optimized, tried, tested and very popular in many countries. The design and construction of beam slab systems using these members is well documented. PCI provides standard geometry, reinforcement, loads and designs for these members for both totally precast members. These members can also be designed with about 1-3 inches (or 25-75mm) thick layer of cast-in-place field concrete topping on precast double tee members. The cast-in-place topping ensures composite slab strength, durability and water tightness to the system. However, these standard designs and details are all tailored to North American markets and are not relevant for use in Indian markets as housing floor slabs members.



Figure 4 : DT member fabrication, stripping, storage and transport (PCI MNL-120-17)

One novel idea of the author is to develop a standard precast DT geometry, reinforcement pattern and design that suits the floor slab needs of typical housing unit floors in India. One of the fundamental requirements for developing this standard design DT is to identify the market conditions, load demands, construction preferences, transportation and handling

constraints, precast plant preferences, and local highway infrastructure truck size and load restrictions. A market research was conducted by Ram [4] to identify the precast market conditions where in several precast plant owners and engineers were interviewed. In these interviews, it was attempted to identify the truck sizes, transportation and handling capabilities, limitations, and construction preferences of the precast manufacturers. The survey results provided helpful inputs that aided in identifying standard precast DT design that suits Indian conditions. A step towards this idea can be a major contribution to promoting precast DT member production in India. This can have major impact on the economy and efficiency of housing construction in India. The improved efficiencies will pave way towards sustainable construction and promotes environmental sustainability which is fast becoming a very important aspect in selecting materials and methods for construction as advocated by Jonnalagadda et al [5].

There are some researched variants of DT members that provide even higher efficiency in terms of material cost and economy. The lightweight concrete DT members is one variant wherein lightweight concrete made of lightweight aggregate is used for the manufacture of these members. The density of light weight concrete is about 20-40% less than normal weight concrete. The lightweight material also offers good thermal resistance.

Another variant is the foam void DT members where in cellulose plastic foam is used to create voids in the stems of DT members near low demand regions was developed by Jonnalagadda et al [6]. This helps cut down the volume and weight of these DT concrete members from 10 to 15%. The reduction in self weight of the members can be of advantage in transportation and erection operations.

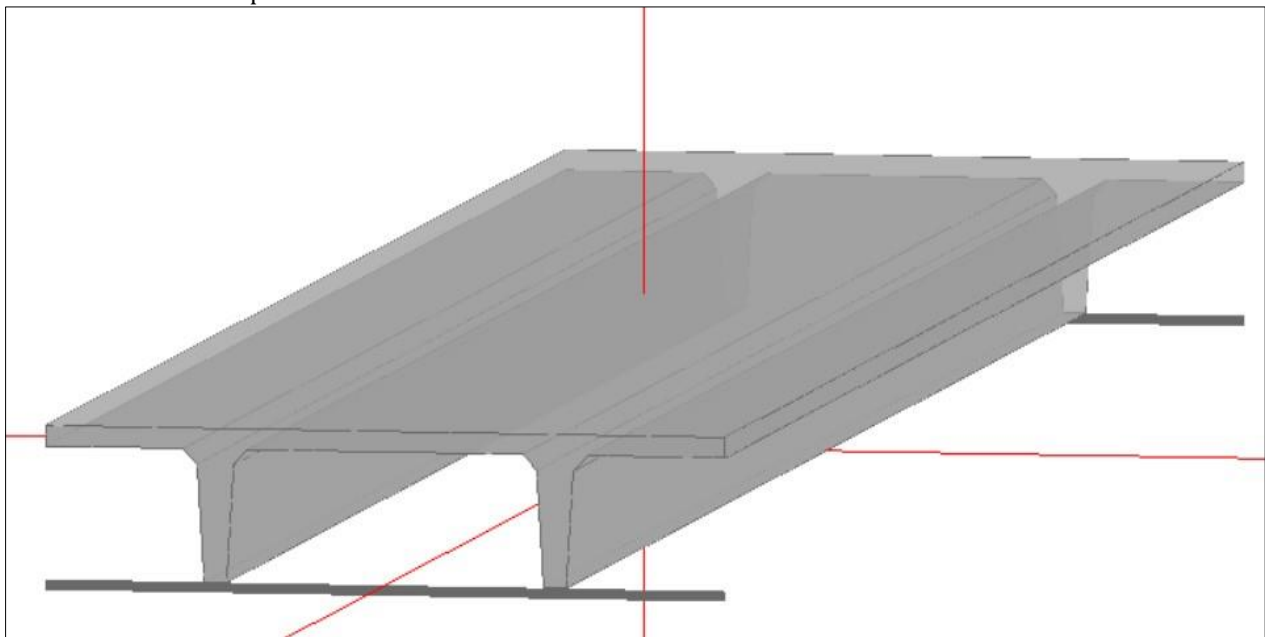

Figure 5 : 3D model of DT member in finite element modeling software

V. UHPC CONCRETE SLAB

Ultra-high performance concrete (UHPC) products have great strength and serviceability characteristics in addition to special properties such as resilience, impermeability, high tensile strength, and strain hardening [7]. These superior properties are expected to make UHPC the most sought-after concrete material in the foreseeable future. These members have a minimum compressive strength of 150 MPa (22 KSI) and a modulus of rupture value of about 10MPa (1.5 KSI) as per ACI 239R [8] guidelines. By virtue of their high compressive, tensile and shear capacity, UHPC products are thinner and lighter. This brings down their self weight dead loads significantly. In addition, light weight members are easier to manufacture, less expensive to transport from precast plant to job site and quicker to erect during construction. UHPC precast products substantially improve efficiency in economy of construction by reducing costs, improving quality, and shortening construction duration.

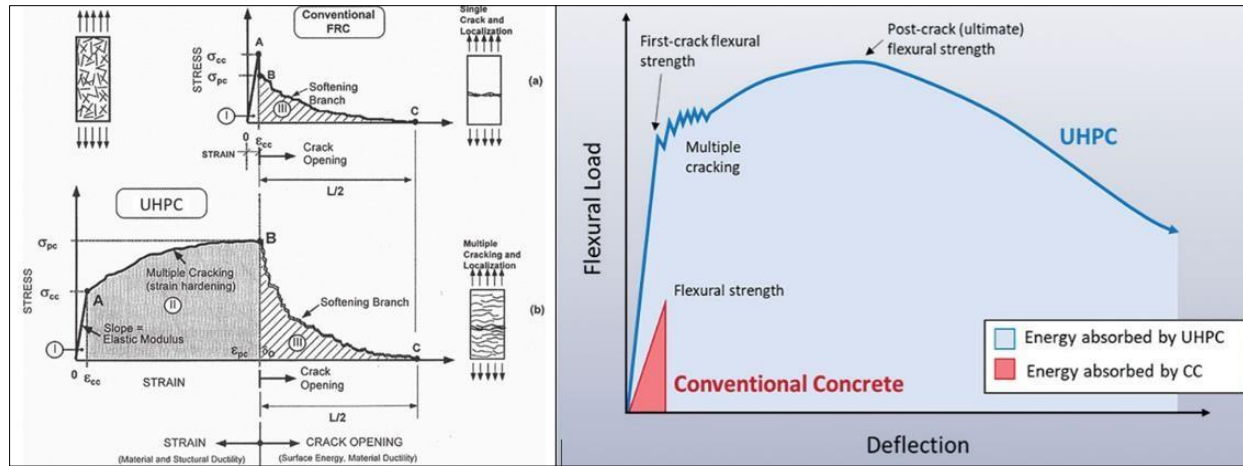

Figure 6 : Comparative behavior of UHPC & Conventional Concrete (ACI 239R-18)

As can be seen in figure 6, UHPC has significantly higher energy absorption capacity than that of conventional concrete. The compressive strength, tensile strength, modulus of elasticity, stiffness, and fatigue strength of UHPC are substantially higher than conventional concretes. Proprietary UHPC concrete mixes (such as Ductal®) have high cost to them, so it is recommended to develop mix proportions based on local ingredients after experimental investigations using trial mixes. Addition of steel fibers and need for special mechanical mixers and longer mix duration can add significant cost to the manufacture of concrete. However, the higher cost of UHPC can be offset by savings in steel and concrete because UHPC designs lead to lighter concrete members with practically very minimal steel in them.

UHPC concrete is a very emerging technology. Though some structures have been built in France, Japan, South Korea, Malaysia, USA, Canada and few other countries, not many countries have developed code specifications and designs for UHP concrete strength and properties. Also, the properties of the concrete are very sensitive to ingredients, mix proportions and construction methods. In the United States, a novel research funded by the Nebraska transportation center resulted in thinner webs and lighter geometries using prestressed UHP concrete bridge girders [9]. This material is promising to handle fatigue in structures such as tall buildings that see significant wind or seismic lateral forces [10].

There are no known set of fully developed Indian Standards (IS) code specifications or practice of design or construction for UHPC based concrete member designs within the knowledge of the authors. Any research towards development of a standard UHPC slab for residential single family floor slabs will be extremely useful in achieving significant economy as well as improving the quality of house construction in India.

VI. STEEL-CONCRETE COMPOSITE DECK SLAB

Steel metal decks with steel shear studs projected to receive composite cast-in-place concrete topping slab is common in the construction of bridge decks across the world. This method of construction is also popular in building large column-free floor and roof systems for warehouses and stores. This method has the benefits of quick erection without formwork requirement. Standard steel roof deck sheets are available in variable thickness to suit the span of the roof. These are factory manufactured. These steel roof decks are erected on truss beams spanning on corbels of columns or walls. The steel roof decks provide the necessary permanent formwork for fresh concrete and are designed to take construction material and labor loads in addition to fresh concrete weight. The steel decks have built-in shear studs projecting on top of them. When ready, fresh concrete is poured on top of the steel deck. Upon hardening the composite steel-concrete slab acts together to receive live loads on the floor.

The interface shear due to live loads is carried by the shear studs which are designed for their size and spacing. Some steel deck systems use folded plate structure when filled with concrete acts like pockets to transfer interface shear without need for studs. The steel deck works as positive moment reinforcement in the overall finished floor and as such reduces the overall steel

requirement in the slab significantly. American National Standards Institute (ANSI) standard C-2017 provides design guidelines for the construction of composite steel deck floor slabs.

Figure 7 shows bridge girders with stay in form steel metal decks spanning the girders. The picture also shows shear studs projected to receive cast-in-place concrete slabs. As such this method can be one good alternative for TCIP construction in India. This method rules out the need for arduous formwork (required to pour fresh concrete slab) which accounts for a large portion of time and cost in TCIP method of slab construction. This also significantly improves the quality of construction because many quality issues in TCIP construction stem from poor formwork and the associated labor and schedule problems.

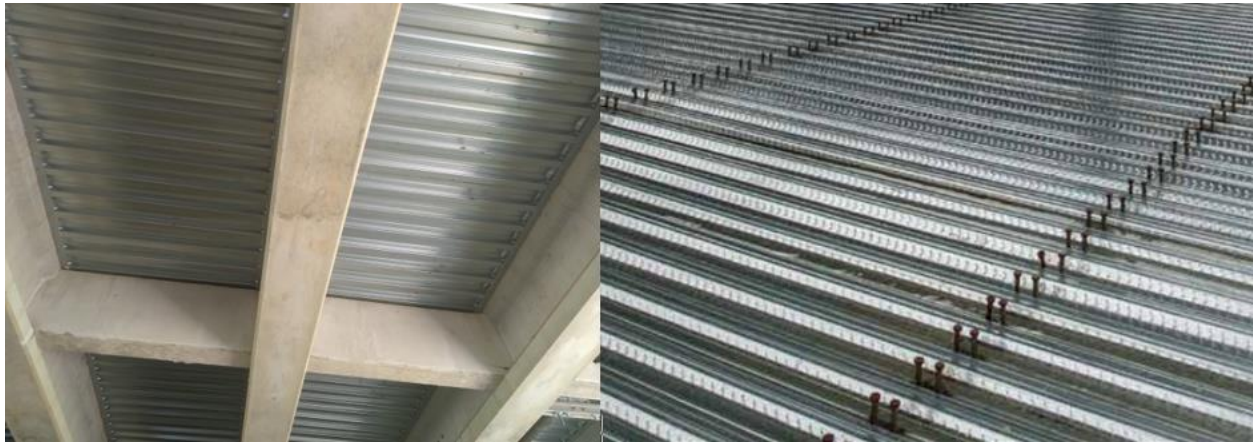

Figure 7: Steel-form partial deck on beams with studs projecting for composite concrete

CONCLUSIONS

It was concluded in the authors' previous research that the traditional cast-in-place reinforced concrete slab construction for small family housing units in India is inefficient and uneconomic for the current socio-economic conditions. In this follow-up article, the authors suggested some modern novel slab construction methods that can substitute the traditional cast-in-place slab construction. The authors provided a detailed background of the alternate novel slabs systems, methods and materials and elaborated on their implementation and advantages. Most of these methods are an outcome of thorough research over the last few decades and tried and tested by construction industry and housing builders in developed countries. Some methods like precast UHP concrete construction are still not well documented and the complete analysis and design procedures are not available within code specifications developed by Indian Standards. To conclude, the authors believe that all the alternate methods covered in this study have great potential as choice for slab construction in small family housing units in India. The authors strongly opine that significant research is required to develop custom construction and engineering procedures that are tailored to manufacturing, transportation, construction, engineering and design standards as followed in India.

REFERENCES

- 1) Srimaruthi Jonnalagadda., and Sitaram Vemuri. 2023. "Challenges in Traditional Concrete Slab Construction for Housing Buildings in Developing Countries and Critical Need for Novel Methods." *International Journal of Advances in Engineering and Management.*, 5(5), 176-186
- 2) PCI Industry Handbook Committee. (2017). PCI Design Handbook: Precast and Prestressed Concrete. MNL-120. 8th ed. Chicago, IL: PCI
- 3) Stott, R. (2015). "This Innovative Concrete Slab System Uses up to 55% Less Concrete" 23 Dec 2015. ArchDaily. Accessed 18 May 2022. <<https://www.archdaily.com/779340/this-innovative-concrete-slab-system-uses-up-to-55percent-less-concrete>> ISSN 0719-8884

- 4) Ram, G. P. (2021). Background of Double Tee Construction and Need for Standardized Precast Double Tee for Indian Building Industry. *Turkish Journal of Computer and Mathematics Education (TURCOMAT)*, 12(11), 2978-2989
- 5) Jonnalagadda, S. 2016. "Artificial Neural Networks, Non Linear Auto Regression Networks (NARX) and Causal Loop Diagram Approaches for Modelling Bridge Infrastructure Conditions" (2016). All Dissertations. 1725. https://tigerprints.clemson.edu/all_dissertations/1725
- 6) Jonnalagadda, S., Sreedhara, S., Soltani, M., & Ross, B. E. (2021). Foam-void precast concrete double-tee members. *PCI Journal*, 66(1).
- 7) Binard, J. P. (2017). UHPC: A game-changing material for PCI bridge producers. *PCI Journal*.
- 8) ACI Committee 239R. (2018). "Ultra-High-Performance Concrete: An Emerging Technology Report", American Concrete Institute, Farmington Hills, MI
- 9) Tadros, M. K., & Morcous, G. (2009). *Application of ultra-high performance concrete to bridge girders* (No. SPR-P1 (08) P310). Nebraska Transportation Center
- 10) Sitaram Vemuri., and Srimaruthi Jonnalagadda. 2023. "Wind Analysis of Tall Buildings Using Codal Provisions, Stochastic Approach and CFD–A Comparative Study." *International Journal of Advances in Engineering and Management.*, 5(7), 58-68.