

# Design and impact analysis of an Automotive Frame

Nishant Nanwani<sup>1</sup>, Tanmay Kadam<sup>2</sup>, Karan Kataria<sup>3</sup>, Omkar Koratkar<sup>4</sup>

<sup>1</sup>Dhole Patil college of engineering, Kharadi, Pune 412207, India

<sup>2</sup>Dhole Patil college of engineering, Kharadi, Pune 412207, India

<sup>3</sup>Professor Bhushan Karamkar, Dept. of Automobile Engineering, Dhole Patil college of engineering, Pune, India

\*\*\*

**Abstract** - The Automotive Frame has and always remains the most essential component of any Vehicle and its main supporting backbone. Major components and systems of a vehicle are mounted on it such as the Engine, Powertrain i.e Gearbox, Differential, axles, and the suspension system which hugely depends on the vehicle frame and its strength, rigidity and durability. The frame is also required to provide protection in case of a collision and therefore should be accommodating in absorbing the impact's energy effectively without major deflections causing serious damage to the vehicle cabin and its passengers. A well-designed frame enhances the vehicle's overall performance, efficiency, and driving pleasure in addition to its structural integrity.

To help aid the above concerns, nowadays manufacturers use FEA softwares to analyse and simulate the event of an impact with varying parameters to see how well their frame design fairs and allows them to make necessary changes easily in the model and test again. This method reduces the testing costs greatly and allows researchers to find the perfect solution and optimal design to be further sent for building a successful prototype.

In this study a ladder frame of a Toyota Tacoma 85' has been designed with the help of Solidworks and further impact analysis has been carried out with the help of ANSYS software.

With modern day advancements in the manufacturing and materials field, a number of valid and affordable materials can be chosen as an alternative to conventional use of aluminium and steel for a frame design such as composite materials and alloys.

Carbon epoxy, Magnesium Alloy (AZ31B), Aluminium alloy, structural steel and Stainless steel have been considered to be used as frame material undergoing impact analysis and their results of maximum stress, strain and total deformation are compared along with their weight.

**Key Words:** Impact analysis, Design, Ladder frame, FEA, Carbon epoxy, Magnesium alloy AZ31B, Aluminium alloy, Structural steel, Stainless steel.

## 1. INTRODUCTION

The Automotive Frame, also widely known as Chassis, is a vital structure of a vehicle that forms its backbone on which various systems and devices are mounted all together to make one complete unit. Additionally the frame is responsible for carrying the load of the passengers and systems while handling the sudden braking and acceleration forces and also the stresses involved due to many road irregularities.

Between the period 1896-1910, vehicles used the traditional horse carriage as their support with members being made of wood and reinforced by wrought iron brackets. Shortly after the Ford model T was introduced with a ladder frame and became the popular choice of vehicle due to its robust build and lower cost due to mass manufacturing.

Alongside this advancements were made and new frame designs developed such as the Backbone chassis, X-frame, Platform frame, Perimeter Frame and finally the unibody in 1960 now widely known as monocoque frame.

The ladder frame as the name suggests resembles the shape of a ladder with two long symmetrical beams or rails running on both sides consisting of cross members between to help support the vehicle cabin, systems and shell. Due to the floor pan sitting above the frame, the overall height of the vehicle was increased leading to a higher and undesirable CG (Centre of Gravity) compromising handling. Additionally this frame was also more stiff, heavy to use in sedans and hatchbacks and had poor resistance to torsion, causing manufacturers to use Backbone or Perimeter frames instead. Despite this the Ladder frame is still used widely in modern day SUVs, Pickup Trucks, busses and Trucks due to their strength, agility, flexibility, lower manufacturing costs and their simplicity, making them perfect for off roading usage.

The 1904 Fiat 60 HP and the 1924 Bugatti Type 35 are two prominent early 20th-century vehicles that used backbone chassis. The design has been used by producers including Lotus, Ariel, and Ducati more recently. This chassis has a rectangular cross sectional tubular structure connecting both the front and rear axles with the shape of the human

spine, hence the name Backbone frame. Furthermore the absence of multiple cross members allows for freedom of vehicle shape customization. This frame featured better axle connectivity and ground stability. The backbone frame has drawbacks with respect to the fitment of engine, transmission and similar systems due to its central location which also has lack of lateral support which negatively affects the vehicles handling and safety.

The unibody chassis forms the overall shape of the vehicle and is made by various metal sheets and sections which are welded together to make a single unit on which all the systems of the vehicle are mounted. Most importantly, unibody frames are light in weight therefore improving the vehicle fuel economy. As the components and cabin space is built around it rather than over it, this helps lower the vehicle height and CG ( Centre of Gravity) leading to improved handling and ride quality.

A thorough understanding of material science, engineering concepts, and production procedures is necessary for designing an automobile frame. During operation, automotive frames are subjected to a variety of forces and impacts, including torsional stress, vibrations, and collision forces. Therefore, when creating a frame, designers must take into account elements like weight, strength, durability, and crashworthiness.

An important element in the design process is an impact study, which assesses how well the frame performs in various crash scenarios. To assess a frame's crashworthiness, different crash scenarios are simulated, and the behaviour of the frame is assessed. This research aids frame designers in their choice of vehicle frame and suitable material for it to reduce the chance of injury to occupants in the case of an accident and improve vehicle performance.

### 1.1 MATERIAL CONSIDERATION

A variety of criteria, including price, weight, stiffness, strength, longevity, and simplicity of manufacturing, influence the material choice for an automobile's frame. Because of steel's exceptional strength, rigidity, and affordability, vehicle frames have traditionally been composed of this material. Recent trends also include the use of AHS (Advanced High Strength Steel) and HMS (High Manganese Steel). There has also been a movement towards utilising materials like carbon fibre composites, aluminium, and E glass epoxy with the development of lightweight materials to help reduce vehicle frame weight thereby helping the overall vehicle performance and efficiency while maintaining the vehicles structural integrity.

Due to its excellent strength-to-weight ratio and resistance to corrosion, aluminium is also a preferred material for vehicle frames. Luxury and high-performance sports car manufacturing frequently uses it. Even though it is less popular, magnesium offers a strength-to-weight ratio that is higher than that of aluminium and is lighter, making it ideal for applications that demand the greatest possible weight reductions.

Carbon fibre is widely used as of recent in for sports cars and even implemented to build entire frames as it provides the best possible power to weight ratio and has a high rigidity. Carbon fibre is also capable of absorbing large amounts of impact energy thereby making it safer to use for automotive frames. The major drawback of carbon fibre is the cost of the material and machining of carbon fibre with cuts or holes as they tend to weaken that particular area reducing its strength.

### 1.2 LITERATURE REVIEW

M. Meghana, Ch. Shashikanth, M. Pradeep Kumar [1] have chosen and designed a TATA Indica's Bumper and Frame using Pro E as their desired model and carried out a number of static structural analysis using the FEM method with the help of ANSYS software. Their goal is to identify regions of high stress and failure of vehicle frame and bumper and utilise different material choices to find the best suited for the use in a vehicle. They carried out Stress, Strain and Total deformation Analysis of the same model with the following materials:

1. Aluminium Alloy (6061)
2. Stainless Steel
3. Structural Steel
4. Carbon Epoxy

Impact analysis using Static nature is carried out with a load of constant volume (0.0035367m3).

Upon testing each material it is found that carbon epoxy is best suited due to many factors such as being lightweight while having minimum stress, strain as well as least deformation upon impact. Compared to composites aluminium though lightweight has large stresses and deflection due to its greater ductility thereby making it not a favourable option. Both Stainless and Structural steel fare well but again in comparison to the carbon epoxy are too heavy increasing the load on the vehicle and are also difficult to mend upon damage and repair.

This research paper has concluded that the use of carbon composites should be promoted due to their superiority over traditional metals chosen for the purpose of vehicle

Frame and bumper thereby increasing vehicle performance, crash safety and chance of survival in case of impact.

M.Ravi Chandra, S. Sreenivasulu, Syed Altaf Hussain [2] The research paper investigates the structural behaviour and performance of heavy vehicle chassis (TATA 2515EX) made of polymeric composite materials (Carbon, S & E glass epoxy) with different cross-sections (C,I & Box Type) under static loading conditions. The authors developed three cross-sectional geometries using ANSYS software and performed finite element analysis on the models to evaluate their stiffness, strength, and deformation characteristics.

The study found that the box section was the most suitable cross-section for the composite chassis in terms of structural performance. The composite materials proved to be 73-80% lighter in weight than steel frame and also 66-78% stiffer but had a higher natural frequency of 32-54% compared to Steel Frame. However, the research has several gaps, including the lack of experimental validation, no consideration of dynamic loading, and manufacturing processes.

Umang Bharatkumar Ramaiya, Ramesh Babu Vemuluri, SivaPrasad Darla, Edwin Sudhagar P, Ashok B [3]. The research paper includes a study on the impact analysis of a compact sports car's backbone chassis i.e Lotus Europa under various impact scenarios. The structural performance and crashworthiness of the chassis were assessed by the authors using numerical simulations. The researchers created a 3D model of the backbone chassis using Solidworks software and used ANSYS to carry out Static Structural analysis, Modal analysis and Impact analysis of the frame. For the impact analysis, simulations of front, rear, and side impact were carried out with the help of a concrete wall approaching model in a single direction and two velocities were taken into consideration i.e 1st case at 50 Km/h and 2nd case at 100 Km/h for all sides. Additionally two materials were also taken into consideration which are as follows:

1. ASTM A36 (Mild Steel)
2. ASTM B209 – 14 (Aluminium)

Upon analysis and reviewing the results it was found that Mildsteel is preferable over Aluminium as it is less susceptible to failure and has smaller deformations compared to aluminium.

It was also concluded that rear impact in both cases led to chassis failure but had lower deflections than the frontal impact. The maximum deformations and stresses occurred upon frontal impact for the backbone chassis. The analysis

discovered that the compact sports car's backbone chassis had a high level of crashworthiness and could efficiently absorb impact energy.

Nitish Kumar Saini, Rohit Rana, Mohd. Nawaz Hassan, Kartik Goswami [4]. This study is based on a tubular chassis frame designed and modelled using CAD software for the use in a GO-KART. Impact simulation of the frame was achieved with the help of ANSYS software where the frame was subjected to front, side and rear collision using 4 different materials i.e AISI 1018, AISI 1026, AISI 1020 and AISI 4130 (Steel Alloys). This was done to find out which material proved to provide the most protection. The mass of the vehicle along with the driver was taken as 200kg and the speed of impact was set to 60 km/hr in each case while varying the effect of load analysed by 4, 6, 8, 10, 16g and only 3 & 5g for side impact to ensure safety of the driver. The von mises stress was obtained and the factor of safety was calculated for each test along with this the maximum displacement was also obtained.

Upon analysis of each scenario, the results were tabulated and a specific case was deemed a safe design or a failure depending on the factor of safety. It was found that no material could withstand 10g and 16g impact loads on the front and rear end but all the materials could withstand the side impact of 3g and 5g. AISI 4130 proved to be the most suitable for employment in the GO-KART frame as it had the highest safety factors compared to other materials in 4, 6, 8 & 10g loading criterion.

D VARAPRASAD ANJANEYA 2 PENTA SHREENIVASARAO [5]. This research paper uses the existing construction of a VOLVO bus of frameless type which was modelled by using Solidworks software. This type of chassis does not contain conventional cross members between long rails or beams but consists of a tubular structure that takes the body shape of the vehicle and supports all the loads and stresses present and is attached at the bottom to a floor pan like structure. The aim of this research paper is to replace conventional steel alloy material with composite materials such as Carbon Epoxy & E-glass Epoxy and observe their performance in an impact simulation with different speeds of 75, 150 and 300 km/hr and further compares the stress, displacement and strain results to figure out the advantages of their use. COSMOSWORKS, an FEA software, was used to carry out the analysis. Upon testing of each material with the respective impact speeds selected, it was found that the composites, Carbon epoxy and E-glass epoxy had a considerably low amount of displacement and stress values compared to the steel alloy. E-glass epoxy had the lowest displacement and stress proving to be the best suited for use in the frame. The weight of the chassis was also reduced by almost 4 times compared to the conventional design of alloy steel

thereby making the vehicle more fuel and performance efficient while maintaining the safety of vehicle design.

The chassis model was then modified by adding ribs on both the top and bottom side of the frontal section of frame and the simulation was run again with the same parameters. The results showed that this modification further helped reduce the displacement, stress and strain of all materials in all cases by a considerable amount. It was concluded that a combination of material change along with some design optimization provides the best possible design for use with improved structural characteristics.

## 2. DESIGN AND MODELLING

A ladder frame is chosen to be used for impact analysis due to its continuous use in automobiles such as trucks, pickups, buses, jeeps and SUVs. over many years till date. The ladder frame chosen is that of a TOYOTA TACOMA 85' which has been modelled using CATIA V5 (CAD Software).

Frame specification

- Thickness: 4mm
- Section type: Box

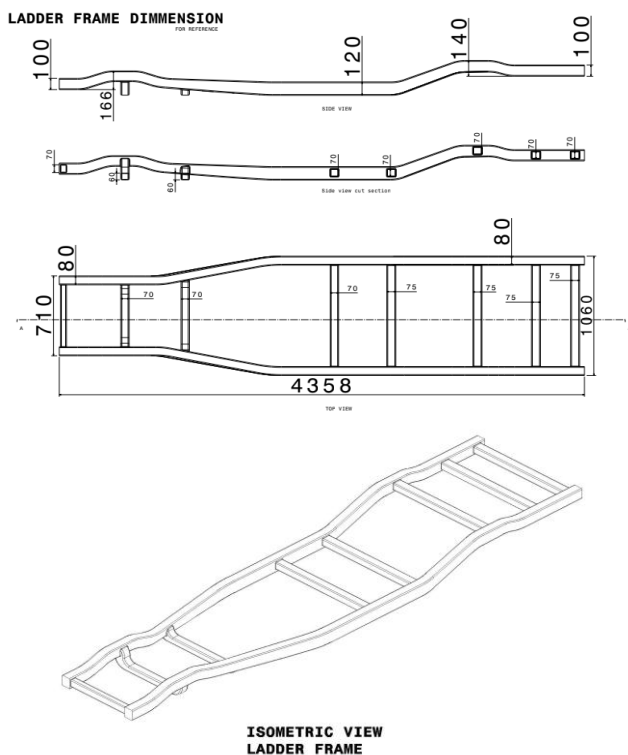

Fig.1 Frame design

## 2.1. IMPACT ANALYSIS OF FRAME

Post design, Front impact analysis is carried out using the FEA Software ANSYS to simulate the event of the frame colliding with a concrete wall as a fixed support. The speed of collision with the wall is considered as 60 Km/hr. The following materials with their properties have been used for the analysis.

MATERIAL	STRUCTURAL STEEL	STAINLESS STEEL	CARBON EPOXY	ALUMINIUM ALLOY	MAGNESIUM ALLOY AZ31B
DENSITY (kg/m <sup>3</sup> )	7850	7750	1600	2770	1775
YOUNG'S MODULUS (Mpa)	2.e+005	1.93e+005	4.5e+004	7.1e+004	44650
TENSILE YIELD STRENGTH (Mpa)	250	207	85	280	155
TENSILE ULTIMATE STRENGTH (Mpa)	460	586	97	310	240

Table -1: Material properties

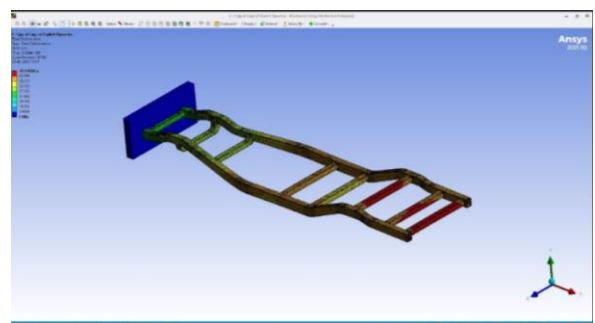

Fig.2 Total Deformation of Structural Steel

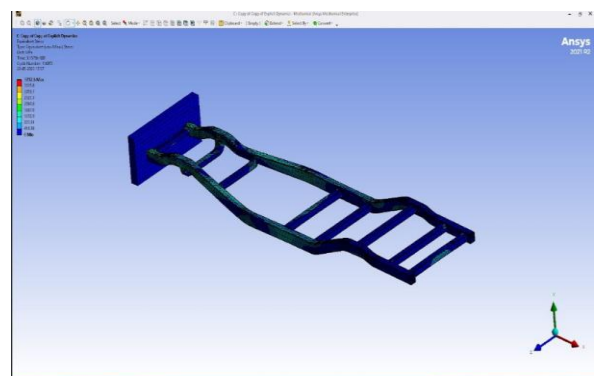

Fig.3 Maximum Stress of Structural Steel

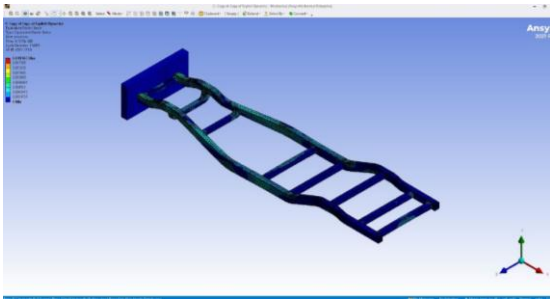

Fig.4 Equivalent Strain of Structural Steel

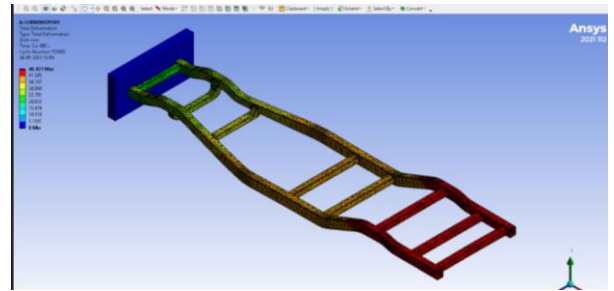

Fig.8 Total Deformation of Carbon Epoxy

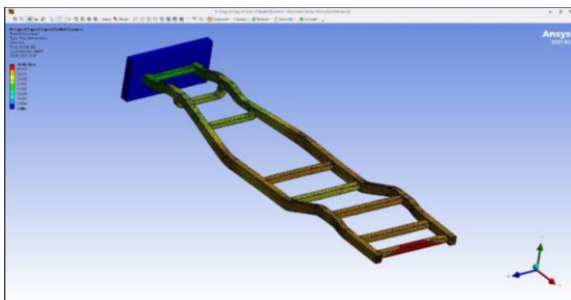

Fig.5 Total Deformation of Stainless Steel

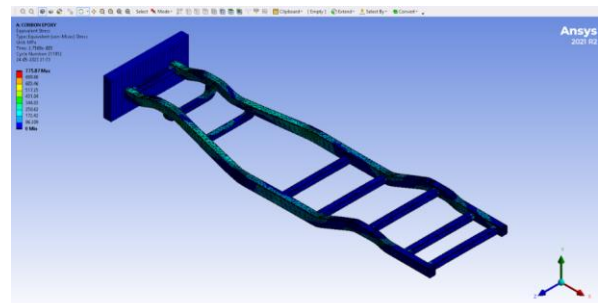

Fig.9 Maximum Stress of Carbon Epoxy

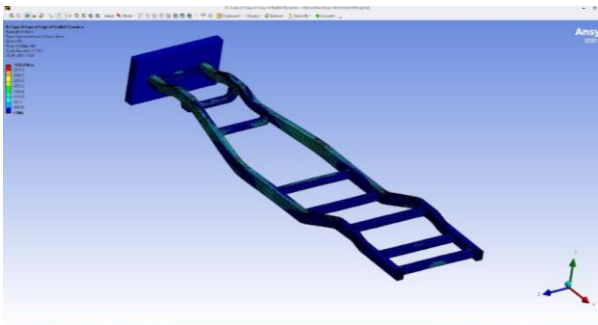

Fig.6 Maximum Stress of Stainless Steel

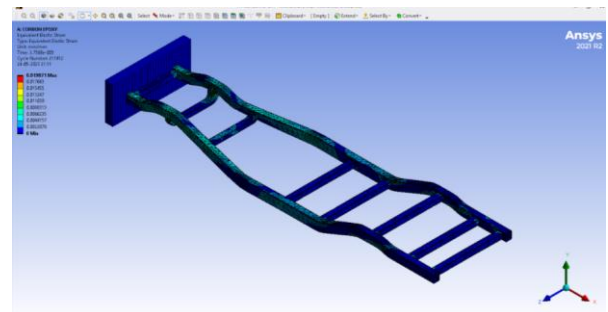

Fig.10 Equivalent Strain of Carbon Epoxy

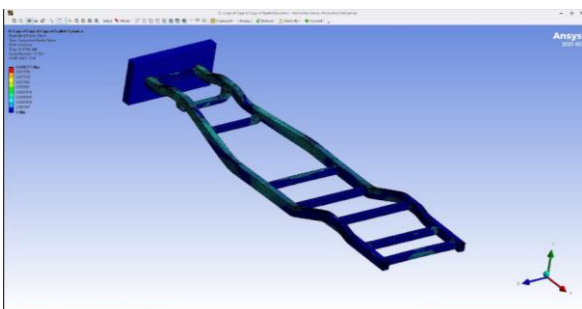

Fig.7 Equivalent Strain of Stainless Steel

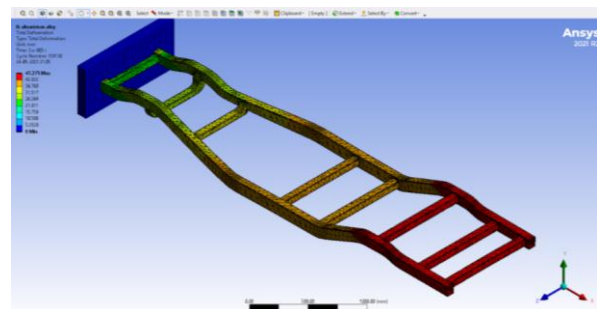

Fig.11 Total Deformation of Aluminium Alloy

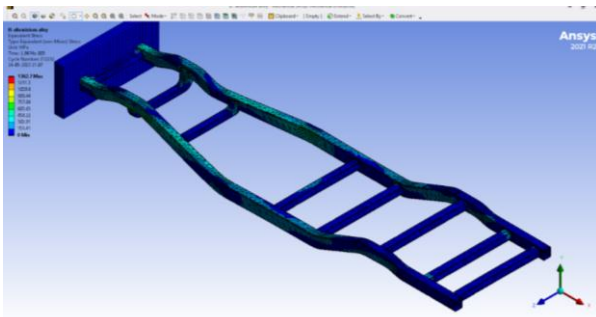

Fig.12 Maximum Stress of Aluminium Alloy

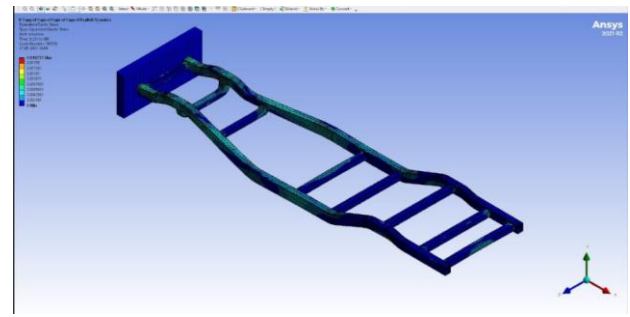

Fig.16 Equivalent Strain of Magnesium Alloy AZ31B

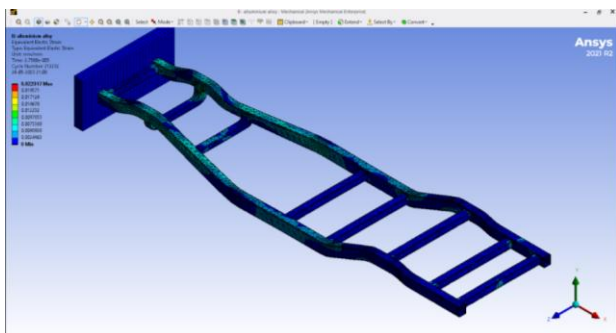

Fig.13 Equivalent Strain of Aluminium Alloy

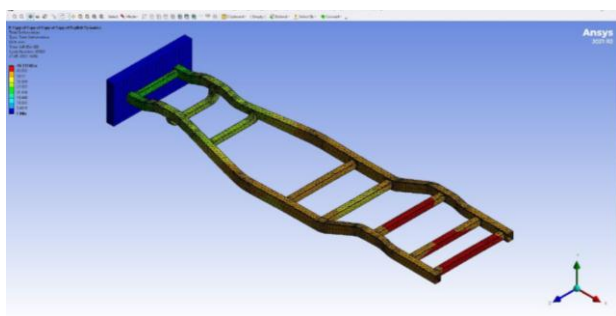

Fig.14 Total Deformation of Magnesium Alloy AZ31B

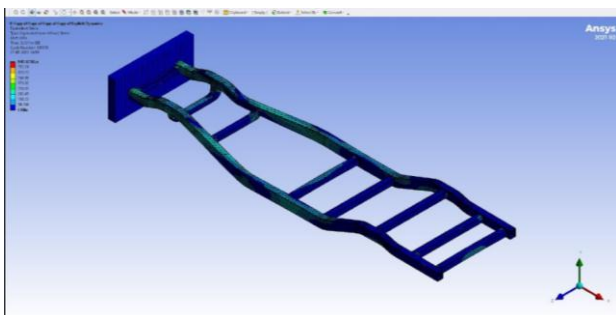

Fig.15 Maximum Stress of Magnesium Alloy AZ31B

## 2.2 RESULTS & DISCUSSION

The following table consists of the values obtained upon impact analysis of the frame for each material.

	Structural Steel	Stainless Steel	Carbon Epoxy	Aluminium Alloy	Magnesium Alloy AZ31B
Total Deformation (mm)	49.144	49.467	46.423	47.275	49.33
Maximum Stress (Mpa)	3752.6	3659.8	775.87	1362.70	847.47
Strain	$1.9563 \times 10^{-2}$	$1.9773 \times 10^{-2}$	$1.9871 \times 10^{-2}$	$2.2000 \times 10^{-2}$	$1.9755 \times 10^{-2}$
Weight (kg)	147.37	145.5	30.038	52.003	33.746

Table -2: Analysis Result

It can be seen that the frame with materials, Carbon Epoxy, Aluminium Alloy and Magnesium Alloy have a considerably low weight as compared to conventional Steel and are around 95-115 kg lighter than them hence allowing the vehicle to be more fuel efficient with a lower curb weight.

The total deformation observed for all the materials are similar and do not have significant differences between them.

Aluminium Alloy has the highest strain value due to its slightly increased ductile nature and has a bigger change in frame length.

The maximum stresses of the materials, Carbon Epoxy, Aluminium Alloy and Magnesium Alloy are also much lower as compared to Structural and Stainless Steel thus making them suitable and a good choice of material for design consideration.

Using these advanced materials would also allow manufacturers to use smaller displacement engines or modern day EV systems with lower rating as they would make the overall weight of the vehicle lighter thereby requiring less effort to propel.

### 3. CONCLUSIONS

This article presents a study of a frontal impact analysis of a ladder frame designed using CATIA V5 software and simulated using FEA ANSYS software.

The impact speed chosen was 60 km/hr and the frame was made to collide with a concrete wall as a fixed support which absorbed no stress and all the stresses were absorbed only by the frame.

The frame material was changed and the total deformation, maximum stress and strain were observed. Structural steel, Stainless steel, Carbon Epoxy, Aluminium Alloy and Magnesium Alloy AZ31B. were chosen.

Carbon epoxy along with Aluminium Alloy and AZ31B were found to be considerably lighter than steel whilst having lower maximum stresses making them a preferable choice over conventional materials.

The difference in deformation faced by all the materials was negligible.

### FUTURE WORK

Further design optimization can be carried out such as varying member thickness, adding additional supports to help reduce stresses induced in frame.

A combination of varying parameters such as use of different materials for specific sections, different beam cross sections, side/rear impact, additional loading with static structural analysis etc. can be incorporated for a better understanding of the materials capabilities.

### REFERENCES

[1] M. Meghana, Ch. Shashikanth, M. Pradeep kumar, "Impact Analysis of Bumper and Car Chassis Frame Due to Frontal Collision for Different Materials", ISSN (ONLINE): 2250-0758, ISSN (PRINT): 2394-6962, Volume-6, Issue-1, January-February-2016.

[2] M.Ravi Chandra, S. Sreenivasulu, Syed Altaf Hussain, "Modeling and Structural analysis of heavy vehicle chassis made of polymeric composite material by three different cross sections", Vol.2, Issue.4, July-Aug. 2012 pp-2594-2600 ISSN: 2249-6645.

[3] U.Bharatkumar Ramaiya, R.Babu Vemuluri, S.Darla, E.Sudhagar P, Ashok B, "Front, rear and side impact analysis of backbone chassis of a compact sports car", doi:10.1088/1757-899X/1123/1/012050.

[4] N.Kumar Saini, R.Rana, Mohd. N.Hassan, K.Goswami, "Design and Impact Analysis of Go-kart Chassis", ISSN 0973-4562 Volume 14, Number 9, 2019.

[5] D.Varaprasad Anjaneya, P. Shreenivasarao, "Design and impact analysis on a frameless chassis construction of volvo bus for different speeds", (ISSN-2349-5162) JETIR November 2018, Volume 5, Issue 11.