

Structural performance of prefabricated cage reinforced concrete composite structures

Beema Subair¹, Sumayyath M.M²

¹Student, Dept. of Civil Engineering, ICET Mulavoor, Kerala, India

²Asst.Professor, Dept. of Civil Engineering, ICET Mulavoor, Kerala, India

Abstract -In this study, reinforced concrete has been replaced with a prefabricated reinforcing cage system for beam, in terms of their ultimate capacities, flexural performances, ductility behaviour, and load v/s displacement curves. Prefabricated reinforced beams with varied cage thicknesses are compared to conventional RCC beams. Using varied stirrup opening shapes, the shear confinement and spiral confinement effects from the chosen thickness were evaluated and compared to the conventional RCC model. The models are done by using ANSYS 2022 Software, and results are compared to conventional RCC beam. The results show that a 6mm cage thickness is better for beams. For beams, the performance of models like the diamond and elliptical models is improved by 35.3% and 2.7%, respectively. With a 13.22% load increase. The results of this study indicate that prefabricated cages for beam with various cutting shapes can improve performance.

Key Words: prefabricated cage system (pcs), cage thickness 3mm(T3), cage thickness 4mm(T4), cage thickness 5mm(T5), cage thickness 6mm(T6), Reinforced cement concrete (RCC)

1. INTRODUCTION

One of the most popular composite systems worldwide is reinforced concrete. The effectiveness of individual reinforced concrete system components has an impact on the effectiveness of the system as a whole. To enhance the performance of structural elements, research has been done on a variety of technologies that could replace the traditional reinforced concrete system. The Prefabricated Cage System (PCS) is one of these studies. his approach is based on the idea of using perforated steel pipes or plates in place of the traditional concrete reinforcing. Work on PCS-reinforced columns using standard and high strength concrete the studies revealed that the columns reinforced with PCS exhibited elastic behaviour similar to that of conventionally reinforced concrete systems, but they also displayed more ductile behaviour, had a higher energy absorption capacity, and increased the strength and displacement capacity of the column. Furthermore, it was discovered that the PCS's confinement effect kept the steel from buckling.

Although the production of PCS reinforcement can be more expensive than conventional reinforcement for a particular structural member, PCS can be thought of as more

inexpensive from an engineering standpoint than traditional reinforcing systems. Compared to traditional reinforcement systems, PCS can be thought of as being more cost-effective. The fabrication of PCS reinforcement uses far less material than traditional reinforcing systems and takes much less time. Additionally, fabricating PCS might considerably cut labour costs. Reducing labour costs, which account for a significant portion of construction costs, lowers overall construction costs. the use of PCS reinforcement in columns provides a considerable saving from construction costs and time.

Work on reinforced concrete beams with continuous rectangular spiral reinforcement in this, the Experimental research is done on the behaviour of shear-critical reinforced concrete beams with rectangular cross sections and continuous rectangular spiral reinforcement as transverse reinforcement. Additionally, a sophisticated rectangular spiral reinforcement with vertical links that are oriented in favour of shear is presented and put to the test. There are eight beams in the experimental programme. The results of the tests clearly show that the adoption of rectangular spiral reinforcement improved the shear performance and bearing capacity of the tested beam.

In this study, prefabricated reinforced beams with various thicknesses are compared to conventional RCC beams and columns in terms of their ultimate capacities, flexural performances, spiral confinement effect, ductility behaviour, load v/s displacement curves, and opening shapes of the stirrups with various breadth. The models are done by using ANSYS 2022 Software, and results are compared to conventional RCC beam, the diamond shape performs significantly better than the conventional RCC.

1.1 PCS system and confinement effect

One of the most common composite systems utilized globally is reinforced concrete systems. The effectiveness of the reinforced concrete system as a whole is influenced by the effectiveness of its individual components. To enhance the performance of structural elements, research has been done on a variety of technologies that could replace the traditional reinforced concrete system. in this the load capacities of reinforced beam and column, to enhance the structural performance of beam and column prior to the conventional system. For this the thickness is varied from 3

to 6 among the better thickness one the opening shape is varied to elliptical, triangle, diamond.

It is well acknowledged that using continuous spiral reinforcement in reinforced concrete (RC) elements with cyclic cross-sections can significantly increase the concrete's strength and ductility, and consequently the structural element's overall seismic reaction and capacity. This research examines the structural performance of beams using single spiral confinements and double spiral confinements. The confinement effect is often related to the structural parts' ability to sustain loads.

1.2 Objectives and scopes

The main objective of the study is the flexural bending performance of the prefabricated cage structure in beam and finding the optimum thickness, weight and strength performance in comparison with conventional reinforcement as per IS code. From the optimum thickness performing the other parametric study like, effect of the confinement shape (elliptical, triangle, diamond), Effect of the spiral confinement (double, single), and the output results like ultimate deflection, ultimate load, percentage of improvement in strength are evaluate and compared.

In the present study new reinforcement system called prefabricated cage structure is introduce in beam. The study will give an idea about the performance of the prefabricated cage structure in beam in place of conventionally reinforced concrete, The models are done by Nonlinear static analysis in Workbench of Ansys (2022).

2. FLEXURAL BENDING PERFORMANCE OF THE PCS IN BEAM

Analysis on prefabricated cage structure in beam and finding the flexural performance. For this selecting the optimum thickness of the cage from T3, T4, T5, T6 by comparing the result with the conventional RCC beam. For all models, the prefabricated beam's dimensions are 100x180x1000mm and in steel tube the cage thickness is varied from 3 to 6 mm the steel tube dimensions are 80x160x3mm(T3), 80 x 160x4mm (T4),80x160x5mm (T5), 80x160x6mm (T6). Material properties of the beams are Young's modulus 2×10^5 Mpa, Poisson's ratio 0.15, Grade M25, Density 2400 kg/m³ and material properties of steel tube is Young's modulus 2×10^5 Mpa, Poisson's ratio 0.3, Density 7850 kg/m³.

2.1 Modelling

Conventional RCC beam and Prefabricated cages for beam with varying thickness are modelled in ANSYS software. Conventional RCC is designed as per IS code having main bar 12 mm diameter and 8 mm diameter stirrups are used with a spacing of 100 mm c/c. Prefabricated thickness varied like T3, T4, T5, T6. Modelling is done by using element type

BEAM 188 and the element type of concrete SOLID 186. Fig-1 shows the model of pcs beam.

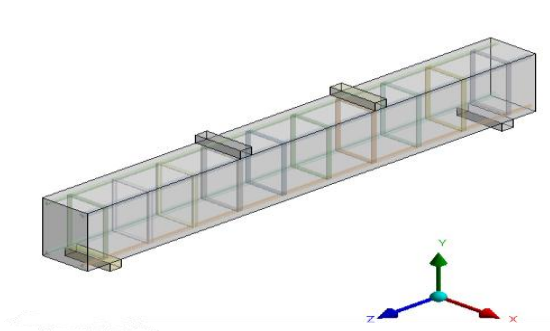

Fig -1: Model of prefabricated cage for beam

2.1.1 Meshing and loading

Prefabricated cage for beam is modelled using hexahedral which is a 20-noded mesh. Program controlled coarse mesh is adopted for meshing the beams. The mesh size 40 mm. Load is applied as displacement of 10mm according to displacement convergence method. The loading is applied 300 mm away from both the supports.

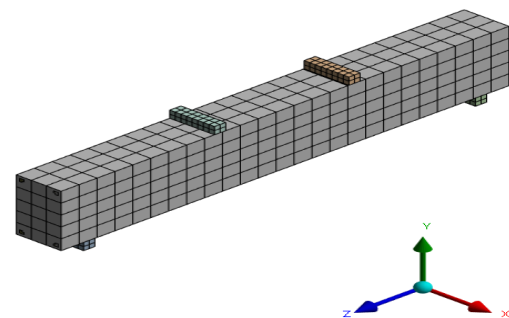

Fig -2: meshing of prefabricated cage for beam

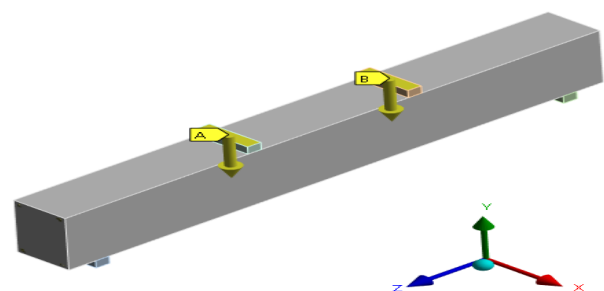
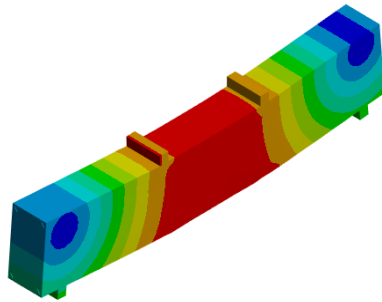

Fig -3: Loading of prefabricated cage for beam

2.2 Analysis

Analysis is carried out to study the flexural performance of prefabricated beam with different prefabricated cage

A: conventional
Total Deformation
Type: Total Deformation
Unit: mm
Time: 0.7 s
25-04-2023 11:48



Deformation of conventional RCC

E: T6
Total Deformation
Type: Total Deformation
Unit: mm
Time: 0.7 s
23-05-2023 11:06

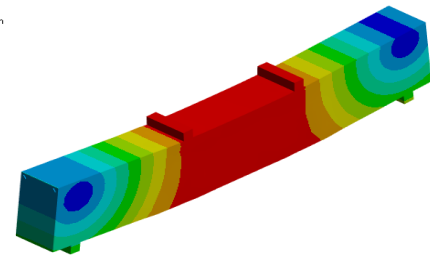

Deformation of T6 80x160x6mm

Fig -3: Deformation diagram

B: T3
Total Deformation
Type: Total Deformation
Unit: mm
Time: 0.7 s
25-04-2023 11:49

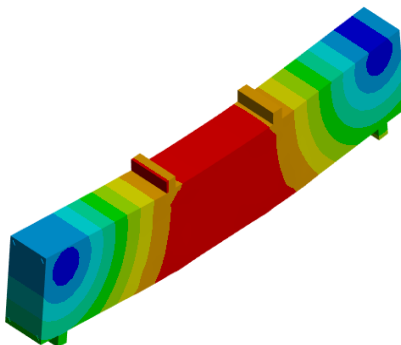

Deformation of T3 80x160x3mm

C: T4
Total Deformation
Type: Total Deformation
Unit: mm
Time: 0.7 s
25-04-2023 11:50

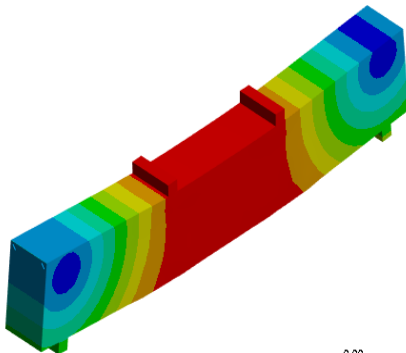

Deformation of T4 80x160x4mm

D: T5
Total Deformation
Type: Total Deformation
Unit: mm
Time: 0.7 s
25-04-2023 11:52

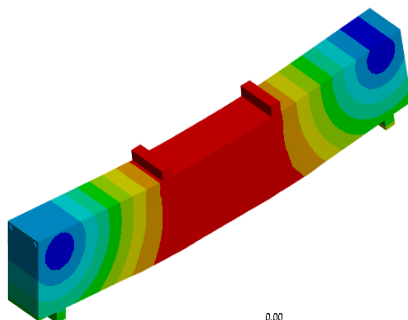

Deformation of T5 80x160x5mm

2.3 Result and discussion

The result obtained from the Nonlinear static structural analysis prefabricated cage like T3 80x160x3mm, T4 80x160x4mm, T5 80x160x5mm, T6 80x160x6mm are compared with conventional RCC. For that load deformation curve is taken for each model.

Table -1: Properties of prefabricated cage for beams

Model	Stirrups				Longitudinal reinforcement		
	Spacing (mm)	Area	t	l	t	l	b
T3	100	30	3	10	3	10	10
T4	100	40	4	10	4	10	10
T5	100	50	5	10	5	10	10
T6	100	60	6	10	6	10	10
Con - RCC	8mm dia			12 mm dia			

Note: All units are in millimetre.

Table 2 shows the reinforcement details of the models. Ast-area of tension steel, Asc-area of compression steel. they are given in the table from T4 to T6 their Ast and Asc are 128,150,168 mm² respectively which is higher than the conventional RCC beam 113.04 mm². T4, T5, T6 satisfies the minimum and the maximum As requirements.

Table -2: Reinforcement details of models

beam	Equivalent area of -4 bar	Ast (mm ²)	Asc (mm ²)	% of steel	fck (N/m ²)	b (mm)	d (mm)	Steel Fy (Mpa)	min As As = 0.85 bd/fy (mm ²)	Max As As= 0.04 bD (mm ²)
				Ast/bd x 100						
T3	204	102	102	0.5666	25	100	180	250	61.2	720
T4	256	128	128	0.7111	25	100	180	250	61.2	720
T5	300	150	150	0.8333	25	100	180	250	61.2	720
T6	336	168	168	0.9333	25	100	180	250	61.2	720
Con - RCC	452.16	226.08	226.08	1.256	25	100	180	415	36.86	720

Table -3: Comparison of results

Result				Longitudinal reinforcement		
Beam	Def (mm)	Load (kN)	%	Area - 1 bar (mm ²)	Area-4 bar (mm ²)	Main bar wgt (kg)
CON-RCC	18.23	49.98		113.04	452.16	3.6
T3	23.04	31.34	-37.3	51	204	1.6
T4	25.22	34.90	-30.2	64	256	2.0
T5	24.51	37.89	-24.2	75	300	2.4
T6	31.03	54.22	8.5	84	336	2.6

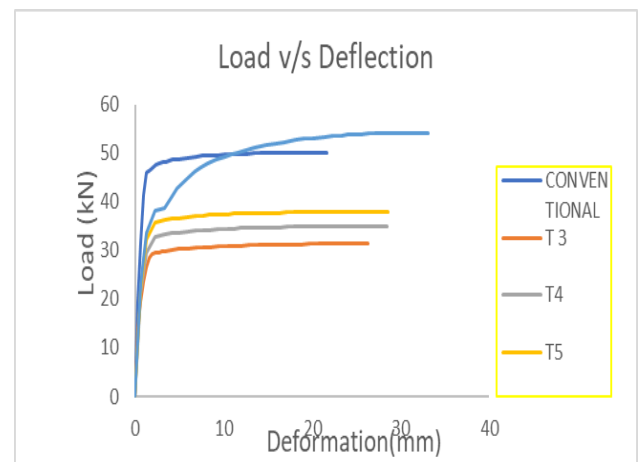

Chart -1: Load deflection comparison

From the study finding out the optimum thickness as T6. The thickness varied from 3 to 6, among this T6 shows better performance compared with conventional RCC. Since the maximum load and deflection was obtained for the specimen T6 80x160x6mm the optimum value for D is 31.03 mm and the maximum load carrying capacity is 54.22 kN. From the study of implementing prefabricated cage for beams instead of conventional RCC beam, it was found that, Load carrying capacity was increased by 8.5%. T6 performs better than RCC, when comparing with its area of steel reinforcement and its weight. The area of longitudinal steel reinforcement is 452.16 for conventional RCC beam and for T6 it is 336 mm². Hence the steel reinforcement is lesser in T 6 and shows better performance. The weight of main bar for RCC

Note: a* – area of stirrups, t*- thickness, l*-length, Def*- deformation, b*-breadth. All the dimensions are in millimetres

The load and deflection obtained are compared. The Table 6.3 shows the comparison of results

beam is 3.6 kg, for T6 is 2.6 kg, the weight is also lesser when it compared with the RCC.

3. SHEAR CONFINEMENT EFFECT OF THE PCS IN BEAM

shear confinement effect of prefabricated Cage for beam, taking the optimum thickness as 6 mm from the above result. And finding the shear confinement effect using the pattern elliptical, triangle, diamond, double spiral (DS), single spiral (SS), then finding the better performed one in comparison with conventional RCC beam. The different models used are elliptical 80x160x6mm, triangle 80x160x6mm, diamond 80x160x6mm, DS 80x160x6mm, SS 80x160x6mm. For single spiral selecting 4 models with varying stirrup width (20,30,40,50 mm)

3.1 Modelling

Prefabricated beam cage is modelled in ANSYS software with different specimen dimensions like elliptical 80x160x6mm, triangle 80x160x6mm, diamond 80x160x6mm, DS 80x160x6mm, SS 80x160x6mm. Single spiral 80x160x6mm with varying breadth of the confinement such as SS10x20x6 mm, SS10x30x6 mm, SS 10x40x6, SS10x50x6 mm. 8 beams are modelled.

3.1.1 Meshing and loading

Prefabricated cage for beam is modelled using hexahedral which is a 20-noded mesh. Programme controlled coarse mesh is adopted for meshing the beams. The mesh size 40 mm. Load is applied as displacement of 10mm according to displacement convergence method. The loading is applied 300 mm away from the support

3.2 Analysis

Analysis is carried out to study the flexural performance and shear confinement effect of prefabricated beam with different cutting shape. Nonlinear static structural analysis is carried out in ANSYS software. Deformation and load carrying capacity is studied. The deformation diagrams are shown in Fig 4

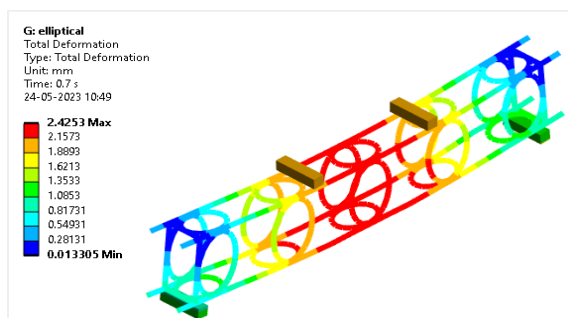

elliptical 80x160x6mm

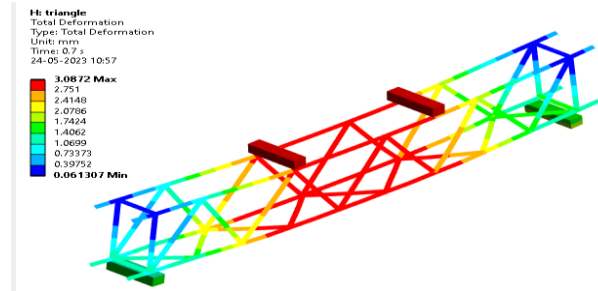

triangle 80x160x6mm

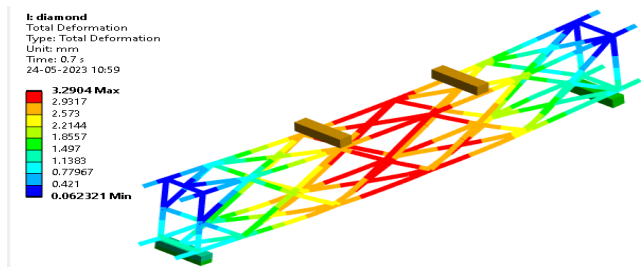

diamond 80x160x6mm

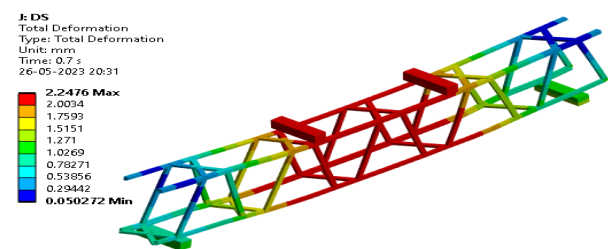

DS 80x160x6mm

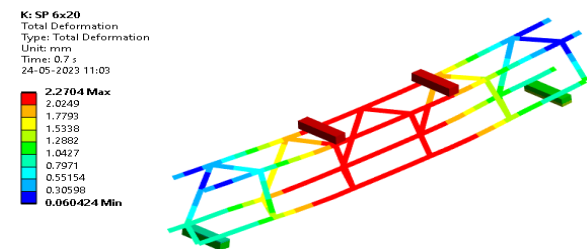

SS 80x160x6mm with Stirrup width 20 mm

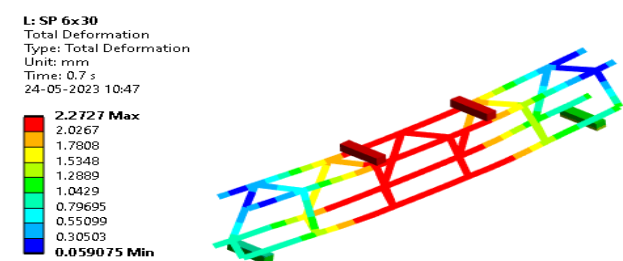

SS 80x160x6mm with Stirrup width 30 mm

M: SP 6x40
Total Deformation
Type: Total Deformation
Unit: mm
Time: 0.7 s
24-05-2023 10:46

2.2616 Max
2.0164
1.7712
1.526
1.2807
1.0355
0.79031
0.54509
0.29988
0.054661 Min

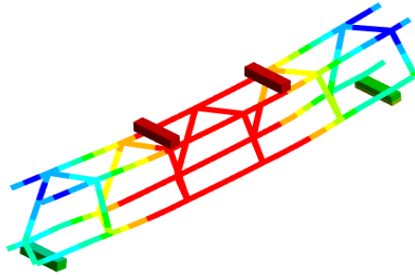

SS 80x160x6mm with SS 80x160x6mm with

N: SP 6x50
Total Deformation
Type: Total Deformation
Unit: mm
Time: 0.7 s
24-05-2023 11:19

2.2675 Max
2.0215
1.7756
1.5297
1.2897
1.0378
0.79183
0.54588
0.29994
0.053993 Min

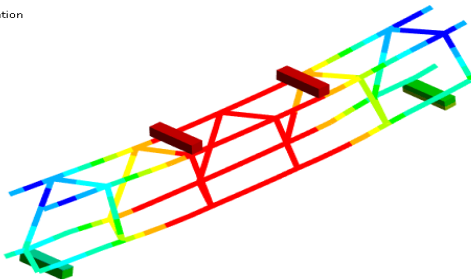

SS 80x160x6mm with Stirrup width 50 mm

A: conventional
Total Deformation
Type: Total Deformation
Unit: mm
Time: 0.7 s
24-05-2023 11:39

2.3793 Max
2.1202
1.8611
1.6021
1.345
1.0839
0.82487
0.56581
0.30674
0.047681 Min

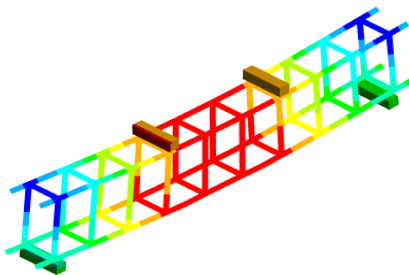

Conventional RCC beam

Fig -4: Deformation diagram

3.3 Result and discussion

The result obtained from the Nonlinear static structural analysis prefabricated cage like elliptical 80x160x6mm, triangle 80x160x6mm, diamond 80x160x6mm, DS 80x160x6mm, SS 80x160x6mm. Single spiral 80x160x6mm with varying breadth of the confinement such as SS10x20x6 mm, SS10x30x6 mm, SS10x40x6, SS10x50x6 are compared with conventional RCC in order to find which cutting shape has more confinement effect. For that load deformation curve is taken for each model. The load and deflection obtained are compared with conventional RCC beam. According to the result obtained from objective 1 the optimum thickness is taken (T6). The Table 6.3 shows the comparison of results and Fig.6.5 shows comparison of load deflection curve.

Table -4: Properties of prefabricated cage for beams

Stirrup			Model	Longitudinal reinforcement				
Spacing (mm)	a	t	Beam	t	l	b	Area - 4 bar	Main bar wgt
8 mm			Con-RCC	12 mm			452.1	3.6
100	60	6	Elliptical	6	10	10	336	2.6
100	60	6	Triangle	6	10	10	336	2.6
100	60	6	Diamond	6	10	10	336	2.6
100	60	6	Double spiral	6	10	10	336	2.6
100	120	6	SS 6x20	6	10	10	336	2.6
100	180	6	SS 6x30	6	10	10	336	2.6
100	240	6	SS 6x40	6	10	10	336	2.6
100	300	6	SS 6x50	6	10	10	336	2.6

Table -5: Comparison of results

Beam	Def (mm)	Load (kN)	%
Con-RCC	18.238	49.989	
Elliptical	31.23	51.316	2.7
Triangle	15.287	40.339	-19.3
Diamond	22.736	67.631	35.3
Double spiral	29.253	45.034	-9.9
SS 6x20	29.28	45.141	-9.7
SS 6x30	30.96	44.746	-10.5
SS 6x40	31.056	44.628	-10.7
SS 6x50	32.724	44.467	-11.0

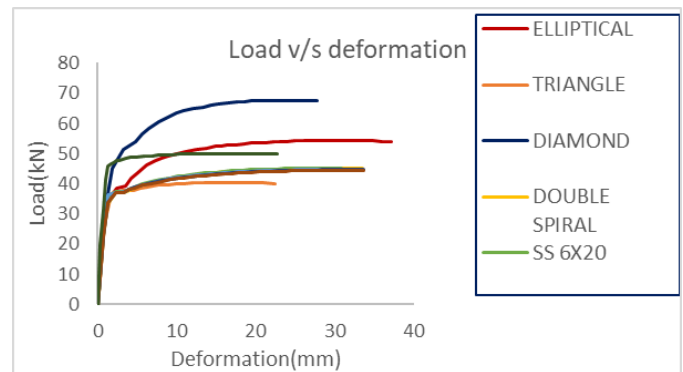

Chart -1: Load deflection comparison

From the effect of different type of confinement study using different cutting shape on prefabricated cage by using optimum thickness, it was found that, Elliptical, triangle, diamond among these three-shape diamond gives the effective performance with 35.3 % load increase in the confinement study. Load carrying capacity was increased by 35.3 % for diamond cutting shape compared with conventional RCC. Load carrying capacity was increased by 2.7% for elliptical cutting shape. Spiral confinement study of double and Single spiral confinement, load capacity is slightly decrease from the conventional RCC beam. For DS and SS deformation capacity is increased so that the ductility performance increases. Ultimate deflection capacity increased in the spiral confinement when the breadth of the confinement increases to 20,30,40,50 mm. Deflection capacity of 79.42% increases for single spiral 60x50 compared with conventional RCC beam.

4. CONCLUSIONS

Prefabricated cage for beams with different cage thickness and different cutting shape are modelled and analysed. The comparison of prefabricated cage for beams are studied. Shear confinement effect of different cutting shapes are analysed by ANSYS software and obtain the load v/s deformation behaviour.

- Compared to the standard RCC beam, the prefabricated cage for beam with a cage thickness of 6 mm demonstrates greater load carrying capacity. Since the specimen T6 80x160x6mm achieved the ultimate load and deflection. The ideal deflection value is 31.03 mm, and the ideal load is 54.22 kN.
- For a conventional RCC beam, the longitudinal steel reinforcement area is 452.16 mm², while for a T6 beam, it is 336 mm². As a result, T6 has less steel reinforcement and performs better.
- Elliptical, triangular, and diamond among these three-shape diamond delivers the effective performance with a 35.3% load increase in the confinement study, according to the results of the confinement study utilizing the best thickness and various cutting shapes on a prefabricated cage.
- The load capacity of double and single spiral confinements is slightly lower than that of a conventional RCC beam. Deformation capacity is improved for DS and SS, improving ductility performance. When compared to a conventional RCC beam, the single spiral 60x50's deflection capacity rose by 79.42%.
- According to the study, the diamond model and T6 prefabricated cage perform better than the traditional RCC in terms of flexural strength.

REFERENCES

- [1] Abdulkadir Gulec, M. Metin Kose b, M. Tolga "An analysis of the usability of prefabricated cage-reinforced composite beams with self-compacting and lightweight concrete under flexural loads". (2020)
- [2] Abdulkadir Gulec, Mehmet Metin Kose, Mehmet Tolga Gogus "Experimental investigation of flexural performance of T-section prefabricated cage reinforced beams with self-compacting concrete" (2021)
- [3] Chris G. Karayannis, Constantin E. Chalioris "Shear tests of reinforced concrete beams with continuous rectangular spiral reinforcement"(2013)
- [4] Mahdi Momeni, Johan Relefors Abubakar Khatry, Lars Pettersson, Alessandro Papadopoulos, Thomas Nolte "Automated fabrication of reinforcement cages using a robotized production cell" (2013)
- [5] Yu-Chen Ou, Jhe-Yan Li, Hwasung Roh c, "Shear strength of reinforced concrete columns with five-spiral reinforcement" (2021)
- [6] Murtada S. Mohsin, Nameer A. Alwash, Mohammed M. Kadhum "Structural behavior of reinforced concrete beams with out of plane part" (2021)
- [7] Chithra Rethnasamy a, Thenmozhi Rajagopal b, Hareesh Muthuraj "Bending behavior, deformability and strength analysis of Prefabricated Cage Reinforced Composite beams" (2013)
- [8] Seung-Hyeon Hwang, Keun-Hyeok Yang, Yong-Soo Choi, Seung-Jun Kwon d "Axial and flexural performances of columns restored after severe damage "(2021)
- [9] Song Xia a,b , Xinyi Wei , Chang He , Faxing Ding , Weizhen Zhang d , Jiaye Wu e , Sen Yang "Performance of stirrup-confined concrete-filled steel tubular stub columns under axial loading: A further investigation" (2022)
- [10] Worakarn Anuntasena, Akhrawat Lenwari, Thaksin Thepchatrri "Axial compression behavior of concrete-encased cellular steel columns" 2020