

# A Design Strategy Based On Optimization Techniques For Compressor Support Bracket And Vibration Analysis By Using FFT

Pareshkumar Nawanathsing Rajput<sup>1</sup>, Amol B. Gaikwad<sup>2</sup>, Kharad B.N.<sup>3</sup>

<sup>1</sup>Sholar, Dept of Mechanical Engg, Vishwabharti Academy's College of Engineering, Ahmednagar, Maharashtra, India

<sup>2</sup>Asst. Prof. Dept of Mechanical Engg, Dr. D.Y.Patil School of Engineering, Pune, Maharashtra, India

<sup>3</sup>Asst. Prof. Dept of Mechanical Engg, Vishwabharti Academy's College of Engineering, Ahmednagar, Maharashtra, India

\*\*\*

## Abstract:

The objective of this project is to analyze and optimize the bracket's weight by selecting a different material.

Reducing the weight of the bracket not only helps decrease raw material costs but also improves overall efficiency, although the impact may be minimal. This study also aims to identify the factors that contribute to bracket failure and assess the effects of optimization through various analyses, including vibration analysis, deformation analysis, and Von Mises stress analysis.

The project involves the design of an AC mounting bracket, which is created using modeling software and analyzed using ANSYS Software. The design of experiments (DOE) technique is employed to develop a glass fiber reinforced plastic (GFRP) bracket. The GFRP bracket is then subjected to analysis using ANSYS to evaluate its performance.

The project reports a weight reduction of 66.67% achieved in the redesigned bracket. Additionally, the frequencies of the steel and composite brackets are to be checked. This refers to assessing the natural frequencies or resonant frequencies of the brackets to ensure they fall within acceptable ranges. It is crucial to avoid resonances that could lead to excessive vibration or failure.

The project suggests that the GFRP bracket offers advantages over the steel bracket in terms of vibration. The vibration levels of the GFRP material are measured by connecting a probe to monitor acceleration and displacement in relation to the motor's RPM. Furthermore, the weight reduction achieved through the GFRP compressor mounting bracket leads to reduced noise compared to the steel bracket.

**Keywords:** - Compressor mounting bracket, ANSYS, Design of Experiments

## 1.INTRODUCTION:

The compressor is a crucial component in the automotive air conditioning system and is subjected to unbalanced forces generated by the engine and compressor itself, resulting in structural vibrations. To mitigate these

vibratory forces, a compressor mounting bracket is employed to support the compressor.



Fig.1.1:- Compressor Mounting Bracket

Optimization is a fundamental aspect of problem-solving in a range of disciplines, including engineering and economics. The process of decision-making involves making choices among different options, and the goal is to make the optimal decision. The evaluation of these alternatives is typically determined by an objective function or performance index, which measures their quality. Optimization theory and methods are concerned with identifying the best possible alternative based on the given objective function.

## 1.1 Composite Material

### 1.1.1 Polymer Matrix Composite

Resins like epoxies and polyesters alone do not possess high mechanical properties, limiting their use in structural manufacturing. However, when combined with reinforcement in the form of fibers, the resulting composite exhibits enhanced tensile and compressive properties compared to the solid resin. These properties may not be immediately evident in the individual components.

Fibers in the composite primarily contribute to tensile strength along their length. When the fibers are integrated with the resin, the load applied to the composite is distributed across the resin, effectively spreading the load among the individual fibers. The combination of resin and

reinforcing fiber in a polymer matrix composite yields exceptional properties, improving the overall performance of the material.

**The properties of the composite are influenced by several factors:**

Individual properties of the fiber and resin: The mechanical properties of the composite depend on the inherent characteristics of the fibers and the resin used.

Mixture ratio of fiber and resin: The proportion of fibers to resin in the composite affects its overall properties. Varying the ratio can lead to different levels of reinforcement and mechanical performance.

Geometry and fiber orientation: The arrangement and orientation of the fibers within the composite play a significant role in determining its mechanical behavior. Factors such as fiber alignment and stacking sequence impact the overall strength and stiffness of the composite. By considering these factors, the properties of the composite can be tailored to meet specific requirements, resulting in a material that combines the desirable characteristics of both the resin matrix and the reinforcing fiber.

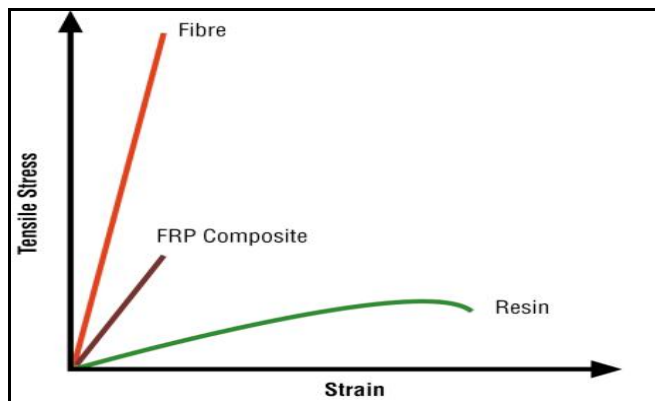

Fig.1.2:- Tensile modulus of fiber and resin composite

**2. PROBLEM DEFINITION**

The existing design of the compressor mounting bracket may not be fully optimized in terms of performance, cost-effectiveness, and ease of manufacturing. There is a requirement to enhance the design and optimize the bracket to improve its overall efficiency, reliability, and production feasibility.

**2.1 Objectives Of The Project**

The current work aims to achieve the following key objectives:

- Designing the compressor mounting bracket for automotive air conditioning applications using conventional materials.
- Designing the compressor mounting bracket using GFRP (Glass Fiber Reinforced Plastic) material and conducting various experimental analyses on the composite material.
- Performing vibration and noise analysis, as well as optimization using Finite Element Analysis (FEA) techniques on the existing material design.
- Comparing and selecting the most suitable alternative based on the results obtained from stress analysis.
- Manufacturing and testing the chosen alternative, and comparing the experimental results with the FEA and theoretical analyses.

**3. ANALYTICAL CALCULATIONS OF COMPRESSOR MOUNTING BRACKET**

Bracket's width, which can be either narrower or wider than the compressor's width. This configuration results in the bracket having a closed L shape, with dimensions of 446 mm in length and 150 mm in width.

**The following stresses need to be evaluated:**

Shear stress.  
Direct and bending stress.  
A weight of 15 kg is applied precisely on the bracket. The material selected for manufacturing the bracket is steel.

The component installed on the automobile experiences forces acting independently in all three directions, equivalent to 3 times the acceleration due to gravity (3g). These forces are applied to the compressor.

The area of the plate under the compressor measures 450 mm by 150 mm.  
 $A = 450 \times 150 = 67500 \text{ mm}^2$

$$\text{Load acting} = 15\text{kg} \times 3 \times \text{gravitational acce}$$

$$\text{Load acting} = 15 \times 3 \times 9.81$$

$$\text{Load acting } L = 441 \text{ N}$$

$$\text{Direct Stress} = \frac{441}{67500}$$

$$\text{Pressure} = 0.006539 \text{ MPa}$$

#### 4. FINITE ELEMENT ANALYSIS

Various areas of interest commonly encountered in engineering include structural analysis, heat transfer, fluid flow, mass transport, and electromagnetic potential. Addressing these problems typically involves solving boundary value problems associated with partial differential equations. By formulating the problems using the finite element method, a system of algebraic equations is obtained as the solution.

##### 4.1 FEA Results

###### 4.1.1. Steel Bracket

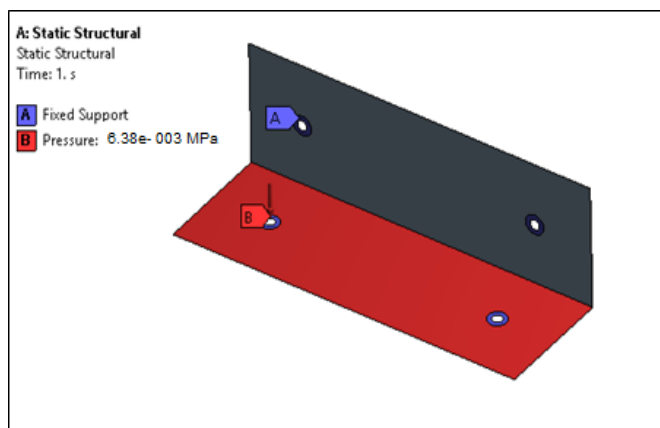

Fig.4.1:- Boundary loading condition for steel bracket. Figure 4.1 displays the boundary conditions and loading for the static analysis. The figure illustrates the application of a total pressure of 0.006539 MPa on the surface, simulating a 441 N load resulting from a 3 gram acceleration of the compressor assembly towards the base. Additionally, fixed boundary conditions are applied to all four bolt holes to simulate the bolted connection between the bracket and the chassis. The bracket itself has a mass of approximately 3.9 kg.

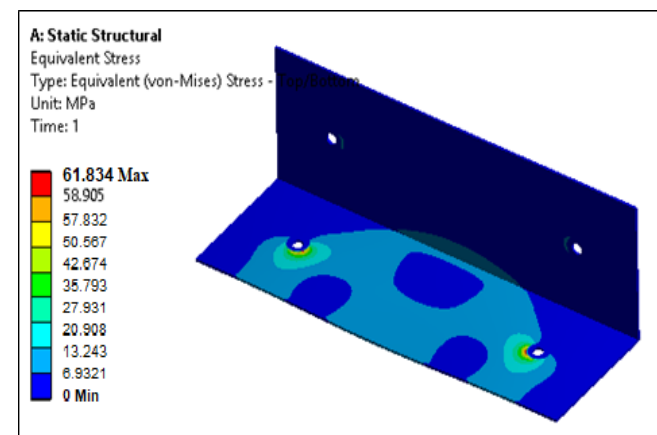

Fig.4.2:- von Mises stress of steel for Compressor Mounting Bracket

The Von Mises stress plot reveals that the maximum stress experienced by the steel bracket of the compressor, resulting from the 3 gram loading, is 61.834 MPa. This value falls comfortably within the acceptance criterion of 185 MPa. Therefore, based on the static Finite Element Analysis (FEA) results, it can be concluded that the steel design is deemed safe.

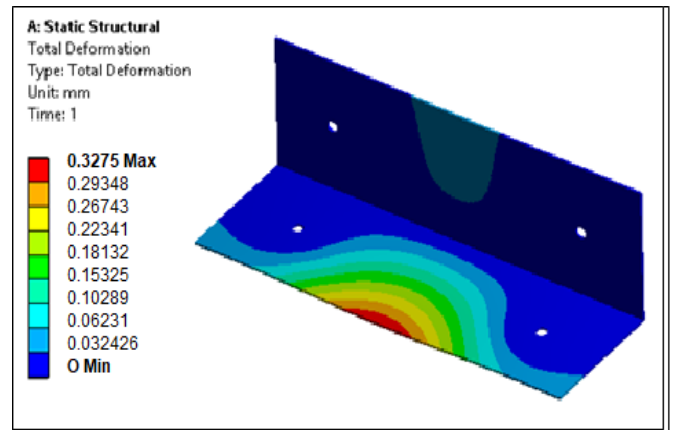

Fig.4.3:- Total deformation of steel Compressor mounting Bracket.

The total deformation of the steel bracket, as shown in Figure 4.3, indicates a maximum deformation of 0.33 mm. This deformation is considered negligible, especially when taking into account that only 1/3 of the actual load is continuously applied to the bracket under real conditions.

##### 4.2 GFRP bracket design.

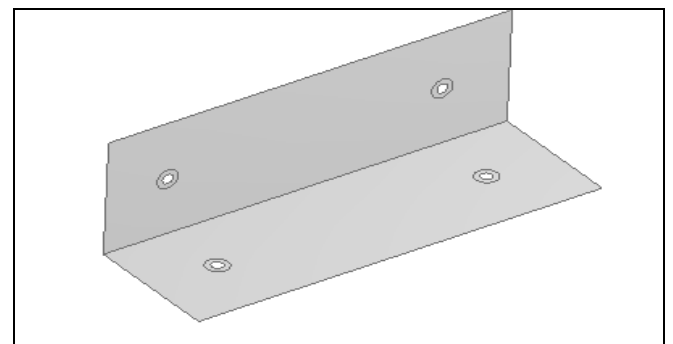

Fig.4.4:- Geometry of GFRP compressor support bracket. The surface of the model is extracted to generate the compressor support bracket using GFRP (Glass Fiber Reinforced Plastic) material. The bracket will be assigned appropriate meshing size and thickness, considering the ply material properties, within the Advance Composite Pre-processor of ANSYS.

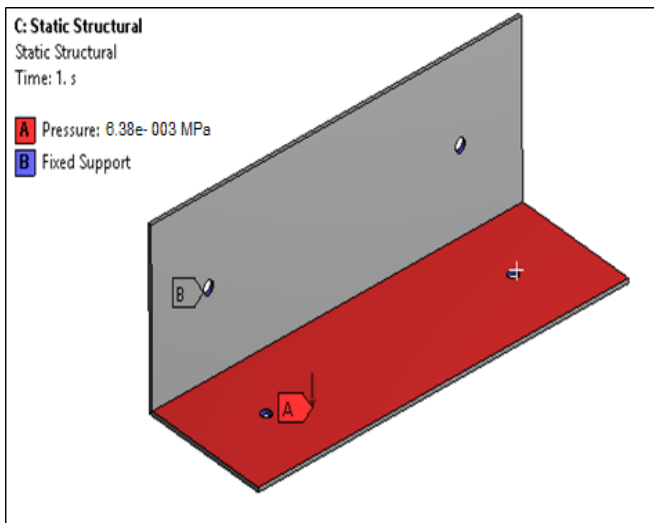

Fig.4.5:-Boundary Conditions on the GFRP bracket

Figure 4.5 illustrates the boundary conditions applied to the compression mounting bracket. A pressure of 0.006539 MPa is applied to the horizontal face, simulating a 441 N force resulting from the 3 gram loading of the weight of the compressor assembly.

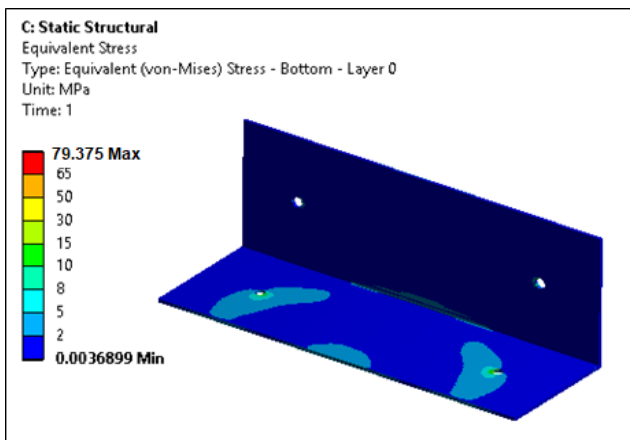

Fig.4.6:- von Mises stress plot GFRP design

The maximum von Mises stress observed in the GFRP design is 79.375 MPa, representing a point stress. This stress value falls within the acceptance criterion of 100 MPa used in the design.

The maximum deformation plot for the GFRP design indicates a deformation of 3.2483 mm. This level of deformation is considered acceptable and falls within the permissible limit for the 3 gram loading condition.

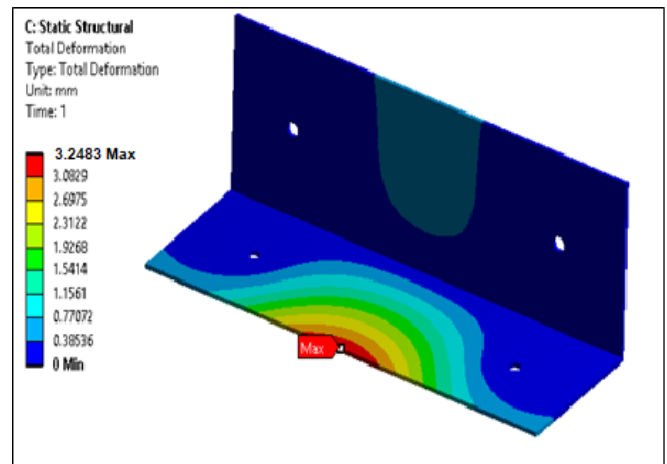

Fig.4.7:- Maximum deformation plot for GFRP design

### 4.3 Modal Analysis for Steel and GFRP

Modal analysis is conducted on both the steel and GFRP brackets to determine the lowest natural frequency of the bracket under operating boundary conditions. The purpose of modal analysis is to ensure that the design modifications made in the material do not adversely affect the system's first or lowest natural frequency. Decreases in the natural frequency can lead to dynamic resonance in the component, as low-frequency time-dependent loading may result in sudden premature failure of the bracket.

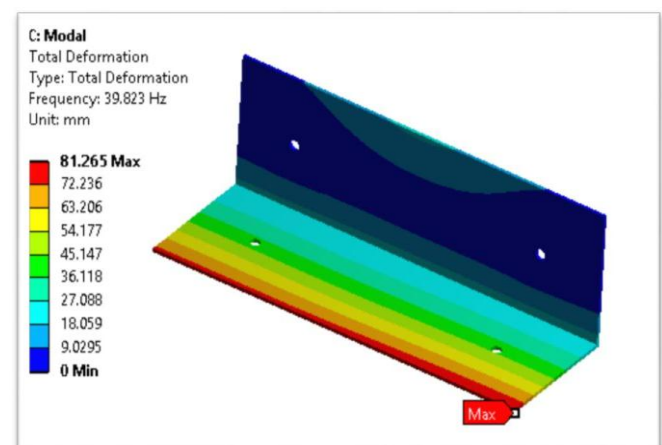

Fig.4.8. Mode shape plot at 1<sup>st</sup> natural frequency of steel bracket 39.823 Hz

The mode shape plot illustrates the deformation pattern associated with the first natural frequency for both the Steel and GFRP brackets. It is important to study the shape of deformation rather than focusing on the specific deformation values displayed in the plot. The deformation values themselves do not convey significant information, as the primary objective is to analyze and understand the mode shape for the first modal frequency.



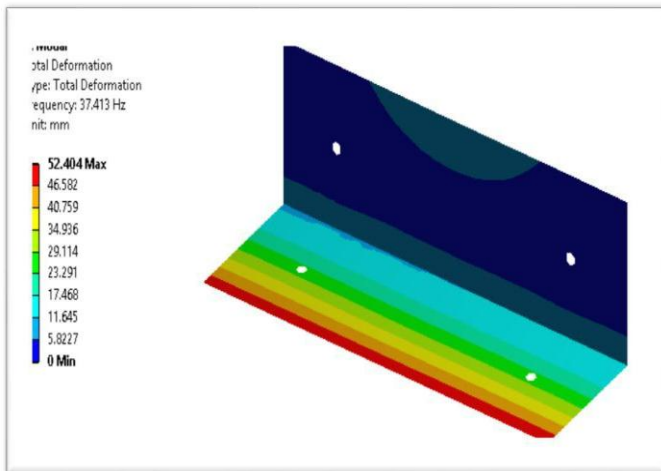

Fig.4.9. Mode shape plot at 1<sup>st</sup> natural frequency of GFRP bracket 37.413 Hz

### 5. EXPERIMENTAL VALIDATION

For experimental validation GFRP material bracket is to be manufactured for the design dimensions.

#### 5.1 Experimentation Procedure For Testing

The experiments are performed using a Universal Testing Machine (UTM), where a load-deformation test is conducted under specified loading conditions, typically with a load of 5000N. The UTM provides results that are compared with the analysis results obtained from Finite Element Analysis (FEA).

Figure 5.1 displays a photograph of the complete experimental setup, showcasing the utilization of a computer to operate the UTM and record the load versus displacement data over time. It is worth noting that the UTM is fully automated.



Fig.5.1:- Compression loading of GFRP bracket

#### 5.2 Experimental Set up for Vibration Analysis using FFT Analyzer:

Once the natural frequency of the Compressor Mounting bracket is determined through Finite Element Analysis (FEA), it is further validated using an FFT (Fast Fourier Transform) analyzer. To simulate the actual mounting conditions in the vehicle, the bracket is mounted on a fixture. The vertical side of the bracket is attached to the fixture, replicating the boundary conditions similar to those experienced in the vehicle, while the horizontal side is left free.

#### 5.3 Results for Steel Bracket:-

Table 5.1. Result for Steel Bracket

Rpm	Acceleration m/(s <sup>2</sup> s) (overall rms)	Velocity mm/s (peak)	Displacement um (pk-pk)
100	12.4203	25.5349	297.9504
200	15.2623	47.6635	413.3204
300	16.9701	32.6739	330.2616
400	17.6031	26.0352	222.9477
500	18.1271	26.8332	60.5819
600	15.6892	29.9485	125.9852
700	19.8294	34.6446	215.2648
800	21.4861	31.3476	106.5486
900	20.8524	33.9148	80.2465

Thus the rpm of motor increases acceleration and displacement get change i.e steel has more displacement.

#### 5.4 Results for GFRP Bracket:-

Table 5.2 .Result for GFRP

Rpm	Acceleration m/(s <sup>2</sup> s) (overall rms)	Velocity mm/s (peak)	Displacement um (pk-pk)
100	9.6203	32.0379	235.5620
200	10.1550	32.1732	345.8054
300	11.7532	15.2034	265.3466
400	14.2972	17.6303	169.0902
500	16.2631	19.3567	58.7726
600	14.9485	21.2651	111.6326
700	16.6585	24.3265	187.3526
800	18.6594	20.3265	74.6352
900	17.2150	26.3265	63.6215

Thus the rpm of motor increases acceleration and displacement get change. ie less displacement then steel.

**5.5 Noise measurement for steel:-**

Table 5.3.Noise Measurement for Steel

Speed (rpm)	Noise (dB)
100	78
200	80
300	83
400	86
500	89
600	89
700	91
800	93
900	95

Noise measurement of steel increases by motor rpm but it is comparatively more than GFRP material.

**5.6 Graph of noise measurement for steel bracket:-**

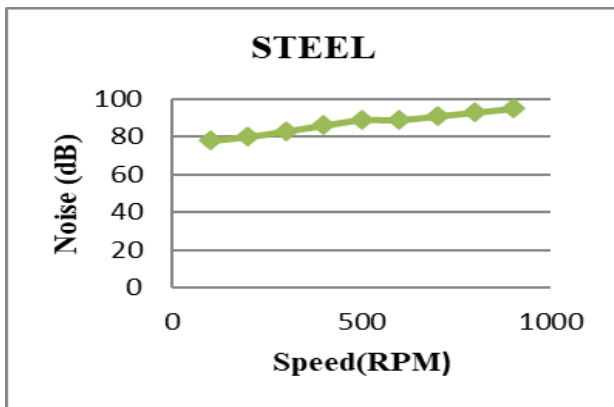

Graph 5.1. Noise measurement for Steel

**5.7 Noise Measurement of GFRP Bracket:-**

Table 5.3. Noise Measurement for GFRP

Speed	Noise (dB)
100	72
200	74
300	76
400	79
500	82
600	84
700	86
800	87
900	89

Noise measurement of GFRP material is less than the steel

**5.8 Graph of noise measurement for steel:-**



Graph 5.2. Noise measurement for GFRP

**6. RESULT AND DISCUSSION**

The FEA results table presents a comparison between the steel and GFRP material designs of the bracket. Upon analyzing the results, the following observations can be made:

Table 6.1. FEA Results Summary

**REFERENCES**

Iteration	FEA Max Stress (MPa)	FEA Max deformation (mm)	Weight (grams)	% Material Reduction
Steel	61.834	0.3275	3920	0
GFRP	79.375	3.2483	1300	66.67%

1. Dr. K Rambabu, "Study of Design and Analysis of Air Conditioner Compressor Mounting Bracket", International Journal of Science and Research (IJSR) ISSN (Online): 2319-7064.
2. D. Singh, J. S. Saini, "Dynamic Analysis of Condenser Assembly of Automobile Air Conditioning System Using CAE Tools", Springer, J. Inst. Eng. India Ser. C (April-June 2013) 94(2):135-145.
3. Deshpande C., Ghatekar A., "Design of Compressor mounting Bracket using optimization", International Journal of Advanced Information Science and Technology (IJAIST) Vol.13, No.13, May 2013.
4. Doo-Ho Lee, Jeong- Woo Chang, Chan- Mook Kim, "Optimal Shape Design of an Air Conditioner Compressor Mounting Bracket in Passenger Car", SAE Noise and Vibration conference, 2003.
5. Gabriel-petru anton, mihai paval, fabien sorel, "application on an updated finite element model of an engine in the automotive industry" sisom 2011 and session of the commission of acoustics, bucharest 25-26 may.
6. S.K. Loh a, W.M. Chin a, Waleed F. Faris, "Fatigue analysis of Package Terminal Air Conditioner motor bracket under dynamic loading", Materials and Design 30 (2009) 3206-3216.
7. Doo-Ho Lee, Jeong - Woo Chang, Chan - Mook Kim, "Optimal Shape Design of an Air-Conditioner Compressor Mounting Bracket in a Passenger Car," SAE International, 2003-01-1667.
8. Hong Suk Chang, "A Study on the Analysis Method for Optimizing Mounting Brackets," SAE International, 200601-1480.
9. Mahendra M. Gaikwad, "Bracket Document 112978," Coventry Engineers, UK.

Table 6.2. Deformation FEA & Experiment

	FEA For Steel	Experimental For steel	% Error	FEA For GFRP	Experimental For GFRP	% Error
Deformation	3.3573	3.6128	6.23%	0.32792	0.34	3.01%

The summary table of the Finite Element Analysis (FEA) results shows that the maximum pressure observed in the steel section is 61.834 MPa, which falls comfortably within the acceptance criteria for the steel design. Similarly, for the GFRP design, the FEA indicates a maximum pressure of 79.375 MPa, which is within the acceptance criteria specified for the GFRP material.

**7. CONCLUSION**

By utilizing GFRP material, a significant weight reduction of up to 66.67% is achieved, with the bracket weighing only 1.3 kg compared to the conventional material.

- The first natural frequency of the GFRP design is determined to be 37.413 Hz, which is 2.4 Hz lower than the previous steel design of the mounting bracket.
- Among all the analyzed combinations of layup angles, the best angle combination selected as the optimal alternative was 90 degrees.
- Deformation is reduced by 90.23% when using GFRP material compared to steel material.
- When assessing vibration in terms of motor rpm connection to probe acceleration and displacement, the GRFP material exhibits lower levels compared to the steel material.