

Design and Implementation of Isolated Zeta-Luo Converter for EV Charging Applications

PRACHI SINGH¹, ABHISHEK KUMAR SINGH², SRAJAN S KUMAR³, DIVYANSHI SHARMA⁴

¹Student, Department of EE, JSS Academy of Technical Education, Noida, Uttar Pradesh

²Assistant Professor, Department of EE, JSS Academy of Technical Education, Noida, Uttar Pradesh

³Student, Department of EE, JSS Academy of Technical Education, Noida, Uttar Pradesh

⁴Student, Department of EE, JSS Academy of Technical Education, Noida, Uttar Pradesh

Abstract - This study presents a novel approach to designing a charger for battery electric vehicles (BEVs) by utilizing an enhanced Zeta-Luo converter. The Zeta-Luo converter, a modified combination of the Zeta and Luo converters, is specifically tailored to operate during individual halves of the supply voltage, thereby improving power quality at the output. The key advantage of this design lies in its ability to enhance charger efficiency compared to other converters, while ensuring a consistent charging current for the battery. Both the improved Zeta converter and the Luo converter are set to operate in discontinuous conduction mode (DCM), which brings about cost and size reductions. The proposed model will be developed using MATLAB/Simulink.

Key Words: Zeta Converter, Luo Converter, Zeta-Luo Converter, Discontinuous Conduction Mode, EV Charging, Power Quality

1. INTRODUCTION

DC-DC converters have undergone extensive development over the past six decades and have found widespread use in industrial applications and computer circuits. With the electronics industry trending towards low voltage and high-power density, the technology has witnessed rapid advancements and significant transformations. The DC-DC converter market is experiencing a faster growth rate of 7.5% compared to the AC-DC power supply market. While a simple voltage divider can serve as a basic DC-DC converter, it suffers from poor efficiency and can only transfer output voltage lower than the input voltage. To overcome these limitations, the multiple-quadrant chopper emerged as the next stage in DC-DC conversion, aiming to convert DC energy between different voltage levels. This bears similarity to the function of a transformer in AC-AC conversion.

In the current era, addressing environmental concerns, particularly pollution from hydrocarbon gases in transportation, has become a crucial issue. To promote green transportation, electric vehicles are being vastly adopted. Within electric vehicles, the DC-DC converter plays an important role in supplying power to auxiliary loads, necessitating efficient energy transfer between the high voltage and low voltage sides. This enables smooth operation and functionality for various vehicle components.

The proposed implementation incorporates synchronous rectification and soft-switching techniques, resulting in a cost-effective, flexible, reliable, and efficient solution.

The advantages of the suggested BL converter for electric vehicle (EV) charging encompass higher efficiency, a reduced component count, and the characteristic to work during both positive and negative supply cycles in either Zeta or Luo mode. This achievement is made possible by integrating two different converters and utilizing a cascaded PI controller that identifies the charging modes of the EV battery. The constant current and constant voltage modes are employed for efficient battery charging, with the PI controller ensuring a consistent charging current and voltage throughout these modes. In summary, the proposed BL converter offers a promising solution for efficient and reliable EV charging.

The application of a cascaded PI controller in the constant current-constant voltage (CC-CV) mode enables precise and stable charging of the EV battery, ensuring safety and reliability. The integration of Zeta-Luo converters during the two half cycles allows for improved efficiency and reduced switching losses, resulting in enhanced power density and overall charger performance. Furthermore, the reduced number of components and devices in the converter contributes to a more compact and cost-effective design. The utilization of discontinuous conduction mode (DCM) further enhances charger efficiency and reduces its size and cost.

2. OPERATION OF ZETA LUO CONVERTER

The selection of the magnetizing inductance value is specifically tailored to enable the converter to operate in discontinuous conduction mode (DCM), a mode known for its ability to minimize conduction losses and maximize overall efficiency. An interesting aspect of this design is that both converters utilize the same output inductors, resulting in a notable reduction in the quantity of components and devices used in the converter, resulting in a smaller size and reduced cost.

The converter's control mechanism is accomplished through the utilization of a cascaded proportional-integral (PI) controller. This controller ensures the proper charging of the battery in both the constant current and constant voltage

(CC-CV) modes. The converter exhibits commendable performance during steady-state operation, as well as under varying line voltage and load conditions. Moreover, it adheres to the recommended power quality (PQ) regulations concerning mains power factor (PF), displacement power factor (DPF), and total harmonic distortion (THD) of the supply current.

During the positive half-cycle of the supply voltage, the Zeta converter assumes the role of a buck-boost converter, with the switch S1 being activated. The intermediate capacitor C1 is charged by the magnetizing inductance Lm1, while the output diode Do1 conducts, facilitating the flow of current to the battery. Simultaneously, the Luo converter remains deactivated, and the switch S2 remains open.

In the negative half-cycle of the supply voltage, the Luo converter functions as a boost converter, with the switch S2 being activated. The magnetizing inductance Lm2 charges the intermediate capacitor C2, while the output diode Do2 conducts, allowing current to pass through to the battery. Throughout this period, the Zeta converter is inactive, and the switch S1 remains open.

Within this time frame, the voltage across capacitor C1 experiences linear growth. Once the voltage across capacitor C1 reaches its peak value Vp at time t3, the switch S2 is triggered to turn ON. This action initiates the working of the Luo converter in the negative half-cycle.

Interval-I [t0 – t1]: Within this time frame, the Luo converter is active, and switch S2 is in a conducting state. The magnetizing inductance Lm2 gradually accumulates energy from the source via diode Dn. As depicted in Figure 3(c), the voltage across capacitor C2 diminishes while the current passes through the output inductor Lo2 on the secondary side. This mode ends at time t4 when switch S2 goes in OFF state. The output diode Do2 remains non-conductive.

Interval-II [t1 – t2]: In this time interval, switch S2 goes in the OFF mode, and the conduction of diode Do2 commences. The stored energy within the magnetizing inductance Lm2 is discharged through capacitor C2, supplying power to output diode Do2 and the secondary winding of the transformer. Simultaneously, the output dc-link capacitor initiates its charging process through inductance Lo, while the battery current is regulated in the constant current (CC) mode.

Interval-III [t2 – t3]: During this time period, switch S1 remains in an inactive state, leading the converter to enter the discontinuous conduction mode (DCM). The combined currents flowing via Lm1 and the inductor at the output end Lo result in a net zero current through diode Do1, as illustrated in the diagram.

Similar operational characteristics can be observed in the Luo mode which occurs in the negative half of the supply, as depicted in Figures 1 and 2. The primary distinction lies in the DCM operation of the Luo converter, where the magnetizing inductance exhibits zero current. Figure 4 provides the corresponding waveforms of various switching elements throughout a complete switching cycle.

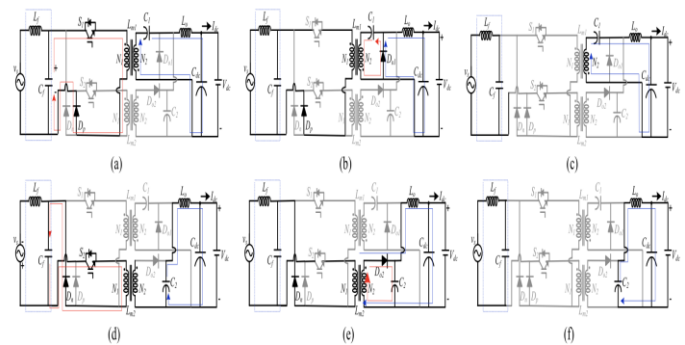

Fig -1: Switching cycles of isolated Zeta-Luo Converter

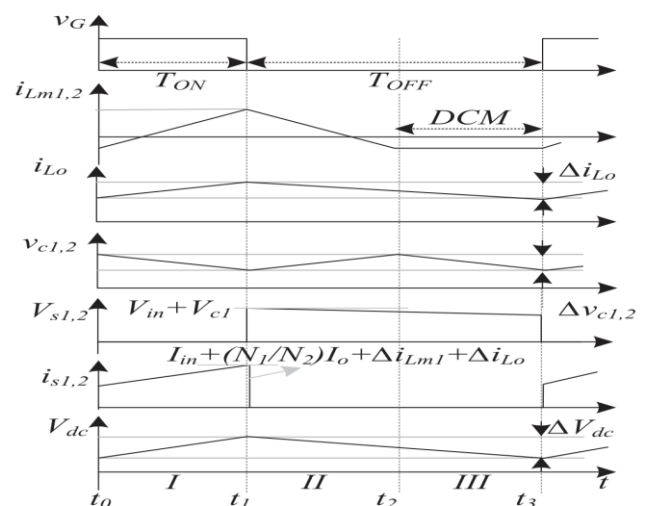

Fig-2 : Sequence of charging and discharging for various components

3.DESIGN AND SIMULATION

To evaluate the suitability of the concept for electric vehicle applications, simulation models are employed to analyze the performance on different electric loads. These models simulate real-world conditions and aim to provide accurate predictions. Below, you can find the SIMULINK models for an electric vehicle (EV) battery charger utilizing isolated Zeta, isolated Luo, and isolated Zeta-Luo converter topologies.

The purpose of conducting these simulations is to determine the most suitable converter topology for EV charging applications based on the desired output requirements.

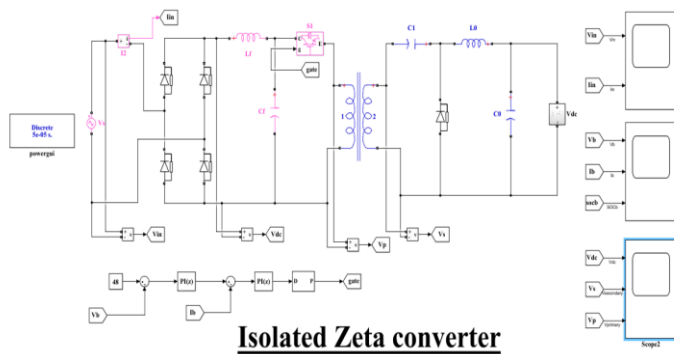

Fig 3-Simulink model of isolated Zeta converter

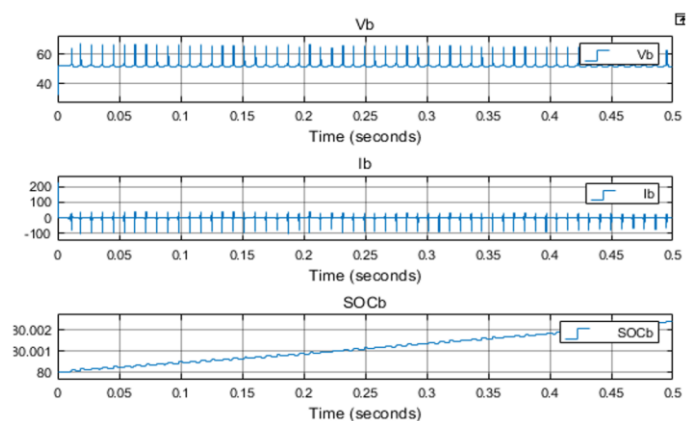

Fig 6- Output waveforms of Zeta Converter

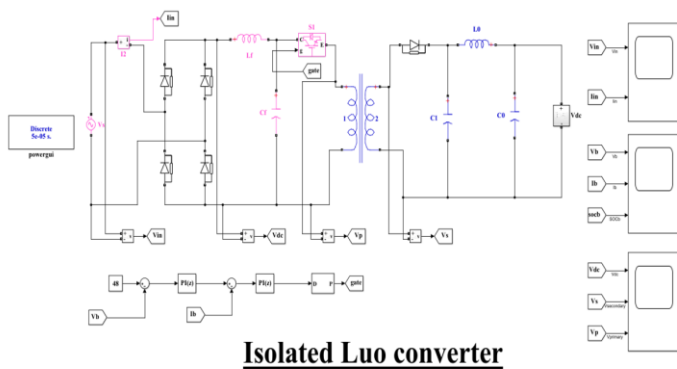

Fig 4-Simulink model of isolated Luo converter

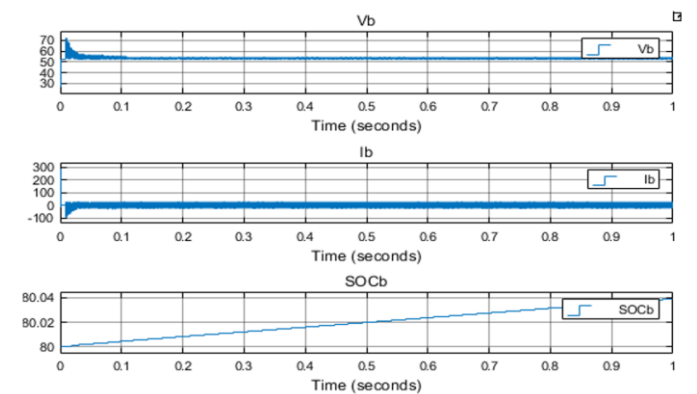

Fig 7- Output waveforms of Luo Converter

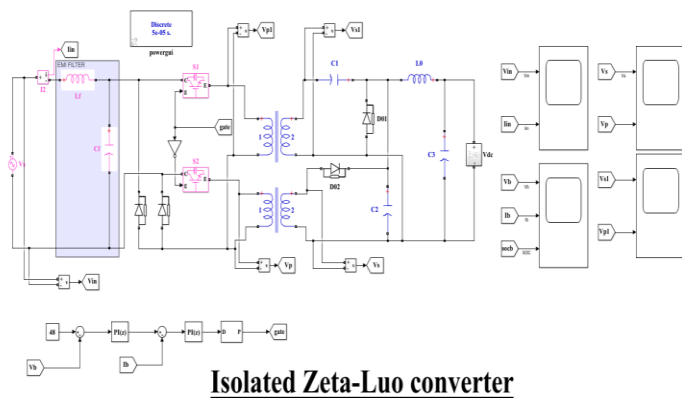

Fig 5-Simulink model of isolated Zeta-luo converter

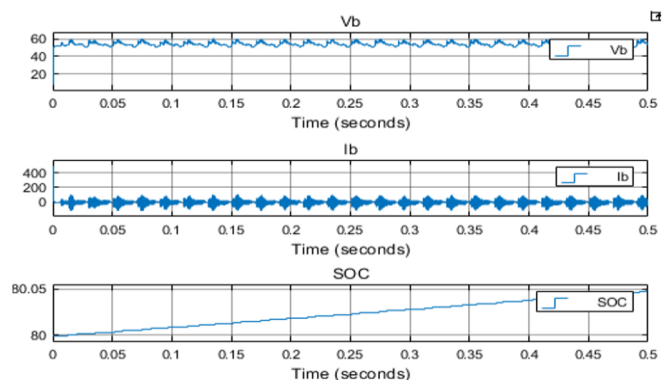

Fig 8- Output waveforms of Zeta-Luo Converter

4. CONCLUSION

An EV battery charger based on the discontinuous conduction mode (DCM) was created, utilizing an enhanced power quality (PQ)-based BL isolated Zeta-Luo converter. This innovative design combines the functionalities of Zeta and Luo converters, with each operating during distinct

halves of the supply voltage. By sharing the output inductor, this converter achieves higher efficiency compared to previous converter designs, leading to reduced charger costs and a smaller form factor. Furthermore, the inclusion of output inductances in the two converters ensures a consistent current for charging the battery, which is advantageous compared to using only Zeta or Luo converters for both cycles. The implementation of gate drive and control is simplified as both devices receive similar pulses during operation. The distortion in the source current was found to be minimal, depending on the charging mode. Overall, this new isolated converter topology represents an improved solution for EV battery charging, offering enhanced power quality characteristics.

REFERENCES

[1] Jerrold Foutz, "Switching-Mode Power Supply Design Tutorial Introduction", SMPS Technology,

<http://www.smpstech.com/tutorial/t01int.htm>, accessed: Mar 2012.

[2] Marian K. Kazimierczuk, "Pulse-width Modulated DC-DC Power Converters", Edition, Wiley.

[3] William P. Robbins, Tore M. Undeland, Ned Mohan, "Power Electronics: Converters, Applications, and Design", 3rd Edition, Wiley.

[4] B. Singh and R. Kumar, "BLDC Motor-Driven Solar PV Array-Fed Water Pumping System Employing Zeta Converter," IEEE Trans. Industry Applications, vol. 52, no. 3, pp. 2315-2322, May-June 2016.

[5] Y. Jang and M. M. Jovanovic, "State-of-the-art, single-phase, active power-factor-correction techniques for high-power applications – an overview," IEEE Trans. Ind. Elect., vol. 52, no. 3, pp. 701-708, June 2005.

[6] Sanjeev Singh, Bhim Singh, Kamal Al-Haddad, and Amrith Chandra, "Comprehensive Study of Single-Phase AC-DC power factor corrected converters with high-frequency isolation," IEEE Trans. Industrial Informatics, vol.7, no. 4, pp. 540-556, Nov. 2011.

[6] Abraham I. Pressman, "Switching Power Supply Design", Second Edition, McGraw-Hill, Publication Date: Nov 1997.

[7] Chris Mi and Hua Bai, "Comparison and evaluation of different DC/DC topologies for plug-in hybrid electric vehicle chargers," Int. J. Power Electron, vol. 4, no. 2, pp. 119-133, Feb. 2012.

[8] Chester Simpson, "Linear and Switching Voltage Regulator Fundamentals", National Semiconductor, <http://www.national.com/assets/en/appnotes/f4.pdf>, accessed: Mar 2012.

[9] V. Bist, S. Singh, G. Bhuvaneswari, and B. Singh, "Power Factor Corrected Zeta Converter Based Improved Power Quality Switched Mode Power Supply," IEEE Trans. Ind. Elect., vol. 62, no. 9, pp. 5422-5433, Sept. 2015.