

# Design, Fabrication & Performance Analysis of Solar Still for Cow Urine Distillation

Nirbhay K. Ahirrao<sup>1</sup>, Yash V. Dharse<sup>2</sup>, Siddhesh S. Khokrale<sup>3</sup>,  
Ganesh V. More<sup>4</sup>, Vikrant P. Katekar<sup>5</sup>,

<sup>1,2,3</sup> BE Mechanical Scholar, Pune Vidyarthi Griha's College of Engineering and Technology and  
G.K. Pate (Wani) Institute of Management, Pune 09, Maharashtra, India

<sup>4</sup>Prof. Mechanical Engineering Department, PVG's COET & GKPIOM, Pune 09, Pune, Maharashtra, India

<sup>5</sup>Research Scholar, Centre for Technology Alternatives for Rural Areas,  
Indian Institute of Technology Bombay, Powai, Mumbai, India

\*\*\*

**Abstract** - In this study the attempt has been made to design, fabricate and performance analysis of the passive solar still for the cow urine distillation. It is well known fact that the cow urine has huge number of medicinal values, for the purpose of distillation of cow urine the use of solar still and effect of different performance parameter is illustrated. A single slope passive solar still is designed with absorber plate dimension of 0.8 m<sup>2</sup> with 18.52° of tilt angle. The analysis of effect of different performance parameter such as water depth, wind velocity and solar radiation on the yield is experimented.

**Key Words:** Cow urine, solar still, distillation, Ayurveda, cow urine therapy, anti-toxic, detoxifying, cow urine distillation using solar still.

## 1. INTRODUCTION

"The cow urine" has the significant place in the Ayurveda and has been mentioned in "AstangaSangraha" and "SushrutaSamhita" to be the most effective product of the animal with numerous values.

The Cow Urine contains Pran shakti (Life Power). The blood of a cow is filtered into urine by its kidneys. The kidneys purify the blood. Cow urine contains the same substances as found in blood. "Matrah Sarva Bhutanam, Gavah Sarv Sukh Prada" refers to the cow, who represents Kamdhenu (one who can comprehensive all wishes of mankind), as the source of all happiness. Meaning: "Cow, the mother of all living things, gives everybody endless pleasures."

Numerous chronic and non-curable diseases can be cured using cow urine therapy. These aspects are well described in the holy scriptures such as Charak Samhita, the Atharva Veda, Rajni Ghuntu, Amritasagar, Vridhabhagabhatt, Bhavprakash, and Sushrut Samhita. In the last few years, the Cow Urine Treatment and Research Centre has conducted extensive research and come to the conclusion that it can treat a variety of illnesses, including diabetes, high blood pressure, asthma, psoriasis, eczema, heart attacks, fits, cancer, AIDS, piles, prostrate, thyroid, arthritis, migraines, ulcer, acidity, constipation, gynaecological issues, artery

blockages, ear and nose issues, abortion, and many others. [1]

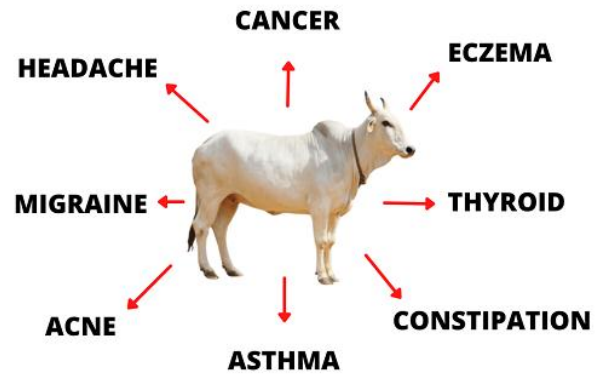

Diseases brought on by poisons are eliminated by cow urine. Cow urine can be used to disinfect a variety of hazardous compounds. The abundance of minerals like copper, gold, salts, and others found in cow urine helps the body fight off sickness. By enhancing the body's resilience to illnesses, cow urine promotes resistance in humans. This makes it anti-toxic. [2]

### 1.1 Properties of Cow Urine

Cow urine is described as being pungent, shanaviryā (hot in potency), penetrating, Laghu (easily digested), Agnidipaka (kindles digestion), and Medhya (improves intellect) in the Sushrut Samhita.

The Kshar Guna (alkaline property) prevents it from raising Vata. It elevates Pitta while bringing down Vata and Kapha. Cow urine is described as Madhur rasa (sweet) in the Charak Samhita Sutra, which in some cases relieves dosas. Gomutra is described as being both Katu rasa and Lavanaanurasa in the Astang Samgraha sutra. Pitta is heightened by ushnaviryā and rakshaguna. Compared to other animal urine, it is the best. [3]

## 1.2 Usage of cow urine.

- **Ayurvedic Medicine:** Cow urine is used in the preparation of various Ayurvedic medicines and formulations. It is believed to have detoxifying, antimicrobial, and antioxidant properties, and is used in treatments for liver disorders, diabetes, skin diseases, digestive problems, and more.
- **Panchagavya:** Panchagavya is a traditional mixture prepared using cow urine, cow dung, milk, curd, and ghee. It is used as a natural fertilizer in agriculture to enhance plant growth, control pests, and improve soil quality to enhance the quality and the output.
- **Religious and Cultural Practices:** Cow urine holds religious significance in Hinduism, and it is often used in religious ceremonies and rituals. It is considered pure and is used for purification purposes, such as sprinkling it around sacred spaces or applying it during auspicious occasions.

## 1.3 Cow Urine Distillation.

Cow urine distillation is a process that involves heating cow urine to separate its components based on their different boiling points. The urine is collected from cows and then subjected to distillation in a specialized apparatus. As the temperature increases, the volatile components in the urine, such as ammonia, urea, and various organic compounds, vaporize first. The vapor is then condensed and collected, resulting in the separation of the desired constituents from the original urine. Cow urine distillation is commonly practiced in traditional Ayurvedic medicine, where the resulting distillate, known as "Arka," is believed to possess therapeutic properties and is used in various medicinal formulations.

## 1.4 Traditional Methods of Cow Urine Distillation.

### • Gaumutrasav (Fermented preparation)

To remove the ammonia gas from cow urine, boil it first in the glass or earthen pot. Then filter it. Add jaggery and dissolve it. Then boil again. Filter it again. Keep this mixture for 15 days without disturbing it. Carefully decant the liquid (Asava) part from the top, without shaking, so that the thick part urea remains settled at bottom and decanted liquid part is transparent. 25 ml should be taken every day after meals.

### • Gaumutra Arka (Distilled Cow urine)

Cow urine vapor needs to be collected using a tube apparatus similar to how distillation vapor is collected. Cow urine is placed in an earthen or iron pot with a cover and a tube for a vapor escape and heated over a fire. The vapor is gathered in a pot after exiting this gadget through the tube. To cool the vapor and get it to condense, the pot is placed

over cold water. To keep the pot and water cold, the water beneath it needs to be changed frequently. The device's tube requires to be transparent so that the vapors may be seen. Fire or flame should be reduced if smoke begins to emerge. As a result of several components remaining in the residual and some of them being lost as vapor, the properties of ark (distilled pee) differ from those of whole cow urine or Asav. But because it doesn't smell, it is more popular [4].

## 1.5 Motivation Behind the Work.

The conventional methods used for cow urine distillation possess several limitations that hinder their efficiency and effectiveness. Here are some key limitations to consider:

1. **Low yield:** Conventional distillation methods often result in low yield due to the complex nature of cow urine.
2. **Energy-intensive:** Traditional distillation techniques typically require high energy input, primarily in the form of heat. This energy-intensive process contributes to increased production costs and environmental impact.
3. **Potential loss of volatile compounds:** Certain valuable and bioactive compounds present in cow urine can be volatile and sensitive to heat. Conventional distillation methods may lead to the degradation or loss of these compounds, reducing the overall quality and therapeutic potential of the distillate.
4. **Limited scalability:** Some conventional distillation setups are not easily scalable, making it challenging to meet increasing demand. This limitation restricts large-scale production and commercialization of cow urine distillates.
5. **Lack of standardized protocols:** The absence of standardized protocols for cow urine distillation hampers reproducibility and comparability across different studies. This makes it difficult to establish consistent quality control measures and ensure reliable results.

To overcome these limitations, there design, fabrication and performance analysis have been done on single slope passive solar still for cow urine distillation. The main objective is to utilize readily available solar energy for the distillation of the cow urine. As it reduces the energy consumption and also it has no/ low operating cost.

## 1.5 Research Objectives

- i. Solar Distiller Design.
- ii. Fabrication & Installation.
- iii. Thermodynamic Analysis.
- iv. Performance Evaluation.
- v. Technological Innovations.
- vi. Sustainability Assessment.

- vii. Reduce the energy consumption.
- viii. Reduce operational cost.

## 2. METHODS & MATERIALS

### 2.1 Assumptions.

- [1] The level of cow urine in the basin should be maintained at constant level.
- [2] The condensation that occurs at the glass trough is a film type.
- [3] The heat capacity of the glass cover, the absorbing material, and the insulation material are negligible.
- [4] No vapor leakage in the still.
- [5] No temperature gradient along the glass covers thickness and in cow urine depth.
- [6] The system is in a quasi-static condition.
- [7] The heat capacity of the insulator (bottom and side of the still) is negligible.

### 2.2 Material Selection.

Cow urine is a sophisticated biological fluid made up of several chemical elements. Water accounts for the majority of it, which is the main component. Additionally, the distinctive smell of cow urine is a result of the presence of nitrogenous substances such as urea, uric acid, and ammonia. Additionally, it contains minerals that are crucial for numerous physiological functions, include sodium, potassium, calcium, and magnesium. Organic substances such as amino acids, enzymes, hormones, and vitamins are found in trace levels in cow urine.

While designing the solar still for cow urine distillation it is imp to note that, the cow urine has the corrosion promoting properties. Also, it should be noted that the device material should not contaminate the resultant output.

**Table -1:** Material selected

Component	Material	Properties
Still Basin	Mirror	Corrosion Resistance, Reflectivity
Collector Cover	Glass	Transparent, Thermal Conductive
Glass Sealant	Silicon	Non-toxic
Drain Piping	CPVC	Non-reactive
Channel	SS304	Non-reactive, Food Grade
Structure	7216	High Structural Strength
Insulation	NBR	Wide Temp Range

### 2.3 Design Parameter.

While designing the solar still for cow urine distillation, it is necessary to consider the different parameter that should be consider such as the tilt angle of the cover plate, height of solar still, absorber plate area, thermal insulation required.

Here, according to the geological location, the tilt angle selected is  $18.52^\circ$  and after thermal calculation the absorber plate area obtained was  $0.8m^2$ .

Here the purpose of using the glass & the mirrors is that, they have good thermal conductivity & transparency of the glass & the good reflectivity of the mirror.



**Fig 2 -:** CAD Model of Solar Still

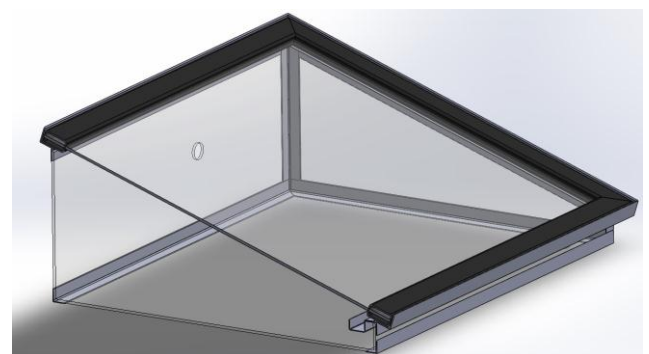

**Fig 3 -:** Cross Sectional View of Solar Still.

### 2.4 Fabrication of Solar Still.

According to our design, we selected mirrors for the construction of the basin. We cut the mirrors according to the dimensions that we already finalized. Here, the plane glass is use for the absorber plate that is to be coated with the black paint. We have used matt black paint to improve the heat carrying capacity of the absorber plate. Here, the drain port is provided with the valve to drain out the residue, for which CPVC fittings were used.

A transparent glass cover is provided on which the vapors have to condense with the Aluminium frame. The silicon selant is use to make leakproof joints. To avoid the heat losses from the side and bottom of the still basing NBR (Acrylonitrile Butadiene Rubber) is used as it has good thermal resistance ranges from  $-400c$  to  $1000c$ .



Fig -3: Fabricated Solar Still

## 2.5 Testing Procedure

1. **Experimental setup:** the experimental setup should be placed in such a way that there is no obstacle for the solar radiation to reach the absorber plate of the solar still and the flow of the wind should be undisturbed.
2. **Installation of the temperature sensors:** to get the readings of the temperatures of the different locations of the solar stills like temperature of the absorber plate, vapor temperature, glass cover temperature, atmospheric temperature etc. the RTD's should be mounted properly.
3. **Sealing:** Seal the solar still to minimize heat loss and prevent any external contamination. Ensure that the seals are secure to maintain a closed system.
4. **Data collection:** To begin, record the initial conditions, such as the outside temperature, humidity level, and solar radiation intensity. Throughout the course of the experiment, gather data at regular intervals using the appropriate sensors, data recorders, or manual measurements.
5. **Temperature monitoring:** Continuously monitor the temperature inside the solar still using temperature sensors mounted at specific locations. Measure the temperature of the fluid in the basin, the condensation surface, and the cover. Record these measurements at regular intervals.
6. **Solar radiation measurement:** Measure and record the solar radiation intensity incident on the solar still using appropriate instruments such as a pyranometer or a solar radiation meter. Ensure that the measurements are taken at the same height and orientation as the solar still.

7. **Output measurement:** Measure and record the volume of output produced by the solar still at predetermined intervals (e.g., hourly or daily). Use a measuring container with appropriate accuracy to collect and measure the distilled cow urine.
8. **Calculation:** thermal calculation to be done to analyze the different parameters such as the mass of output per hour, temperature variation according to the solar radiations and the wind velocity and the efficiency of the solar still.

## 3. EXPERIMENTAL OBSERVATIONS & RESULTS.

There are a number of performance parameters such as water depth, cover tilt angle, condensing cover cooling, reflectors, insulation that greatly affects the output of the passive solar still. A proper selection of those parameters can meet the required output demand and can improve the efficiency of the solar still.

This section illustrates the effect of those parameters on the cow urine distillation. Experimentation also aims to determine the effect of the variation of the solar radiations as time moves from morning to afternoon on the distilled output.

The results for the behavior and the performance of the solar cow urine distillation system presented in the form of graphs. Experiments have been conducted from 8:00 am to 6:00 pm by considering a wide range of parameters such as temperatures of absorber plate, temperature of cow urine, temperature of glass cover, hourly yield, vapor temperature, temperature outside of insulation, solar radiations, wind velocity etc. at these particular conditions, experiments were conducted for several numbers of days, so that comparative analysis can be done under same climatic conditions and to get the average results. According to the hourly variations of the solar radiations for the passive type solar still for the cow urine distillation for March 2023 results are illustrated.

In the fig 4, the hourly variations of the different temperatures of the components of the solar stills are compared for 10mm water depth, it can be seen that, the cow urine temperature, glass temperature, absorber plate temperature, vapor temperature, temperature outside of insulation increases gradually and reaches to maximum value in the afternoon. This is because the absorbed solar radiation exceeds the losses. The condensation of the vapor takes place, because the vapor temperature is much smaller than that of the glass temperature. In the morning hours, the glass temperature is more than the cow urine and vapor temperature causing low productivity.

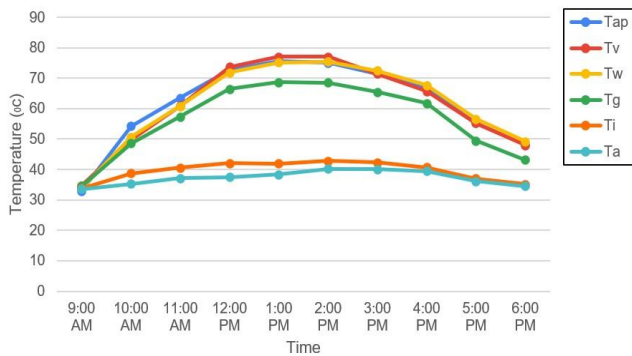

Fig 4:- Hourly variations of various temperatures.

In the fig 5, the effect of the depth of cow urine on the vapor temperature is shown. Between 9:00 am to 1:00 pm, for 10 mm of depth the vapor temperature is higher than that for the 20mm depth. But it is reverse in the evening hours between 1:00 pm to 6:00 pm. This due to the fact that, lower capacity time takes less time to raise its temperature (morning hrs.). similarly, it releases the stored energy faster than higher capacity cow urine. In the higher cow urine level maximum vapor temperature is attained in late afternoon hours. This may due to it takes much time to store energy and stores that energy for long period. It can be clearly seen in the fig 5.

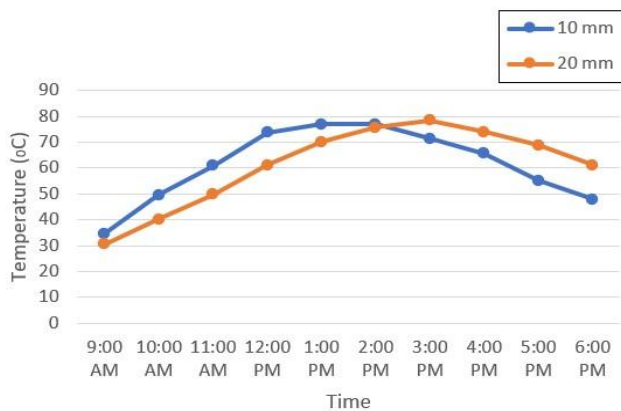

Fig 5:- Hourly variation of vapor temperature for different water depth.

In the fig 6, the effect of variation of the solar radiation on the efficiency is illustrated. Here, in the morning hours from 9:00 am to 1:00 pm as solar radiations increase the efficiency also increases steadily. In the later hours as, solar radiations decrease the efficiency start on decreasing.

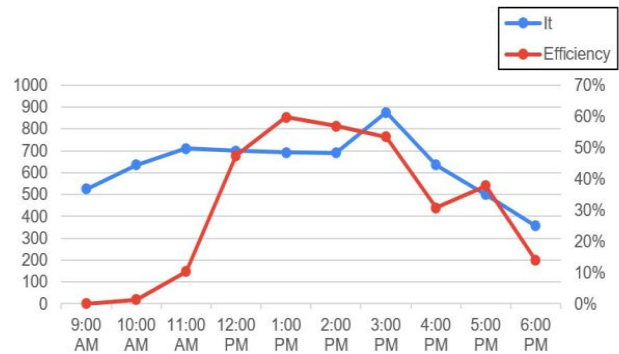

Fig 6 :- Effect of solar radiations on the efficiency

Fig 7 shows that, as temperature of the absorber plate and the vapor temperature increases slowly from morning hours (9:00 am) the yield per hours or the distilled cow urine production increases as in the midafternoon and it is maximum from 12:00pm to 3:00 pm. After these hours the yield per hours goes on decreasing in the evening hours.

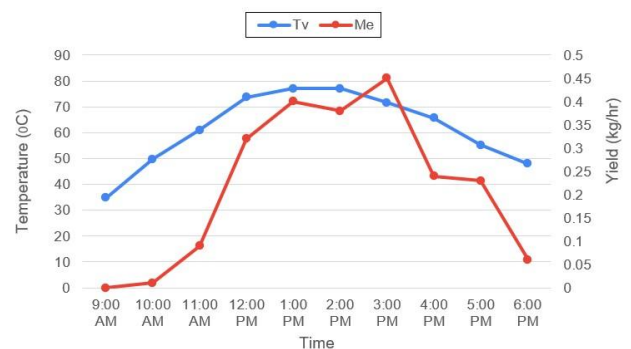

Fig 7 :- Hourly variation of yield

Hence, we get the maximum efficiency in the mid-afternoon hours from 12:00 pm to 3:00 pm. As shown in the fig 8.

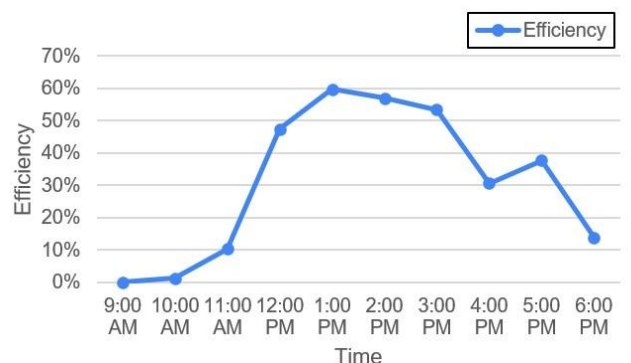

Fig 8 :- Variation of efficiency over time

#### 4. CONCLUSIONS.

From this study, number of conclusions can be obtained as follow,

- In the low cow urine level, the maximum vapor temperature is recorded in the morning hours between 9:00 am to 1:00, and it releases the stored thermal energy faster after the midafternoon than higher cow urine level.
- Lower level of cow urine gives more yield in the morning hours between 9:00 am to 3:00 am and decreases later. But In case of the higher level of cow urine we get low yield in the morning hours and is more than low in the afternoon hours.
- With 10mm cow urine depth, the maximum temperature of the absorber plate recorded in between 12:00 pm to 3:00 pm which is more than 70 OC. hence we get maximum yield of average 0.40 kg/hr. of yield in the same time frame.
- The wind velocity also plays major role on the efficiency of the system, as the wind velocity increases it lowers the temperature of the glass cover which results in increased rate of condensation.
- Hence, we can effectively use solar still system for cow urine distillation, as it has no/ less operating cost. Also it does can be operated at remote locations where other source of energy is not available for the distillation of cow urine.

#### 5. REFERENCES

- [1] N. K. Jain, V. B. Gupta, Rajesh Garg and N. Silawat, "Efficacy of cow urine therapy on various cancer patients in Mandsaur District, India - A survey," March 2010, DOI: 10.4103/0973-8258.62163.
- [2] Sonali P. Mahajan, Sarin A. Chavan, Sushilkumar A. Shinde, Mahesh B. Narkhede, "Miraculous Benefits of Cow Urine: A Review," Doi: 06.8.2020, 275-281
- [3] Sahu Rekha, Lalchand, Gupta Rakshapal and Rout Om Prakash, "BENEFITS OF COW URINE - A REVIEW", Vol. 04, Issue 09, pp.2833-2835, September, 2017
- [4] Sai Kishore.V, Lakshmana Rao.R, Ramesh.B, Aditya.K, "Indian Cow Urine Distillation and Therapeutic Uses," Vol 4, Issue 1, jan- March 2015, doi:03.12.14

#### 6. BIOGRAPHIES



Nirbhay Kiran Ahirrao  
BE Scholar at PVG's COET & GKPIOM,  
Pune 09, Maharashtra, India.  
Email Id: nirbhayahirrao99@gmail.com



Yash Vijay Dharse  
BE Scholar at PVG's COET & GKPIOM,  
Pune 09, Maharashtra, India.  
Email Id: yashdharse2001@gmail.com



Siddhesh Sandip Khokral  
BE Scholar at PVG's COET & GKPIOM,  
Pune 09, Maharashtra, India.  
Email Id: siddheshkhokrale@gmail.com



Ganesh V. More  
Department of Mechanical Engineering,  
Pune Vidyarthi Griha's College of  
Engineering and Technology and G.K.  
Pate (Wani) Institute of Management,  
Pune 09, Maharashtra, India  
Email Id: ganeshmr135@gmail.com



Vikrant P. Katekar  
Research Scholar, Centre for  
Technology Alternatives for Rural  
Areas, Indian Institute of Technology  
Bombay, Powai, Mumbai, India.  
Email Id: vpkatekar@gmail.com