

DESIGN OF ADAPTIVE TRAVEL CUP

Akhil Hayash M¹, Gokul P S², Devadarshan I³

¹Dept. of Electrical Engineering, College of Engineering Trivandrum, Kerala, India

²Dept. of Mechanical Engineering, College of Engineering Trivandrum, Kerala, India

³Dept. of Electrical Engineering, College of Engineering Trivandrum, Kerala, India

Abstract – Everyone loves travelling, But the availability of fresh water during a journey is very important. But unfortunately, we cannot drink water from the local supplies from an unknown place as it poses higher risk elements. If we go for packaged drinking water, it will be expensive and the empty plastic bottles that we need to carry will be a serious issue to both us and nature. The environmental issues from used plastic bottles is a very big issue. This paper will talk about the adaptive design of travel cup which can heat up the water up to 80 degrees Celsius and could hold that temperature for about 20 minutes, and also could hold cold beverages for the same. The dimensions are optimized to dimensions of a normal cup and the travel cup will work by using the electricity.

Key Words: Travel cup design, Adaptive equipment, Portable heater

1. INTRODUCTION

The idea of travel cup has been evolved during early 1980s. The number of travelers is increasing year by year. The travel cup has been come up with an idea to get hot water any time during a journey irrespective of place and climate. As a better and safe options, everyone chooses hot water instead of tap waters. The solution for tap waters is the packaged drinking water which will create so much environmental issues such as the plastics and empty bottles are not easy to carry. In order to obtain hot water any time they need, the travel cup has been evolved. This paper will talk about the design of an adaptive travel cup which can be used in both road trips and in house hold uses. The travel cups can be operated from the power outlets in the car and also from the house hold outlets. The travel cup posses a USB type C port which will make them universal to use. Rather than hot beverages, the travel cup could hold the cold beverages because of the thermal insulation given. The travel cup is also given with a thermistor so as to cut the supply once the required temperature is attained.

The availability of clean water will be scarce in some local places and cheapest way to access the water is the public taps which will not guaranty the cleanliness of the water. The remedy to this is the packaged drinking water. The packaged drinking water bottles are the one of the leading causes for the plastic waste especially in tourist destinations which is not good. On average in India 1 liter

of packaged drinking water costs around rupees 15 which is very expensive. Most of these waters are in cold beverage section. The availability of clean hot water is very scarce in all over India which is very limited to few places like hotels. Here makes the demand small adaptive water heater which can be used in road trips which need to small in size, to be heated small amount of water with little time and also durable and there this paper makes a talk.

2. LITERATURE REVIEW

From the proceedings of ", the design concepts of travel cup is obtained [1]. From the work done by Randy Chugh et.al (2002) "Flexible graphite as a heating element", the ideology of graphite heating is obtained [2]. From the research by Pan, Yue. (2019) "Research Progress and Application Status of Thermal Insulation Coatings", the recent advancements in thermal insulating materials is obtained [3]. From the work done by Yanping, Ye (2018) "The development of polyurethane", the application and advantages of polyurethane is taken [4]. From the research work conducted by Aleksic, Obrad et.al (2017) "Recent advances in NTC thick film thermistor properties and applications", the advancements in thermistor sensors is obtained [5]. From insights of work conducted by Kumar, Bhupender et.al (2020), "A review paper on plastic, it's variety, current scenario and it's waste management", the type of plastic used for house hold equipment is obtained [6]. From the work by ouzida, Ahcene et.al (2016). "Calculation of IGBT power losses and junction temperature in inverter drive", the IGBT characteristics is obtained [7]. From the work done by Cucchiatti, Flavio et.al (2011) "Environmental benefits of a Universal Mobile Charger and energy-aware survey on current products", the types of chargers for small electronic equipment are obtained [8].

3. SYSTEM DESCRIPTION

The shape dimensions of the proposed travel cup is given below, The travel will be having a tapered shape with the following dimensions. The steel body of the travel cup have the following dimensions and it is followed by a layer of polyurethane and which is followed by a layer of plastic.

Base radius	19.5 mm
Top radius	30 mm
Height	100 mm
Steel container thickness	1 mm
Polyurethane form thickness	2 mm
Plastic case thickness	2 mm
Volume of the container	197 ml

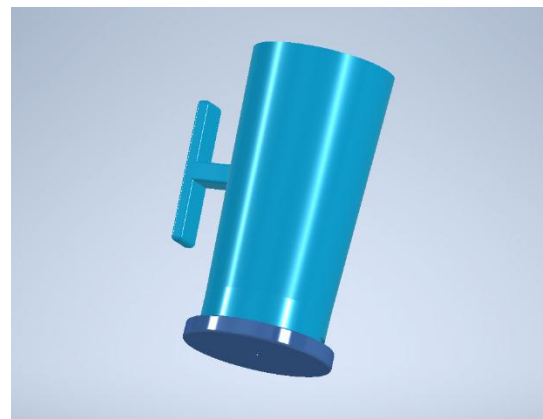

Fig -3 Travel cup coaster design

The system will consist of a charger with type C USB cable for its operation. The charger will be provided with car such as cigarette lighter plug. The travel cup also be operated using normal mobile phone chargers with fast charging capability such as 150 watts or above which are available in the market. The heating time will vary in accordance with the power rating of the charger used. From the 12 volt 10 or 15 ampere supply availed in the cars, one can heats up the 200 milli liter of water up to 80 degrees Celsius with just 4 minutes. The model of the proposed travel cup is given below,

Figure 3 represent the lid design which act like a coaster for travel cup.

4.METHODOLOGY

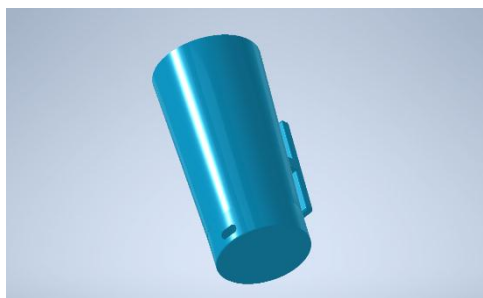

Fig -1 Travel cup design

Figure 1 represents the outline view of the travel cup. Small hole given is the USB type C charging port. The handle is provided at T cross-section so as to make it handy

The data that are used for optimizing the parameters and research works has been collected from various sources such as from research papers and other statistical data available from trusted websites and govt: bodies. The collected data are optimized on the MATLAB and all the simulations are done in the MATLAB. The simulations are conducted by assuming following conditions. The beverage in the travel cup is water. The travel cup is assumed to be filled to its maximum capacity. The outside temperature is assumed to be 27 degree centigrade.

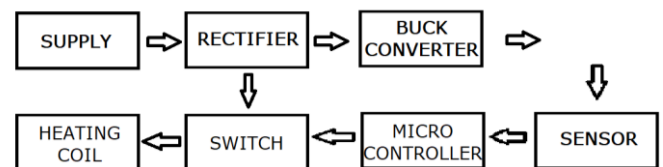

Fig -4 Block diagram of Travel cup

Figure 4 represents the block diagram of the travel cup. The supply will be main supply voltage like 230 volts. Supply will be stepped down to 12 volts. The rectifier will be bridge rectifier and LC filter is given. The 12 volts is then stepped down to 5 volts and fed to sensor as well as micro controller. The main supply (12 volts) is then given to heating coil once the parameters are meet. The required parameters are the signal from the thermistor. Once the thermistor gives required voltage, the supply to the heating coil will be cut via interpreting the signal to the gate of IGBT used for switching. The micro controller and switching circuit is setup is active low condition. The thermistor thus used is the surface mount thermistor and heating coil is made of graphite and the switching is done by an IGBT. The controlling is done by a micro controller.



Fig -2 Travel cup lid design

Figure 2 represent the lid design of the travel cup. The grooves on the lid will act as a lid as well as like a coaster for the cup.

4.1 Heating System

8

$$Q = M C dT \tag{1}$$

$$t = \frac{Q}{V I} \tag{2}$$

$$R = \frac{V}{I} \tag{3}$$

$$R = \frac{\rho l}{A} \tag{4}$$

From the equation (1) we could obtain the amount of heat energy needed to raise the temperature of beverage from room temperature to 80 degree centigrade. From equation (2) we could obtain the current that should be passed through the coil in order to generate the enough heat. From equation (3) we could find the resistance of the coil. From equation (4) we could obtain the resistivity of the coil and there by we could obtain the specific material for the heating coil.

By optimizing through all the above equations, we could reach a conclusion that, the heating coil will be graphite element with circular cross-section and having 2 mm diameter and total length of 150 mm and which is wound in a spiral manner and placed at the bottom of the travel cup for better heating and convenience.



Fig -5 Design of proposed graphite coil

Figure 5 represents the design of proposed graphite heating coil which will heats up the beverage inside the travel cup.

3.2 Brick Circuit

The circuit diagram from the brick of the power unit may subject to vary from brick to brick as the technology, manufacture and power rating of each brick varies. In general, every brick will have the following such as a step-

down transformer, rectifier, filter, converters, protection units and heat sinks which will ensure pure and safe operation of power brick. The supply to the travel cup may vary between 5-20 volts and from 1-20 ampere depends upon brick unit. The circuit inside the cup is specifically designed for these actions.

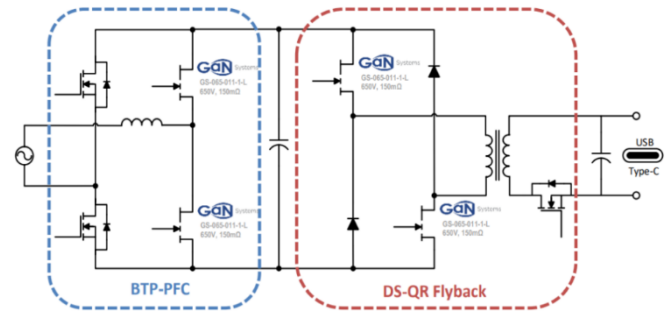

Fig -6 General brick diagram

Figure 6 [x] represents the general brick circuit diagram which uses the Gallium Nitride technology. design includes two power conversion stages – a bridgeless totem pole power factor correction (BTP-PFC) and dual switch quasi-resonant (DS-QR) flyback.

3.3 Heating Circuit

The fundamental function of the travel cup is heats the beverage in it. The equation which governs the heating circuit are:

$$1/T = 1/T_0 + 1/B * \ln(R/R_0) \tag{5}$$

$$(A) = 1 + (R_f/R_1) \tag{6}$$

From the equation (5), the output voltage of thermistor at 80 degrees centigrade is obtained which got a value of 1.36 volt. From the equation (6), the gain of the amplifier is determined. The output voltages from both thermistor and microcontroller will be amplified with a non-inverting amplifier using operational amplifiers with a gain of 4. The voltage from thermistor is raised to 5.4 volt and voltages from microcontroller to trigger the IGBT is amplified to 20 volts in magnitude. The circuitry of the heating circuit is given below,

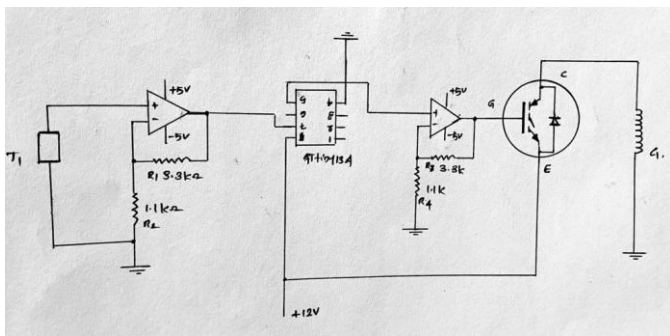

Fig -7 General Heating circuit

The figure 7 represents the general heating diagram of the proposed travel cup. The voltage from the thermistor is fed to amplifier and then to microcontroller. The microcontroller is the Attiny13A. Once the voltage from the amplifier reaches 5.4 Volts, the microcontroller will generate a continuous square pulse to trigger the IGBT gate. The gate signal will reach the IGBT after passing through a non-inverting amplifier which will make it to 20 Volts.

5.SIMULATION RESULTS

All the simulations have been done in MATLAB software. The system is heated towards 80 degree centigrade. The temperature retentivity over time is also noted. The temperature retentivity of cold beverages is also noted. All the simulations are done by considering that the beverage inside the travel cup is water. The obtained results are given below.

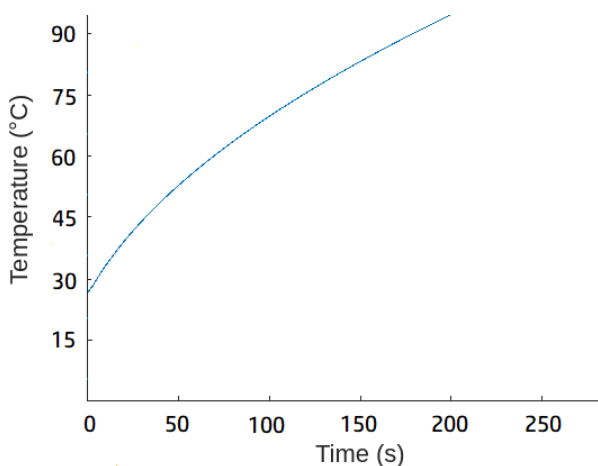

Chart -1 Heating of beverage

From the chart 1, temperature of water inside the travel can be found on different time. The chart represents temperature in degree centigrade to time in seconds. The water will reach required temperature ie: 80 degree centigrade in 175 seconds which is impressive when travelling in a car or means from the supply in a car.

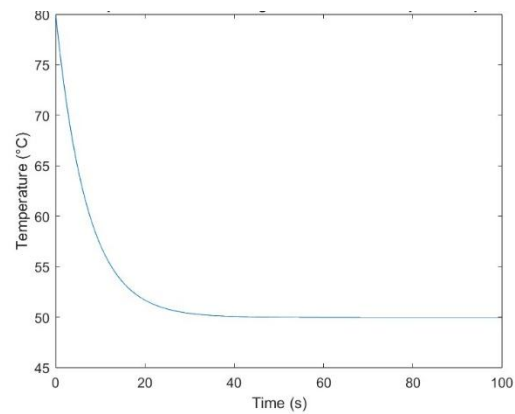

Chart -2 Heat retentivity

From the chart 2, temperature of water inside the travel cup is noted over time so as ensure the temperature retentivity of the system so that frequent heating can be avoided. The proposed travel cup could hold a temperature of 52 centigrade for long time which is one could easily consume the beverage without burning the tongue.

The heating as well as temperature retentivity of the proposed travel cup holds with industry standard heavy highly rated electric kettles which are big in size and are not easily portable and not suitable for using with a normal standard mobile charger as well as from the power outlet in the automobiles.

6. CONCLUSIONS

The proposed design of travel cup is never have been seen in the market before as the integration of universal port to the travel and ability to use this with a normal standard mobile or laptop charger with a USB Type C cable which makes this design universal. The proposed system could heat up specified amount of beverage with short period of time even from a supply inside a automobile and could retain the heat for a longer period of time with lesser losses which will avoid necessity of frequent heating. The proposed design of travel cup have been coping up with the industry leading travel cup design with minimal is cost as compared to the industry established travel cups.

REFERENCES

- [1] Alsaif, Hussain & Almaghrabi, Mohammed. (2017). Smart Travel Mug for Hot and Cold Beverages. V014T07A015. 10.1115/IMECE2017-70588.
- [2] Chugh, Randy & Chung, Deborah. (2002). Flexible graphite as a heating element. Carbon. 40. 2285-2289. 10.1016/S0008-6223(02)00141-0.
- [3] Pan, Yue. (2019). Research Progress and Application Status of Thermal Insulation Coatings. IOP Conference

Series: Earth and Environmental Science. 295.
032048. 10.1088/1755-1315/295/3/032048.

- [4] Yanping, Ye. (2018). The development of polyurethane. *Materials Science: Materials Review*. 1. 10.18063/msmr.v1i1.507.
- [5] Aleksic, Obrad & Nikolic, Pantelija. (2017). Recent advances in NTC thick film thermistor properties and applications. *Facta universitatis - series: Electronics and Energetics*. 30. 267-284. 10.2298/FUEE1703267A.
- [6] Kumar, Bhupender & Pundir, Ashok & Mehta, Vikas & Singh, Bhanu & Chauhan, Radha. (2020). A REVIEW PAPER ON PLASTIC, IT'S VARIETY, CURRENT SCENARIO AND IT'S WASTE MANAGEMENT. *Plant Archives*. 20. 53-56.
- [7] Bouzida, Ahcene & Abdelli, Radia & M'hamed, Ouadah. (2016). Calculation of IGBT power losses and junction temperature in inverter drive. 10.1109/ICMIC.2016.7804216.
- [8] Cucchietti, Flavio & Giacomello, Luca & Griffa, Gianluca & Vaccarone, Patrizia & Tecchio, Paolo & Bolla, Raffaele & Bruschi, Roberto & D'Agostino, Luca. (2011). Environmental benefits of a Universal Mobile Charger and energy-aware survey on current products. 2011. 1-9. 10.1109/INTLEC.2011.6099888.