

Automatic Hand Sanitizer Using Ultrasonic Sensor

P Annapurna¹, K Sai Pragna², D Saketh Reddy³, M Sudheer Kumar⁴

Assistant Professor, Institute of Aeronautical Engineering, Hyderabad, Telangana.

Student of Electronics and Communication Engineering, Institute of Aeronautical Engineering, Hyderabad, Telangana.

Abstract - since 2019 due to the global spread of COVID Washing hands regularly with alcohol-based hand sanitizer or soap and water every day to prevent infection and disease has become mandatory. However, it is easier to use alcohol-based hand sanitizer. But automatic disinfection dispensers are extremely user-friendly as they work without touching and 100% safe to use. Generally, automatic hand sanitizer uses ultrasonic or infrared sensors to detect the hand. When we turn on the sanitizer dispenser only 10-30% of the sanitizer or water actually touches our skin, the rest flows through the first layer of the water. Our system takes it to the next level by using a fog dispenser to make it more efficient. The main controller of the project is an ARDUINO microcontroller, SR04 Ultrasonic sensor, timer buttons, LCD display, mist maker, and UV Lamp. The UV lamp gives more efficiency in sanitizing.

Key Words: Arduino, Mist Maker, LCD Display, Ultrasonic Sensor, UV Lamp, Microcontroller, sanitization

1. INTRODUCTION

Since the start of the COVID-19 pandemic in 2019, everyone is suggested to clean their hands very frequently to reduce the spread of the disease. People can contract the COVID-19 virus by breathing in polluted air that contains the virus's aerosols, droplets, and minute airborne particles. These particles are exhaled by infected individuals while they breathe, speak, cough, sneeze, or sing. Additionally, the COVID-19 virus can be propagated by direct physical contact with surfaces.. To reduce the spread of the virus through droplets and airborne particles masks are used and to reduce the spread of the virus through contact with surfaces we need to regularly wash our hands to kill the virus. But a problem arises here with washing hands frequently that is we can't wash our hands neatly wherever we want. When we wash our hands with soap and water only 10-30% of water touches our skin and the rest flows down. Also, some soaps may not properly disinfect your hands. This might lead to lots of water wastage, which can start another pandemic- "Water Scarcity". To solve this problem, "sanitizer" has come into the scene. Sanitizer is a liquid, foam, or gel generally used to kill many viruses/bacteria/microorganisms. Sanitizer helps kill germs up to 99% on the applied surface. So, sanitizer is the most efficient way to clean hands safely.

Disinfecting our hands properly and frequently is very important to fight against the pandemic using the methods efficiently. In using sanitizer, there are also some problems

to be solved. Using the liquid form of sanitizer leads to lots of sanitizer wastage and we are not sure about the proper disinfection of our hands. To solve this problem, our machine goes a step forward saving the sanitizer using a fog-based system and assuring more safety. The main controlling device of the system is the ARDUINO microcontroller. UV lamp, timer buttons, LCD display, mist maker, and SR04 ultrasonic sensor are interfaced with the microcontroller. In this system, the user needs to set the time using the timer buttons and insert his/her hands into the machine, as soon as the ultrasonic sensor detects the hands automatically turns on the UV lamp and switches on the mist makers to dispense the sanitizer fog and the status of the process is displayed on the LCD display. The system gives the audio alert when the person removes the hands from the system displaying process is not yet finished. After the completion of the process for the provided time, it displays completed on LCD.

2. HISTORY

Hand sanitization has become a part of human day-to-day activity after once everyone faced covid. It all began in December 2019. When the covid wave started everyone understood the importance of sanitization and cleanliness. Sanitization has become a part of human life. It also played a major role against covid virus. In order to promote safety and sanitization the sale of sanitizers has increased worldwide.

2.1 PUMP BOTTLE DISPENSER

The first mode of sanitization was using a pump bottle dispenser. The image of the pump bottle dispenser is shown in Fig 1. In this method, when the person applies force and presses the pump, the sanitizer is released from the nozzle. In



Fig 1: Pump Bottle Dispenser

this mechanism, the sanitization of hands is a success but the only disadvantage in this process even after finishing the sanitization there is hand contact which again leads to the transfer of germs.

2.2 FOOT OPERATED HAND SANITIZER

In this method, the hand sanitizer mechanism is operated using a leg pump. When the person using the sanitizer uses the leg pump and applies pressure on the pump then the sanitizer is released from the nozzle. The image of Foot Operated Hand Sanitizer is shown in Fig 2. In this method, the only disadvantage is contact which leads to the transfer of germs.



Fig 2: Foot Operated Hand Sanitizer

2.3 CONTACTLESS HAND SANITIZER

In this mechanism, hand sanitizer is completely based on sensors. It is a contactless hand sanitizer. The image of contactless hand sanitizer is shown in Fig 3. In this mechanism, hand detection is done using sensors like ultrasonic, infrared, etc. When the hand is detected using the sensors microcontroller sends data to the required parts which activate the mechanism.

This means the sanitizer is released from the nozzle. Here the microcontroller that is used is Arduino. Also, this mechanism requires a constant power supply. Without the power supply, the Arduino and other components may not work. The servo motor is used to pump the sanitizer from the bottle to the user.



Fig 3: Contactless Hand Sanitizer

3 Existing Method

An automatic hand sanitizer dispenser employing an SR04 Ultrasonic sensor is part of the current method. Hands must be positioned under the nozzle in this system for the ultrasonic sensor to detect the hands and relay the information to the ARDUINO-NANO microcontroller. The Arduino-nano microcontroller has a program that uses data from the sensor as input, transmits a signal, and operates the motor pump to pump the sanitizer liquid to the water pass hose. Additionally, the LED indicator turns on to show that

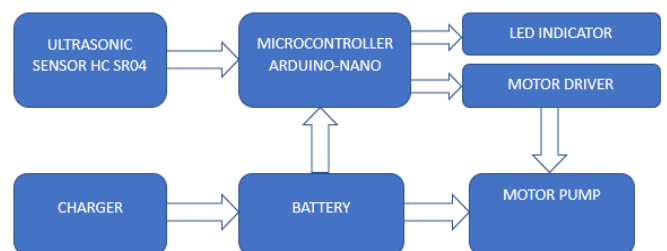

Fig 4: Block diagram

the sanitizing dispensation is happening. A little hose is used to disperse the sanitizer liquid in front of the device.

The main components used in the existing method was

- SR04 ultrasonic sensor
- ARDUINO-NANO microcontroller
- Motor pump

- Motor driver
- Charger Battery
- LED

The block diagram is shown in Fig 4, The ultrasonic sensor detects the hands, and the sensor sends the input to the microcontroller ARDUINO-NANO. The Arduino-nano microcontroller has a program to access data from the sensor as the input, sends a signal, and drives the motor pump to pump the sanitizer liquid to the water pass hose, also the LED indicator turns on indicating that the sanitizer dispensation is in process. The sanitizer liquid is dispensed through a small pipe in front of the appliance.

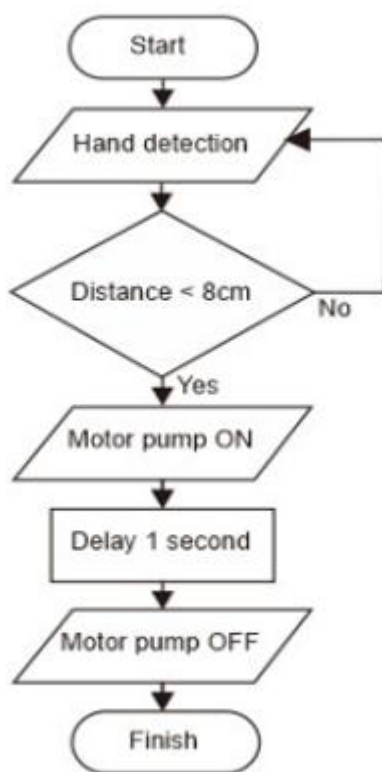

Fig 5: flow chart

The flowchart of the device is shown in Fig 5. To begin switch on the power supply and The Arduino Nano serves as a central controller and receives input from the sensor if a human hand is spotted. The control center is the Arduino nano microcontroller, which includes a program to access data from the ultrasonic sensor's input. If the hand distance is less than 8cm. the sensor will detect the hand and If the hand distance is greater than 8cm from the sensor .it unable to detect. The Arduino Nano will transmit a signal and activate the pump motor when hands are detected, which will cause the liquid hand sanitizer to be pumped into the water pass pipe. A tiny pipe in front of the appliance will release the hand sanitizer liquid, and after a brief delay of one second,

the motor pump will stop and the task will be finished. The system indication can be seen by LED indicators. The red light in the system indicates that the system is in standby mode. The green light in the system indicates that the sanitizer is being released from the nozzle at that time. One of the disadvantages of this system is that it is a battery-based system. So the system needs a constant battery or power supply. The batteries used in this system are rechargeable such that the batteries can be recharged constantly and can be used multiple times.

4 Problem Identification and Solution

With this existing method, there are high chances of facing several problems related to disinfection rate, safety, usage of sanitizer, etc. In this existing method, by using liquid sanitizer lots of sanitizer is wasted. When the liquid sanitizer is dispensed, only some amount of sanitizer touches the surface of your hands, and the remaining flows down over the first layer of the sanitizer on the hands, which may also make the area so messy. The existing system also does not know when to stop dispensing, hence wastage of sanitizer is more. Another problem is the fewer safety measures. Using sanitizer germs are killed, but there are chances of less safety and the need to increase the safety measures for complete disinfection of germs on hands. Also, there are chances for less safety due to human-made errors like removing the hand before complete disinfection or not placing hands properly. In such cases, proper disinfection does not happen and high chance for less safety. One can not know whether his/her hands are properly sanitized or not. These problems may become the major reasons for the fewer safety measures.

To overcome all these problems we have come up with some solutions to reduce the wastage of sanitizer, increase safety measures and reduce human-made errors. First, to reduce the wastage of sanitizer we introduced mist makers in our system consuming 95% less sanitizer. These mist makers convert the liquid form of sanitizer to the form of fog. By using the sanitizer in the form of fog, a very less amount of sanitizer is used to disinfect and hence wastage is very less. To increase the disinfection rate and safety measures we have introduced the UV lamp in our system. UV lamps are used very often to reduce the spread of viruses or bacteria by disinfecting them. Hence using UV lamp safety is improved. And to reduce human-made errors we introduced timers and buzzers into our system. The timers are used as the timer input to the system and based on the timer input the system runs. We have inserted four-timer buttons for 5 seconds, 10 seconds, 15 seconds, and 20 seconds. If the hands are removed from the systems within the given time or hands are not detected, using the buzzers audio alerts are given indicating that the process is not yet finished. So using these timers and buzzers system makes sure for proper and complete disinfection.

5. Proposed system

The main controlling device of the project is the Arduino microcontroller. SR04 ultrasonic sensor, timer buttons, LCD display, Mist maker, Buzzer, and UV lamp is interfaced with the microcontroller. Users need to set the time through buttons. After selecting the time user inserts the hands into the machine.

Automatically detects the hands using an ultrasonic sensor and based on the selective time the machine switches on the mist makers (fog sanitizer) and UV lamp. If the person removes the hands from the working machine then the system gives the alerts in the form of a buzzer. The status of the project will display on LCD. To perform this intelligent task microcontroller loaded embedded C language.

5.1 BLOCK DIAGRAM

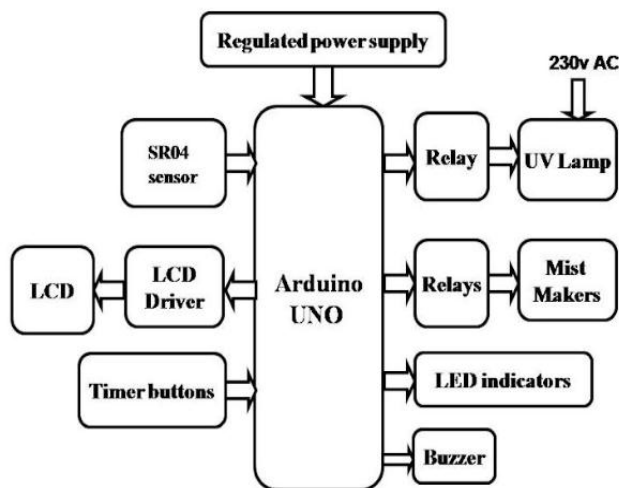

Fig 6: Block diagram

The block diagram is shown in Fig 6. The base block here represents the microcontroller, which is the Arduino UNO. The Ultrasonic sensor, timer button, LCD display, mist maker, buzzer, and UV lamp are connected to the microcontroller. This process will start when a hand is detected. In this project, the main input is the detection of hands obtained from the ultrasonic sensor. It then sends the signal to the microcontroller and excites the relay. Relays are typically used in control panels, manufacturing, and building automation to switch the smaller current values in a control circuit and control the power. The UV Lamp and the Mist Maker are going to take part in their process. And if a timer has not been completed it gives the buzzer alert and the status of the project is displayed on an LCD display.

6. IMPLEMENTATION

6.1 HARDWARE IMPLEMENTATION

In Fig 7, the circuit is shown where the digital pin of the Arduino is connected to the SR04 Ultrasonic sensor, Relay, LCD Display, and even buzzer. The power source that changes irregular AC (Alternating Current) into continuous DC (Direct Current) uses a regulated power supply. The output is kept constant even if the input changes thanks to a regulated power supply. is connected to the General pin of the 5v pin and the timer button is connected to the digital pins of the Arduino UNO. All pins are connected through metallic wires. The ultrasonic sensor of SDA and SCL are both concurrently wired to the data pin and the clock pin, respectively. It has traits like a simple circuit, a smaller size, more applications, and is more affordable. The input is from the ultrasonic sensor which is connected to the digital pin of Arduino UNO and the output pin is from relays. We have two outputs for this project: a fog dispenser and a UV lamp. So in hardware, we have used the two relays each one has an individual output. Where the one is connected to fog mist maker and the another is to UV lamp.

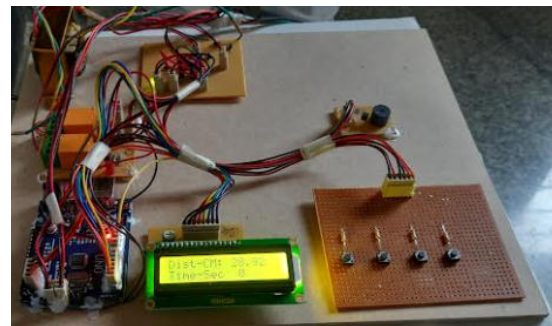

Fig 7: Hardware circuit of the device

6.2 HARDWARE REQUIREMENTS

- Regulated power supply.
- Arduino Controller
- Fog Maker
- UV lamp
- BUZZER
- LCD Display
- Timer Buttons
- Relays
- Ultrasonic sensor.

6.3 SOFTWARE IMPLEMENTATION

The software implementation of this project has two phases there are the compilation part and the simulation part. The software used for the compilation is the Arduino IDE Studio Compiler and for the simulation is Proteus 7 (Embedded C). This implementation adds to any of the Arduino on a Breadboard implementation

- We need a microcontroller with a pre-loaded Bootloader or must load your own
- Not all ATmega328's are equal

(A bootloader, very simply, is a program that sits on the chip and manages the upload of your sketches onto the chip)

We use the Arduino UNO to bootstrap the ATmega328 that is mounted on the Arduino-on-a-Breadboard for the compilation and simulation. An ATmega328P-PU can do this very easily, but an ATmega328-PU requires an additional step. In order for the Arduino UNO to burn the bootloader onto the Breadboard chip, we must program it to function as an ISP (In-System Programmer). Make sure your UNO is not linked to the Arduino on a breadboard before connecting it to the PC. "Upload the drawing after making sure that your UNO is chosen in the Boards menu section. Each microprocessor has a signature, which is a distinctive code used to identify the model. The Arduino IDE verifies that the chip you've chosen matches the kind of chip it's linked to before allowing you to bootstrap a chip or even upload a sketch. Although the ATmega328-PU essentially performs the same tasks as the ATmega328P-PU, it has a unique signature that the Arduino IDE is unable to recognize.

Select Burn Bootloader from the Tools menu to burn the bootloader. "Burning bootloader to I/O Board (this may take a minute)" should appear, as should other messages. A message indicating success is presented following the successful burning of the bootloader. Congratulations: Now that your Arduino is mounted on a breadboard, you can upload sketches to it.

7. RESULTS AND DISCUSSION

Now the system is ready to be used. In order to acquire the desired results we are going to need two sets of inputs they are

- Timer input
- Hand detection using an Ultrasonic sensor

The device will not produce any results if any one of the inputs is not given to the system. Fig – 8 explains when the system is turned on.

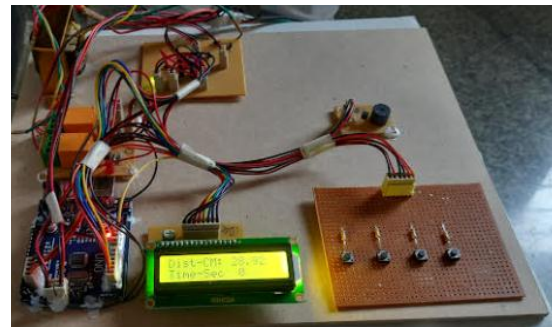

Fig – 8 Circuit Image

After the timer input is given the LCD display displays a message that the system is on. After that hands are placed inside the tunnel. Fig – 9 shows the image when the hands are placed.



Fig – 9 Hands placed inside the tunnel

The box in which the hands are placed contains the components Ultrasonic sensor, UV light, and Fog dispenser. Fig-10 depicts the components inside the box



Fig – 10 Components inside the box

When the hands are placed inside the box. They are detected using the ultrasonic sensor and the signals are sent through the Arduino UNO. When both inputs are given the UV light is turned on and sanitizer is dispensed in the fog form

and the hands are sanitized. Fig – 11 depicts the sanitization process inside the box.

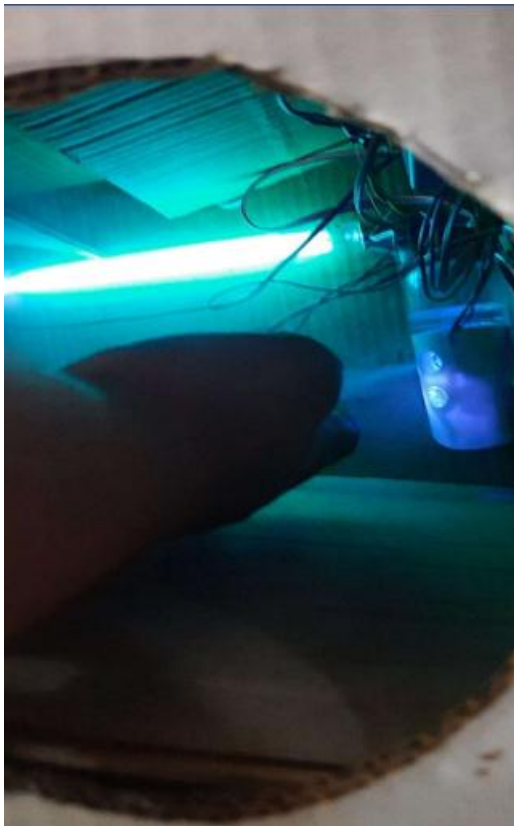

Fig – 11 Hand sanitization

In case, if the hands are removed before the timer runs out in order to provide notification to everyone a buzzer sound is activated. So when it indicates that the sanitization is not finally completed

8. CONCLUSIONS

We can conclude from all the above chapters that we achieved all the desired results. The main aim of this project is to improve the sanitization process by having minimal contact between people and having a high rate of sanitization. Finally, we achieved all these. Minimal contact is obtained using sensors and timers, which the machine runs even when someone is not there to control it. The sanitization is improved by using UV light by which the rate of protection is drastically increased. For the system to run or perform the sanitization process we are going to need two sets of inputs.

1. Timer input which is need to be given manually.
2. Hands that are placed inside the tunnel or box for sanitization.

ADVANTAGES

- Effective Hand wash.
- Up to 95% Water Saving.
- Easy To Use.
- Automatic Operation.
- Alerts in the form of a buzzer, LCD.

APPLICATION

- Mall & Theatre Washrooms
- Airport and Railway Washrooms
- School College Washrooms
- Office & Public Places

REFERENCES

- [1] Srihari, M. M. (2020). Self-Activating Sanitizer With Battery Imposed System For Cleansing Hands. 2020 Second International Conference on Inventive Research in Computing Applications (ICIRCA).
- [2] Anandu Ajayan, Sunitha Beevi. K. Automizer – An Automatic sanitizer Dispenser. 2020 IEEE International Women in Engineering (WIE) Conference on Electrical and Computer Engineering (WIECON – ECE)
- [3] Jeet Vora, Jaineel Purani, Vipin Shukla. Designing of Novel Time Monitored Touchless Operation using 555 timer for Automatic Dispenser. 5th IEEE International Conference on Recent Advances and Innovations in Engineering – ICRAIE 2020.
- [4] Iman Fushshilat; Dewi Kurnia Sari; Yoyo Somantri. Novel Design: Development of Religious Automatic Dispenser for Hand Sanitizer or Hand Washing Soap. 2020 3rd International Symposium on Material and Electrical Engineering Conference (ISMEE)
- [5] Rahul Santhosh; R. Mahalakshmi. Low-cost automatic hand sanitizer dispenser for the Covid-19 pandemic period. 2020 Third International Conference on Inventive Research in Computing Applications (ICIRCA)