

# ANTENNA ARRAYS FOR MILLIMETER WAVE COMMUNICATION: A REVIEW

Arpit Yadav<sup>1</sup>, Mr. Nadeem Ahmad<sup>2</sup>

<sup>1</sup>M.Tech, Electronic and Communication Engineering, GITM, Lucknow, India

<sup>2</sup>Assistant Professor Electronic and Communication Engineering, GITM, Lucknow, India

\*\*\*

**Abstract** - Antenna arrays are groups of antennas that are used to transmit or receive radio signals. These arrays are made up of multiple individual antennas, also known as elements, that are positioned in a specific pattern to enhance the performance of the overall system. The main advantage of antenna arrays is that they can provide a beam of radio energy in a specific direction, which can increase the strength of the signal in that direction and reduce interference from other sources. This makes antenna arrays particularly useful for applications such as wireless communication, radio astronomy, and radar systems. There are different types of antenna arrays, including linear, planar, and circular arrays, each with unique properties and applications. The specific design of an antenna array depends on the desired frequency, radiation pattern, gain, and other requirements for the system. Antenna arrays are a key component in many modern communication systems and play a crucial role in maintaining reliable and efficient wireless connectivity.

**Key Words:** beam forming; beam-scanning; millimeter-wave (mm-wave); 5G; line-of-sight (LOS); phased arrays.

## 1. INTRODUCTION

The history of antenna arrays dates back to the early days of radio communication. As early as the late 19th century, engineers and scientists were experimenting with arrays of simple dipole antennas to improve the performance of wireless communication systems. During World War II, antenna arrays became an important tool for military radar systems, which used them to detect enemy aircraft. These early arrays were often large and cumbersome, but they provided the necessary performance for the radar systems of the time. In the post-war period, the development of microwave technology and the increasing demand for wireless communication led to rapid advancements in antenna array technology. The introduction of new materials and manufacturing techniques made it possible to produce smaller, more efficient arrays that could be used in a wider range of applications. In the 1960s and 1970s, the development of computer-aided design and simulation tools revolutionized the design and analysis of antenna arrays. This made it possible to optimize the performance of arrays in ways that were previously not possible, leading to even more advanced arrays for a variety of applications.

Today, antenna arrays continue to play a critical role in modern communication systems, from cell phone networks to satellite communication systems. Advances in antenna array technology have made it possible to deliver wireless connectivity to more and more people, in more and more places, around the world.

### 1.1. Phased Array

A phased array is a special sort of antenna array that uses electronic phase shifting to guide and control the path that a beam of radio waves travels along. Phased arrays are often used in communications systems. Each antenna in a phased array is connected to a computer-controlled electrical system that alters the phase of the signals that are being sent or received by each element in the array. This allows the phase of the signals to be precisely adjusted. Because of this, the array may perform the duties of a single antenna. Because of the precise control that can be exercised over the relative phases of the signals, the phased array can generate a highly directed beam that can be aimed in a variety of directions. This is made possible by the fact that the relative phases of the signals can be precisely controlled. Phased arrays provide several major advantages over traditional antenna arrays, which are the most common kind of array. For instance, since the direction of the beam can be adjusted electronically, a phased array may be configured to follow a moving object, such as an airplane or a satellite, without the need to physically move the antenna. This eliminates the requirement for the antenna to be physically moved. This is made feasible by the fact that the beam's direction may be electrically adjusted, making it possible to achieve the aforementioned goal. Since this is the case, phased arrays are particularly useful for applications such as radar, navigation, and communication systems. Since of their adaptability, phased arrays are suitable for a diverse range of uses because they can be programmed to operate over a large range of frequency ranges. This makes them suitable for a variety of different applications. They are useful in a diverse array of applications, including military radar systems, systems for regulating air traffic, and systems for communicating by satellite, amongst others. It is now possible, with developments in digital signal processing and microwave electronics, to produce high-performance phased arrays that are more compact, efficient, and versatile than they have ever been before. These phased arrays have a broad range of potential uses in many different contexts. As a

consequence of this, phased arrays are being used in an expanding variety of applications, and it is anticipated that they will play an even more prominent part in the future of wireless communication as well as other industries that are tied to it.

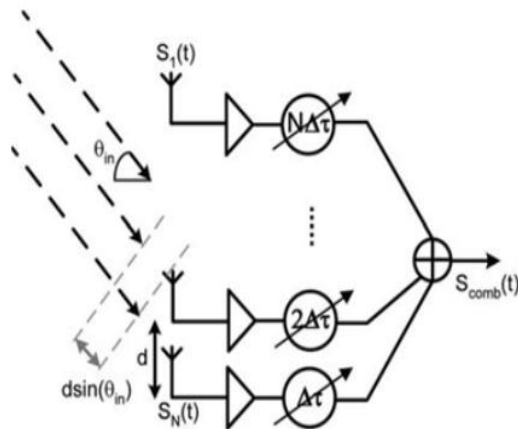

Figure-1: Block diagram of the basic phased-array receiver.

### 1.2. Millimeter-wave (mmWave) Technology

Millimeter-wave (mmWave) technology is a key enabler for high-speed 5G wireless communication. It refers to the use of radio frequencies in the millimeter range, typically between 30 GHz and 300 GHz, for wireless communication. This frequency range provides a large amount of bandwidth, which allows for very high data rates and low-latency communication. 5G wireless communication is the next generation of wireless communication technology that promises to deliver faster and more reliable wireless connectivity. It uses a combination of mmWave and traditional sub-6 GHz frequencies to provide high-speed data transmission and low-latency communication. The use of mmWave frequencies enables 5G to deliver multi-gigabit-per-second data rates, which is orders of magnitude faster than current 4G networks. The use of mm-wave frequencies for 5G wireless communication presents some unique challenges, such as high atmospheric absorption, high penetration loss through walls, and limited range. However, advances in mmWave antenna technology, such as phased arrays and beamforming, have made it possible to overcome these challenges and deliver the high-speed and low-latency communication that is the hallmark of 5G. Overall, mmWave technology is an important part of the 5G ecosystem and is playing a critical role in enabling the next generation of wireless communication. It is expected to be a key technology for many applications, including high-speed mobile broadband, enhanced mobile broadband, ultra-reliable low-latency communication, and massive machine-type communication.

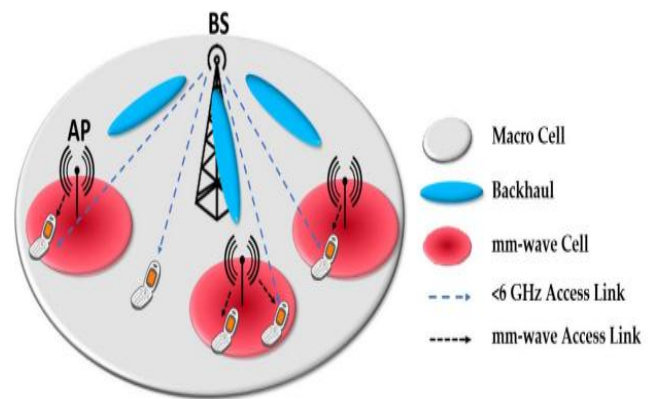

Figure-2: 5G heterogeneous mobile network scenario.

### 1.3. Millimeter-Wave Antenna Arrays for 5G Mobile Terminals

Millimeter-wave (mmWave) antenna arrays are a crucial component of 5G mobile terminals, as they enable high-speed and reliable wireless communication at mmWave frequencies. The main challenge of designing mmWave antenna arrays for 5G mobile terminals is to achieve high gain and directional performance in a compact and low-cost package.

To achieve this, mmWave antenna arrays for 5G mobile terminals typically use a combination of beamforming and beam-steering techniques. Beamforming involves the use of multiple antennas to focus the radio energy in a specific direction, while beam-steering involves adjusting the direction of the beam to track a moving target, such as a 5G base station. One of the most promising approaches to designing mmWave antenna arrays for 5G mobile terminals is the use of phased arrays. Phased arrays consist of multiple antennas that are connected to a computer-controlled electronic system that adjusts the phase of the signals being transmitted or received by each element in the array. This makes it possible to steer the beam in different directions and provide high gain and directional performance in a compact and low-cost package. Other approaches include the use of passive antenna arrays, such as parasitic arrays and patch arrays, which are simpler and less expensive than active phased arrays, but typically have lower gain and less flexibility in terms of beam steering.

In addition to the design of the antenna arrays themselves, the integration of the arrays with other components, such as the RF front-end and the modem, is also a critical aspect of designing mmWave antenna arrays for 5G mobile terminals. The goal is to achieve a compact and efficient solution that can meet the stringent requirements of 5G mobile communication while also being economically viable. Overall, the development of mm-wave antenna arrays for 5G mobile terminals is a key area of research and development, and significant progress is being made in this field. The use

of mm-wave frequencies is an important part of the 5G ecosystem and is playing a critical role in enabling the next generation of wireless communication.

## 2. LITERATURE SURVEY

In this review paper, we have studied the previous research work related to the Millimeter-Wave Antenna Arrays, and conclusion of the all research works are given below:

**Semkin et.al:** Different radii of curvature were used in simulations and measurements of a series-fed antenna array operating at 58.5 GHz. As the antenna array's supporting structure's radius is shortened, the primary beamwidth expands and the antenna array's realized overall gain drops, as proven by measurements. The obtained gain value is 17.2 dB and the high-power bandwidth is 208 for the planar case of the series-fed antenna array, whereas it is 11.4 dB and 828 for the bent antenna on the cylinder with a radius of 6 mm. The gain of the conformal antenna array that was curved around a cylinder with a radius of  $R = 6$  mm is 4 dB more than what was required for 1.5 Gbit/s data transmission. After evaluating the material losses at 60 GHz, the antenna design may be refined. The results of these models and experiments demonstrate that the optimum beamwidth of the conformal antenna array for the given situation may be determined. Antenna coverage may be expanded by making use of the beamwidth-widening feature; for example, by mounting several antenna arrays on a cylinder structure, a 3608-square-kilometer region can be covered. With enough effort, an omnidirectional radiation pattern with high gain values is possible. Beam steering may be implemented by using conformal antenna arrays with these parameters in combination with a switching network.

**Aqeel, Sungjoon:** We presented a practical example of the newly suggested phased arrays for 5G mobile terminals and access terminals. These cutting-edge phased arrays feature sufficient beam-scanning and coverage range for their inexpensive cost and small size. These cutting-edge phased arrays with three-dimensional coverage, created on single-layer and multilayer substrates, were used to demonstrate the impact of electromagnetic waves on the human body and brain. Additionally, mobile terminal space limitations and multi-polarized antenna arrays were introduced and examined. To reduce the co-channel interference and compensate for the route loss, several beamforming approaches using modern mm-wave phased array designs were developed.

**Jiang et al:** An innovative array design for beamforming and multibeam massive MIMO systems based on a metamaterial-based thin planar lens antenna was proposed. The suggested antenna is an array of antennas and an electromagnetic lens. When used with an antenna array, the EM lens boosts the throughput and data rate of massive MIMO (MIMO). PCB technology was used to create both the lens and the antenna

parts. You can see the proposed lens antenna from both the top and the side in Figure 17a,b. In the focus area behind the EM lens is a 28 GHz, seven-element stacking patch antenna supplied by a surface-integrated wire. Four square patches supplied by a SIW constitute the radiating elements of each subarray.

**Zhang et al:** Different antenna array topologies and beamforming methods for use in outdoor mm-wave communication systems were compared and contrasted. Figure 15 depicts the results of an analysis of four distinct array architectures: an 8x8 rectangle element array, a 64 circular element array, a 61 hexagonal element array, and a 16 cross-shaped element array. Figure 15 shows the 2D radiation plots that were derived from the 3D radiation patterns. The research of several array layouts reveals that the array architecture with circular components provides superior coverage in terms of both gain and directivity.

**Ayman, Hesham:** For upcoming 5G networks, a straightforward mm-wave MIMO slot antenna system consisting of two metallic arrays of three elements have been devised. The F/B ratio was increased and the backward radiation was reduced thanks to the EBG reflector. The performance analysis and design history of the proposed MIMO antenna system have been discussed. The experimental results demonstrate that the proposed design provides low envelope correlation values throughout the entire band of operation, with peak gains of over 11.5 and 10.9 dBi at the two frequencies of 28 and 38 GHz, respectively, and high isolation over wide impedance bandwidth of more than 81.7% ranging from 22.5 to beyond 50 GHz for 10 dB return loss. The suggested antenna is competitive for forthcoming 5G networks due to its small size and adequate performance.

**Tapan, Sanyog:** The suggested antenna has a bandwidth of 22.509 GHz, which is more than enough to accommodate the data rates needed for the next generation of wireless communications (5G) and beyond. The presented construction has a single layer, a flat contour, and a minimum of complicated parts. The antenna's thickness is just 0.254 mm, and its size is 96.6798.518 mm<sup>2</sup>, suggesting that it might be seamlessly integrated with the RF IC in 5G mobile devices. The manufacturing price may be kept low because of the compact shape. Side lobe levels are less than -10 dB at beam angles up to 45 degrees, demonstrating the array's impressive potential for beam steering. The antenna's gain remains relatively consistent over its usable frequency spectrum. The suggested antenna may be a suitable contender for future fifth-generation mm-Wave mobile phones because of its broadband, high gain, narrow fan beam, simplicity of integration, cheap cost, compact planar shape with a low profile, and potential to fit on constrained space available in mobile phones.



**Santos et.al:** In this study, we introduce two millimeter-wave architectures that may be used in the fifth generation of mobile phones. The first is a high-gain planar array that provides main beam modulation flexibility. The second kind is a reconfigurable 3D array that can span either a 90-degree or full 360-degree arc with a significant amount of gain. The manufacturing of both antennas, as well as the assessment of their reflection coefficient and radiation pattern in the semi-anechoic chamber at Brazil's National Telecommunications Institute, are tasks for the near future.

**Jalal et.al:** For 5G mm-wave communication systems, an antenna array with multiple inputs and multiple outputs (MIMO) is given. For this Multiple-Input Multiple-Output design, we recommend using a pair of antenna arrays. Each antenna array has four components that are evenly spaced apart, and then two arrays are put together with a 90-degree rotation concerning one another. The 37 GHz spectrum, reserved for 5G mm-wave communication, is covered by the proposed MIMO antenna array. The suggested antenna element has a gain of 6.84 dB, which may be increased to 12.8 dB using an array of four such components. Metrics for the performance of the proposed MIMO antenna array, such as the envelope correlation coefficient (ECC) and the diversity gain (DG), are measured and determined to be below the norm. Within the target operating frequency range, the suggested MIMO antenna array is shown to have a radiation efficiency of over 85%. In addition, measurements are performed on the suggested MIMO antenna array, with the findings agreeing well with the simulations. With this in mind, the suggested architecture might be considered as a possible option for 5G mm-wave communication networks.

**Aqeel et.al:** We presented a practical example of the newly suggested phased arrays for 5G mobile terminals and access terminals. These cutting-edge phased arrays feature sufficient beam-scanning and coverage range for their inexpensive cost and small size. These cutting-edge phased arrays with three-dimensional coverage, created on single-layer and multilayer substrates, were used to demonstrate the impact of electromagnetic waves on the human body and brain. Additionally, mobile terminal space limitations and multi-polarized antenna arrays were introduced and examined. To reduce the co-channel interference and compensate for the route loss, several beamforming approaches using modern mm-wave phased array designs were developed.

### 3. CONCLUSIONS

There is sufficient bandwidth, radiation patterns are steady, the realized gain is appropriate across the intended band, and flexible material substrates are used. Because of this, novel antenna architectures for the subsequent generation of communications are offered. The suggested antennas' performance is compared to that of other recently published works operating on the same frequency. The comparison

demonstrates that the suggested antennas outperform the competition thanks to the antennas' adaptability, bandwidth, steady radiation pattern, and achieved gain.

### REFERENCE

1. T. S. Rappaport, S. Sun, R. Mayzus, H. Zhao, Y. Azar, et al., "Millimeter Wave Mobile Communications for 5G Cellular: It Will Work!" *IEEE Access*, 1, May 2013, pp. 335-349.
2. E. Hossain and M. Hasan, "5G Cellular: Key Enabling Technologies and Research Challenges," *IEEE Instrumentation & Measurement Magazine*, 18, 3, June 2015, pp. 11-21.
3. T. S. Rappaport, R. W. Heath, Jr., R. C. Daniels, and J. N. Murdock, *Millimeter Wave Wireless Communications*, Upper Saddle River, NJ, Pearson Education, 2015.
4. G. Orecchini, M. M. Tentzeris, L. Yang, and L. Roselli, "Smart Shoe": An Autonomous Inkjet-Printed RFID System Scavenging Walking Energy," *IEEE International Symposium on Antennas and Propagation (APSURSI)*, Spokane, WA, USA, July 3-8, 2011, pp. 1417-1420.
5. M. Ur-Rehman, N. A. Malik, X. Yang, Q. H. Abbasi, Z. Zhang, et al., "A Low Profile Antenna for MillimeterWave Body-Centric Applications," *IEEE Transactions on Antennas and Propagation*, 65, 12, December 2017, pp. 6329-6337.
6. S. Das and D. Mitra, "A Compact Wideband Flexible Implantable Slot Antenna Design With Enhanced Gain," *IEEE Transactions on Antennas and Propagation*, 66, 8, August 2018, pp. 4309-4314.
7. M. Tighezza, S. Rahim, and M. Islam, "Flexible Wideband Antenna for 5G Applications," *Microwave and Optical Technology Letters*, 60, 1, January 2018, 2018, pp. 38-44.
8. S. Hong, S. H. Kang, Y. Kim, and C. W. Jung, "Transparent and Flexible Antenna for Wearable Glasses Applications," *IEEE Transactions on Antennas and Propagation*, 64, 7, July 2016, pp. 2797-2804.
9. A. Dierck, H. Rogier, and F. Declercq, "A Wearable Active Antenna for Global Positioning System and Satellite Phone," *IEEE Transactions on Antennas and Propagation*, 61, 2, February 2012, pp. 532-538.
10. J.-S. Park, J.-B. Ko, H.-K. Kwon, B.-S. Kang, B. Park, et al., "A Tilted Combined Beam Antenna for 5G Communications Using a 28-GHz Band," *IEEE Antennas and Wireless Propagation Letters*, 15, January 2016, pp. 1685-1688.
11. Y. J. Cheng, H. Xu, D. Ma, J. Wu, L. Wang, et al., "Millimeter-Wave Shaped-Beam Substrate Integrated Conformal Array Antenna," *IEEE Transactions on Antennas and Propagation*, 61, 9, September 2013, pp. 4558-4566.

12. Q. Jia, H. Xu, M. Xiong, B. Zhang, and J. Duan, "Omnidirectional Solid Angle Beam-Switching Flexible Array Antenna in Millimeter Wave for 5G Micro Base Station Applications," *IEEE Access*, 7, October 2019, pp. 157027-157036.
13. H. Qiu, H. Liu, X. Jia, Z.-Y. Jiang, Y.-H. Liu, et al., "Compact, Flexible, and Transparent Antennas Based on Embedded Metallic Mesh for Wearable Devices in 5G Wireless Network," *IEEE Transactions on Antennas and Propagation*, 69, 4, April 2021, pp. 1864–1873.
14. Y. J. Cheng, H. Xu, D. Ma, J. Wu, L. Wang, et al., "Millimeter-Wave Shaped-Beam Substrate Integrated Conformal Array Antenna," *IEEE Transactions on Antennas and Propagation*, 61, 9, September 2013, pp. 4558-4566.
15. H.-L. Kao, C.-L. Cho, X. Y. Zhang, L.-C. Chang, B.-H. Wei, et al., "Bending Effect of an Inkjet-Printed SeriesFed Two-Dipole Antenna on a Liquid Crystal Polymer Substrate," *IEEE Antennas and Wireless Propagation Letters*, 13, June 2014, pp. 1172-1175.
16. H.-L. Kao, C.-S. Yeh, X. Y. Zhang, C.-L. Cho, X. Dai, et al., "Inkjet Printed Series-Fed Two-Dipole Antenna Comprising a Balun Filter on Liquid Crystal Polymer Substrate," *IEEE Transactions on Components, Packaging, and Manufacturing Technology*, 4, 7, July 2014, pp. 1228-1236.
17. N. G. Alexopoulos, "Integrated-Circuit Structures on Anisotropic Substrates," *IEEE Transactions on Microwave Theory and Techniques*, 33, 10, October 1985, pp. 847–881.
18. N. G. Alexopoulos and C. M. Krowne, "Characteristics of Single and Coupled Microstrips on Anisotropic Substrates," *IEEE Transactions on Microwave Theory and Techniques*, 26, 6, June 1978, pp. 387–393.
19. N. G. Alexopoulos and S. A. Maas, "Performance of Microstrip Couplers on an Anisotropic Substrate With an Isotropic Superstrata," *IEEE Transactions on Microwave Theory and Techniques*, 31, 8, August 1983, pp. 671–674.
20. B. A. Nia, F. De Flaviis, and S. Saadat, "Flexible QuasiYagi-Uda Antenna for 5G Communication," 2021 *IEEE International Symposium on Antennas and Propagation and USNC-URSI Radio Science Meeting (APS/URSI)*, Singapore, December 2021, pp. 115–116.
21. A. Hosseini, F. De Flaviis, and F. Capolino, "A 60 GHz Simple-to-Fabricate Single-Layer Planar Fabry-Perot Cavity Antenna," *IET Microwave Antennas & Propagation*, 9, 4, March 2015, pp. 313–318.
22. N. G. Alexopoulos and N. K. Uzunoglu, "A Simple Analysis of Thick Microstrip on Anisotropic Substrates (Technical Notes)," *IEEE Transactions on Microwave Theory and Techniques*, 26, 6, June 1978, pp. 455–456.
23. S.-H. Wi, Y.-S. Lee, and J.-G. Yook, "Wideband Microstrip Patch Antenna WITH U-Shaped Parasitic Elements," *IEEE Transactions on Antennas and Propagation*, 55, 4, April 2007, pp. 1196–1199.
24. R. Kumar, R. K. Khokle, and R. R. Krishna, "A Horizontally Polarized Rectangular Stepped Slot Antenna for Ultra Wide Bandwidth With Boresight Radiation Patterns," *IEEE Transactions on Antennas and Propagation*, 62, 7, July 2014, pp. 3501-3510.