

DETECTION AND INTIMATION OF AIR POLLUTIONPERCENTAGE IN SMARTWATCH

T.Raja¹, A.S.Sharmila Devi², K.Sneha³, M.Vimala⁴, R.Yamuna⁵

¹T.Raja. Assistant Professor, Department of Electronics And Communication Engineering, Vivekanandha College of Technology for Women, Tamil Nadu, India.

^{2,3,4,5} Students, Department of Electronics And Communication Engineering, Vivekanandha College of Technology for Women, Tamil Nadu, India.

Abstract:

The level of pollution is increasing rapidly due to factors like industries, urbanization, increase in population, and vehicle use which can affect human health. An IOT-based Air Pollution Monitoring System is used to monitor air quality. When the air quality goes down beyond a certain level, indicating the presence of harmful gases like CO₂ and CO, the system triggers an alarm and vibration in a smart watch. If the harmful gases continue to increase and the oxygen level decreases, the alarm will continuously alert the user for 5 minutes. The smartwatch will make an emergency call if the oxygen level does not improve.

Keywords: *Pic-Microcontroller, CO₂ Sensor, Toxic gas sensor, GSM Module, IoT.*

1. Introduction

Air pollution can significantly impact human health, including respiratory problems, heart disease, stroke, and cancer. It can also affect the environment, such as causing acid rain, damaging crops, and reducing biodiversity. Sources of air pollution include industrial activities, transportation, burning of fossil fuels, agriculture, and natural sources such as wild fires and dust in storms. The effects of air pollution can be local, regional, or global, depending on the nature of the pollutant and its dispersion in the atmosphere. To address air pollution, governments and organizations have implemented various measures, such as regulations, policies, and programs. For example, emission standards have been implemented for vehicles and industries, renewable energy sources have been promoted, and public awareness campaigns have been launched. Individuals can also take actions to reduce air pollution, such as using public transportation, carpooling, biking, or walking instead of driving, reducing energy consumption, and properly disposing of

hazardous materials quality. A smartwatch that can detect and display air quality data would be a useful tool for people. To make this project a reality, you would need to develop a sensor that can detect pollutants and integrate it into the smart watch. The sensor could detect pollutants such as nitrogen dioxide, sulfur dioxide, ozone, and particulate matter. The data could then be transmitted to the smart watch and displayed to the user. To make the smart watch user-friendly, it should have an easy-to-read display that shows the pollution levels in real time. It could also have a feature that alerts the user when pollution levels reach a certain threshold, indicating that it's time to take necessary precautions such as wearing a mask or avoiding outdoor activities. To make the project more effective, you could also consider integrating a GPS module into the smartwatch which would allow the device to track the user's location and provide location-specific pollution data. This would be especially useful for people who travel frequently or live in areas with high levels of pollution. Overall, a smartwatch that detects and displays air quality data would be a valuable tool for individuals concerned about their exposure to air pollution. It could help make more informed decisions about when to go outside, what protective measures to take, and when to seek medical attention if necessary.

1.1 Contribution of the Work:

Air Pollution detection in Smartwatch, which measures the accurate percentage of toxic gases in the environment. It also monitors the person's health. An air quality monitoring system prototype was proposed based on the following electronic components: a microcontroller, GSM module, carbon dioxide (CO₂), and toxic gas level sensor. This device senses the quality of air and displays it in the form of a percentage. The air quality goes down beyond a certain level, indicating the presence of harmful gases like methane, and ethane that triggers the alarm and vibrates in the smartwatch. If the oxygen level decreases the alarm will continuously alert the user for five minutes. If oxygen level

does not improve that smartwatch makes an emergency call. If the oxygen improves automatically the alarm will stop.

1.2 Related works

There are several existing methods of IoT-based Air Quality Detection.

It is suggested to monitor the concentrations of different contaminants using an IoT-based real-time air pollution monitoring system. The geographical area is classified and displays the pollution level at any given location.

(i) The wearable device has sensors measuring air quality, temperature, humidity, pollutants in the atmosphere, and the user's heart rate and eventually the breath rate. Data is transmitted via Bluetooth to the user's mobile app, where it is analyzed to determine healthy exposure levels to pollution. Alerts are sent to the user through the app and device interface. The data can also predict respiratory ailments and other diseases.[1]

(ii) This system monitors the current pollution status. This will update on the web server. So, we can monitor anywhere through the Internet. The web server is also to monitor the current pollution status. Location updates are available using GPS.[2]

2. Proposed Model

Smartwatches that detect air pollution monitor the precise concentration of harmful chemicals in the atmosphere. It also keeps track of the person's health. A microcontroller, GSM module, carbon dioxide (CO2), and dangerous gas level sensors were used to create a prototype of an air quality monitoring system. This tool detects the air quality and presents it as a percentage. Beyond a certain point, the air quality deteriorates, signaling the presence of dangerous gases like methane and ethane, which sets off the alarm and vibrates the smartwatch. The user will be continuously warned by the siren for five minutes if the oxygen level drops. The smartwatch places an emergency call if the oxygen level does not rise. If the level of oxygen rises naturally, the alarm will stop.

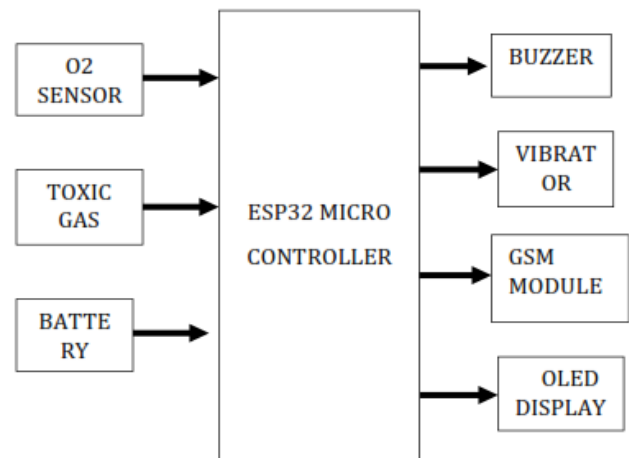

Figure 1.1 Overall Flow of the Proposed Model

- O2 Sensor: The O2 Sensor is used to detect the oxygen level in ppm.
- MQ135 (GAS Sensor): A gas sensor is used to measure the oxygen level and also measure toxic gases (methane, Ethane Sulphide, Nitrogen)
- Battery: It is an Electrochemical cell.
- PIC-microcontroller: This component is act as a main controller for the system. It receives data from the co2 Sensor and toxic gas sensor and it sends it to the IoT module for further processing.
- OLED Display: OLED Display is used to show the air pollution percentage.
- GSM Module: GSM Module stands for Global System of Mobile Application. And its application are sending and receives messages and also tracks calls and their location and also makes the emergency call.
- Vibrator: When the oxygen level decreases it gives a vibration in the smartwatch.

2.1 ESP 32 Microcontroller

The ESP32 microcontroller is a highly versatile device that combines multiple sensors into a single unit, making it easy to monitor and control various aspects of a system. With its 3 inputs and 4 outputs, it can interface with a wide range of sensors and devices, making it ideal for a wide range of applications. This microcontroller is capable of processing data from a variety of sensors, including temperature sensors, humidity sensors, pressure sensors, and more. It

can also be used to control actuators, such as motors, relays, and solenoids, making it a powerful tool for automation and control systems.



Figure 2: ESP32 Microcontroller

One of the key advantages of the ESP32 microcontroller is its low cost, making it accessible to hobbyists and professionals alike. Despite its affordability, it offers impressive performance and a range of features that make it suitable for a wide range of applications, from home automation and robotics to industrial control systems and more.

2.2 MQ135 Sensor:

Electronic devices known as gas sensors are used to identify different gases in the environment. For accurate measurement of gas concentrations in the air, the MQ135 sensor, sometimes referred to as a gas sensor, is frequently employed in air pollution monitoring systems. These sensors can pick up on a variety of gases, such as methane, carbon monoxide, and nitrogen oxides.

The main job of the gas sensor is to communicate to a microcontroller the number of parts per million (ppm) of contaminants present in the air. This data is then processed by the microcontroller to provide the current air quality index.



Figure 3: MQ 135

This air quality indicator may be seen in a variety of ways, including on smartwatches, which are increasingly popular for keeping an eye on exercise and personal health. Smartwatch percentage displays can offer a quick and simple solution to evaluate the air quality in real-time.

Gas sensors are employed in a variety of different applications in addition to air pollution detection systems, including locating gas leaks in household and commercial settings, keeping track of indoor air quality, and determining gas concentrations for use in scientific and medical research. Overall, the upkeep of a secure and healthy environment for people and other living things depends on gas sensors.

2.3 O2 Sensor

An electronic device known as an O2 sensor measures the oxygen level in human beings. 95 to 100% oxygen is considered typical. If the user's oxygen level drops, an alarm will sound continuously for five minutes, prompting them to call for help using their smartwatch. The warning will automatically cease if the oxygen level rises.



Figure 4: O2 Sensor

2.4 Battery

A battery for a smartwatch is a rechargeable battery that powers the device. Smartwatches typically have small batteries that can last anywhere from a few hours to several days, depending on the device and how it is used. The type of battery used in a smartwatch can vary, but the most common type is a lithium-ion battery. Lithium-ion batteries are known for their high energy density, which means they can store a lot of energy in a small package. They are also lightweight, which makes them ideal for use in small devices like smartwatches. The battery life of a smartwatch can be affected by a variety of factors, including the screen size and resolution, the number of sensors and features, and how often the device is used. To maximize battery life, smart watches often have features like automatic screen dimming and power-saving modes that can help conserve energy. When it comes time to recharge the battery in a smart watch, most devices come with a charging cable that can be plugged into a USB port or a wall adapter. Some smart watches also support wireless charging, which can be more convenient and eliminates the need for cables.

2.5 Buzzer

A buzzer is an electronic device that is designed to produce a loud, repeating sound. Buzzer components typically consist of a coil of wire, a magnet, and a spring-mounted diaphragm.



Figure 5: Buzzer

When the coil is exposed to an electric current, it creates a magnetic field that attracts and repels the diaphragm, causing it to vibrate and produce sound. Buzzer components can be found in a wide range of electronic devices, including alarms, timers, and electronic games. They are often used to alert the user of an event or to signal the completion of a task.

2.6 Vibrator

A vibrator is an electronic component that is designed to vibrate at a high frequency when an electric current is passed through it. Vibrators are commonly used in a wide range of electronic devices, including mobile

phones, pagers, and game controllers. Vibrators typically consist of a small motor with an eccentric weight attached to the shaft. When an electric current is applied to the motor, it causes the weight to spin rapidly, creating vibrations that can be felt by the user.

2.7 GSM Module

A GSM module is a small electronic device that allows a device to communicate over the Global System for Mobile Communications (GSM) network. The GSM network is a cellular network that is used by mobile phones and other devices to transmit voice and data. GSM modules typically consist of a modem and a SIM card slot.



Figure 6: GSM Module

The modem is used to send and receive data over the GSM network, while the SIM card slot is used to authenticate the device and allow it to access the network. GSM modules are commonly used in a wide range of applications, including security systems, industrial automation, and remote monitoring. They can be used to send and receive text messages, make voice calls, and transmit data over the network.

2.8 OLED Display

OLED technology has made major advancements in recent years not just in the field of wearable electronics, such as fitness bands and smartwatches, but also in fields like televisions, smartphones, and automobile displays. OLEDs have revolutionized how we consume and engage with digital content thanks to their higher image quality, low power consumption, and versatile design options.



Figure 7: OLED Display

In the area of environmental sensing, where it is being utilized to show crucial information about air quality and gas levels in real-time, OLED technology is one of the most promising applications. The amount of dangerous chemicals like carbon monoxide, nitrogen dioxide, and sulfur dioxide that are present in the air around you can be displayed on smartwatches' OLED screens, acting as a warning system. OLED displays can also measure blood oxygen levels, which makes them a crucial feature for hikers, sports, and persons with respiratory conditions. It is a common option for outdoor activities due to the high-contrast and bright OLED displays, which make it simple to see even in direct sunshine. In conclusion, OLED technology's adaptability has made it a crucial component of contemporary life, with uses ranging from entertainment to health monitoring. OLED displays have a promising future, and we may anticipate seeing more avant-garde applications of this technology in the years to come.

2.9 Implementation

An electrical instrument called an O2 Sensor is used to gauge the human body's O2 saturation. 95 to 100% of O2 is considered typical. The system's brain is the ESP32. The poisonous gases (sulfide, CO₂, ethane, methane, nitrogen) are detected using the MQ135 gas sensor. The O2 sensor measures the human body's oxygen content. OLED displays the gas concentration as a percentage (ppm value). If the user's oxygen level drops, an alarm will sound constantly for five minutes. If the situation persists, however, the smartwatch will dial 911. If the oxygen level rises, the alarm will automatically turn off.



Figure 8: Smartwatch

3. Conclusion:

The system to monitor the air in an environment using ESP32 Microcontroller IoT technology is proposed to detect the pollution in the air. The use of IoT technology enhances the process of detecting and intimating air pollution is proposed in this paper. Here using the MQ135, the O₂ sensor detects the different types of dangerous gas and ESP32 in the heart of this project.

References

1. Vignesh.R, DhikshaMohan, Sabarish.M "Wearable device for Air Quality monitoring with disease prediction system" January 2021.
2. D. Arunkumar, K. Ajaykanth, M. Ajithkannan, M. Sivasubramanian "Smart Air Pollution Detection And Monitoring Using IoT" 2018.
3. P. K. Hopke, S. S. Hashemi Nazari, M. Hadei, M. Yarahmadi, M. Kermani, E. Yarahmadi, and A. Shahsavani, "Spatial and temporal trends of short-term health impacts of PM_{2.5} in Iranian cities" 2018.
4. M. Iriti, P. Piscitelli, E. Missoni, and A. Miani, "Air pollution and health: The need for a medical reading of environmental monitoring data," 2020.
5. M. Kowalska, M. Skrzypek, M. Kowalski, and J. Cyrus, "Effect of NO_x and NO₂ concentration increase in ambient air to daily bronchitis and asthma exacerbation" 2020.
6. S. Ahmed, "Air pollution and its impact on agricultural crops in developing countries" 2015.
7. P. Rafaj, G. Kiesewetter, Timur Gül, W. Schöpp, J. Cofala, Z. Klimont, P. Purohit, C. Heyes, M. Amann, J. Borken-Kleefeld, and L. Cozzi, "Outlook for clean air in the context of sustainable development goals," 2018.
8. Bernasconi, S. Angelucci, A.; Aliverti, A. A Scoping Review on "Wearable Devices for Environmental Monitoring and Their Application for Health and Wellness Sensors" 2022.
9. Ali Abaas Aboodee A-Zaheere, Yasir Ahmed Taha AL-Zubaidi, S.S. Gaikwad, R.K. Kamat "Advanced Air Pollution Detection using IOT and Raspberry PI" 2020.

10. Meghana. P Gowda, Harshitha G.Y, Jyothi K.N, Srushti, Padma. R “Air Quality Monitoring System” 2021.
11. Ramik Rawal “Air Quality Monitoring System”2019.
12. Mani kannan G, Vijayalakshmi T, Prabakaran .P, “Air Pollution Monitoring System using IoT”2019.