

IoT based Smart Agriculture Monitoring System

Ajit Divakaran Mini

Department of Electronics Engineering
Shah and Anchor Kutchhi Engineering
College

Mumbai 400088, India

Minchekar Ansh Suresh Anuradha

Department of Electronics Engineering
Shah and Anchor Kutchhi Engineering
College

Mumbai 400088, India

Gupta Satyam Ramdayal Asha

Department of Electronics
Engineering Shah and Anchor
Kutchhi Engineering College

Mumbai 400088,
India

Jagdale Satyam Suyog Rekha

Department of Electronics
Engineering Shah and Anchor
Kutchhi Engineering College

Mumbai 400088, India

Mr. Santosh Kamble

Department of Electronics Engineering
Shah and Anchor Kutchhi Engineering
College

Mumbai 400088, India

Mrs. Manjusha Kulkarni

Department of Electronics Engineering
Shah and Anchor Kutchhi Engineering
College

Mumbai 400088, India

Abstract— India is an agricultural country with agriculture contributing significantly to the country's GDP [2]. However, the Indian agricultural sector is facing several challenges such as inefficient water usage, poor soil quality, and unpredictable weather conditions, which directly impact crop yield and profitability. In recent years, there has been an increasing demand for smart agriculture systems that can help farmers optimize their crop yield and reduce resource wastage [1]. In this paper, we propose an IoT-based smart agriculture robotic system that is designed to sense the temperature, humidity, and moisture levels in the soil, and transmit this data to an IoT platform via the internet. The system is also equipped with wireless and manual control capabilities via a mobile application using Bluetooth, enabling farmers to control the movements of the robotic system in real-time. Compared to the complex and expensive smart agriculture systems currently on the market, our proposed system is both cost-effective and easy to use. This allows farmers to optimize resource usage and reduce waste, and take corrective measures to prevent crop loss when soil moisture falls below a predetermined threshold. The system's rechargeable lithium-ion batteries offer a cost-effective and sustainable power supply solution, especially in rural areas with limited access to reliable electricity. Overall, this system has the potential to improve crop yield and profitability while reducing resource waste and environmental damage in the agricultural sector of India.

Keywords— Smart Agriculture system, Internet of Things (IoT), Robotic Car, Mobile application, Bluetooth

I. INTRODUCTION

The agriculture sector is one of the most important sectors in India, as it provides livelihoods for a significant portion of the population and contributes significantly to the country's economy. However, the sector faces several challenges, including water scarcity, inadequate irrigation, and a lack of real-time monitoring and control systems. In order to address these challenges, there is a need for innovative and cost-effective solutions that can enable farmers to optimize resource usage and increase crop yields.

The need to increase farm productivity has become urgent due to factors such as the exponential expansion of the global population, which would require the globe to produce 70% more food by 2050 (according to the UN Food and Agriculture Organization), shrinking agricultural lands, and depletion of finite natural resources, the need to enhance farm yield has become critical. The problem has been made worse by the limited supply of natural resources including fresh water and arable land as well as declining yield patterns in a number of essential crops. The agricultural workforce's changing organizational structure is another hindering factor. In addition, agricultural work has decreased in the majority of the nations. The demand for physical labour has decreased as a result of the shrinking agricultural workforce, which has prompted the introduction of internet connectivity solutions in farming techniques.

The traditional farming methods are no longer efficient and cannot meet the increasing demand for food production. The agricultural sector needs to modernize and embrace technology to meet the challenges. Precision agriculture is a new approach that uses

technology to optimize crop production while minimizing resource usage. IoT-powered smart agriculture systems have the potential to revolutionize the agricultural sector by providing real-time data about the crops and the environment. Such systems can help farmers make informed decisions about irrigation, fertilization, and other critical aspects of farming.[3][4]

One of the significant challenges faced by farmers is the lack of access to accurate and timely information about the crops and the environment. IoT-powered smart agriculture systems can provide farmers with real-time data about the temperature, humidity, and moisture content of the soil. The data can be used to make informed decisions about the timing and amount of irrigation and fertilization.

Another challenge is the inefficient use of resources. Farmers often use more water, fertilizer, and pesticides than necessary, leading to environmental damage and increased production costs. IoT-powered smart agriculture systems can help farmers optimize resource usage by providing data about the crop's needs and environmental conditions. Furthermore, pests and diseases are a significant threat to crop production. Traditional methods of pest and disease control involve the use of pesticides, which can be harmful to the environment and human health [3]. IoT-powered smart agriculture systems can help farmers detect and prevent pest and disease outbreaks by monitoring the crop's health and environment.

The aim of the proposed system is to provide farmers with a cost-effective and sustainable solution for precision agriculture. The system uses IoT technology to provide farmers with real-time data about the crops and the environment. The data can be used to optimize resource usage and prevent crop loss due to pests and diseases. By providing farmers with real-time data and control over their crops, the proposed system has the potential to improve crop yield and profitability while reducing resource waste and environmental damage.

II. DESIGN OF THE PROPOSED SYSTEM

A. Block Diagram:

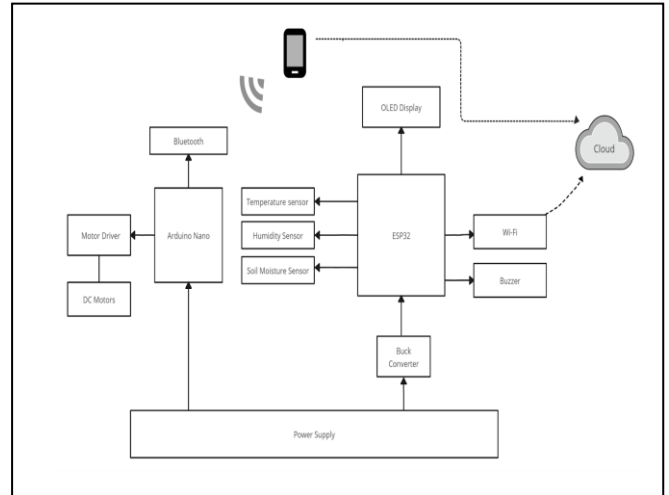

Figure 1. Block Diagram of the proposed system

B. Block Diagram Description

The block diagram of the proposed system is shown in the figure 1.1 which shows how each component in the system is connected and how they are related to each other. The hardware components are connected to each other on the basis of this diagram. This system makes use of two microcontrollers Arduino Nano and ESP32 microcontroller. The controlling unit managed by Arduino nano controls the movements and the sensing unit managed by ESP32 collects all the necessary data which accurately has to be measured before sending it over the cloud for further analysis. An inbuilt Wi-Fi feature in ESP32 helps to send the data sensed through the sensors in real time to the IoT platform Thing speak where all the history of the perceived data is stored. A customized application built to control this system enables to control the movements of robotic car and receive data from the sensor used i.e., Temperature, Humidity & Soil moisture.[5]

C. Hardware Specifications:

The hardware components of the proposed system consist of the components listed below:

- ESP32: -

The ESP32 microcontroller is a versatile and powerful module that can be used as a Wi-Fi module for IoT applications. In this paper, we propose a system that utilizes the ESP32 to sense the temperature, humidity,

and moisture levels from attached sensors and send this data over the cloud through the internet in real-time. The ESP32 is an ideal choice for this application due to its built-in Wi-Fi capabilities and powerful processing capabilities. It features a dual-core processor that can run up to 240 MHz, along with 520 KB of SRAM and up to 16 MB of flash memory. The ESP32 also supports Wi-Fi 802.11 b/g/n, making it compatible with a wide range of Wi-Fi networks. To sense the temperature, humidity, and moisture levels, we will attach a DHT11 sensor and a moisture sensor module to the ESP32. These sensors will provide accurate readings of the environmental conditions and allow us to monitor the conditions in real-time. The ESP32 will then use the built-in Wi-Fi to send this data to the cloud, where it can be accessed and analyzed in real-time. This will be accomplished using cloud-based IoT platforms such as Thing speak IoT Cloud. By utilizing the powerful processing capabilities and built-in Wi-Fi of the ESP32, we can sense the temperature, humidity, and moisture levels and send this data to the cloud in real-time, allowing for efficient monitoring and analysis of environmental conditions.[6][7]

- Arduino Nano: -

The Arduino Nano is a compact and affordable microcontroller board that can be used to control the motors of a robot car. In this paper, we present a system where the Arduino Nano is used to control the motors wheels of a robot car wirelessly in real-time. The Arduino Nano is programmed to receive commands wirelessly via Bluetooth, which is connected to the Arduino Nano. These commands are sent from a smartphone application to control the robot car's movement. The Arduino Nano then translates these commands into motor movements and controls the speed and direction of the wheels using a motor driver. This system allows for real-time wireless control of the robot car's movement, making it an ideal choice for applications that require remote control of a robot car. The Arduino Nano's compact size and affordability make it an attractive option for robotics projects.

- DC Motor & Motor Driver: -

DC motors are commonly used in robotics and other applications that require precise control of motor movement.

[6] In this paper, we present a system where a DC motor is used to control the movements of a robotic car via Bluetooth, using a motor driver L298N. The DC motor is connected to the motor driver, which provides the necessary power and control signals to the motor. The motor driver is then connected to an Arduino Nano, which receives commands wirelessly via Bluetooth from

a controller, such as a smartphone application. The controller sends commands to the Arduino Nano, which translates them into motor movements and sends them to the motor driver. The motor driver then controls the speed and direction of the DC motor, allowing for precise control of the robotic car's movements. This system allows for wireless control of the robotic car's movements, making it an ideal choice for remote control applications. The proposed system has the capability to move forward, backward, left, right, and stop on command. The use of a DC motor and motor driver ensures precise control of the robot's movements, allowing for efficient and accurate control of the robot.

- Temperature Sensor: -

The DHT11 is a low-cost digital temperature and humidity sensor module that is commonly used in various applications such as home automation, weather stations, and agricultural monitoring. The module is small and easy to use, making it an ideal choice for applications where space is limited. It has a built-in thermistor and a capacitive humidity sensor, which provide accurate and reliable temperature and humidity readings. The DHT11 is compatible with a wide range of microcontrollers, and its simple communication protocol makes it easy to integrate into projects [6]

- Lithium-ion rechargeable batteries: -

In this paper, we propose a system that utilizes four rechargeable lithium-ion batteries to power two 10rpm motors and the entire circuit. Lithium-ion batteries are a popular choice for portable devices due to their high energy density and long cycle life. The system includes two 10rpm motors that are used to drive a robotic car, as well as a range of other electronic components. The rechargeable lithium-ion batteries provide sufficient power to operate the motors and the entire circuit, ensuring that the system can operate for extended periods without the need for frequent recharging. The lithium-ion batteries are rated at 3.7 volts, which is sufficient to power the motors and other electronic components. The batteries are also rechargeable, which means they can be recharged using a suitable charging circuit. The use of rechargeable lithium-ion batteries in this system provides a reliable and efficient power source for the motors and other electronic components.

- Soil moisture sensor: -

The soil moisture sensor is a device used to measure the moisture content of soil. It is commonly used in agricultural and gardening applications to ensure that plants receive the right amount of water. The sensor consists of two probes that are inserted into the soil, and it works by measuring the resistance of the soil between the probes. The higher the moisture content of the soil,

the lower the resistance, and vice versa. The soil moisture sensor is a simple and effective tool that can help to prevent over-watering or under-watering of plants, which can lead to poor growth and yield. It is easy to use and can provide accurate measurements of soil moisture, making it an essential tool for any gardener or farmer.

- Buck Converter: -

In this paper, we propose the use of a Buck converter to provide a stable DC supply to the ESP32 microcontroller. A Buck converter is a type of DC-DC converter that is commonly used in electronic devices to provide a stable voltage supply. It works by converting a higher voltage input to a lower voltage output, while maintaining a constant power output. The ESP32 microcontroller requires a stable DC supply to function correctly, and a Buck converter is an ideal choice for this application. The Buck converter can provide a stable output voltage that is independent of variations in the input voltage, making it an ideal choice for applications that require a stable DC supply. The Buck converter also offers high efficiency, which means that it can convert the input voltage to the desired output voltage with minimal power loss. This makes it an ideal choice for battery-powered applications, where power efficiency is critical. Overall, the use of a Buck converter to provide a stable DC supply to the ESP32 microcontroller ensures reliable and efficient operation of the system, making it an essential component of the overall design.

- Bluetooth HC05: -

The Bluetooth HC05 module is a small, low-cost device that enables wireless communication between the robotic car and a mobile application. It is commonly used in a range of applications, including home automation and robotics, where wireless communication is required. In this paper, we propose the use of the Bluetooth HC05 module to enable the robotic car to be controlled via a mobile application. The Bluetooth HC05 module can be easily integrated with the microcontroller, allowing the user to control the robotic car through a mobile application. The mobile application sends signals to the Bluetooth HC05 module, which are then transmitted to the microcontroller to control the movement of the robotic car. This enables the user to control the robotic car from a distance, making it a convenient and user-friendly solution.[2][6]

- Buzzer: -

The buzzer is a simple audio device that is used to provide an audible alert in response to a signal from the moisture sensor module. In this paper, we propose the use of a buzzer to indicate the moisture content in the

soil. When the moisture sensor module detects that the soil is too dry, it sends a signal to the microcontroller, which in turn activates the buzzer. The buzzer produces a sound that is audible to the user, alerting them that the soil needs to be watered. This simple but effective solution allows the user to monitor the moisture content of the soil without having to constantly check the sensor readings. The buzzer provides a convenient and easy-to-use alert system, ensuring that the plants receive the right amount of water to grow and thrive.

- OLED display: -

The OLED display is a small, low-power display module that is used to display the temperature and humidity values measured by the DHT11 sensor. In this paper, we propose the use of an OLED display to provide real-time temperature and humidity data to the user. The OLED display is easy to read and can be used to display a range of information, including text and graphics. The temperature and humidity values are displayed in a clear and easy-to-read format, allowing the user to monitor the environmental conditions in real-time. The OLED display is also low-power, which means that it can be used in battery-powered applications without significantly affecting the overall power consumption of the system. This makes it an ideal choice for applications where power efficiency is critical.

D. Software used

The Arduino IDE software platform is used to program microcontrollers Arduino Nano and ESP32 in the proposed system mentioned in this paper. Arduino IDE provides a user-friendly graphical interface and a simplified programming language based on C/C++ to make it easy for developers to write and upload code to their microcontroller boards. The IDE includes a code editor with features such as syntax highlighting, automatic code completion, and error highlighting, making it easy to write, test, and debug code. It also has a serial monitor for real-time debugging and data visualization. With a wide range of libraries and examples available, developers can easily incorporate functionality such as reading sensors, controlling motors, and communicating with other devices into their projects. To program the Arduino Nano and ESP32 microcontrollers using the IDE, one can select the appropriate board and port settings, write the code in the code editor, and upload the code to the board using a USB cable. The Arduino IDE is a popular and versatile platform for programming microcontrollers, making it an ideal choice for both beginners and experienced developers in various projects.

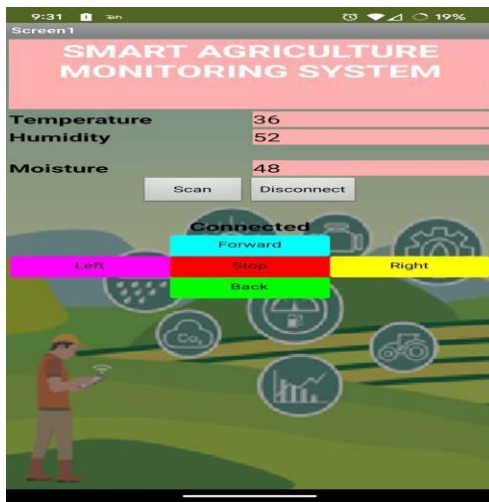

Figure 2. Mobile application for proposed system

Temperature, Humidity, & Moisture of the soil content. The system proposed in this paper is built in such a way that if the moisture content of the soil measured from the soil moisture sensor is below the determined threshold value an alarm buzzer is triggered and notification for the same is displayed on the app. Also, they will now be able to control the movement of the robotic car on which the system is fixed wirelessly through the mobile app. The mobile application is designed in such a way that it becomes easier for the user to control the robotic movements and at the same time receive real-time agricultural parameters displayed within the app. Now this data can be utilized further by the farmer to determine the best conditions and environment for increased agricultural production for each and every portion on the land used for farming which is stored on the cloud IoT platform Thing Speak IoT with all its current and previous historical data.

III. CIRCUIT DIAGRAM

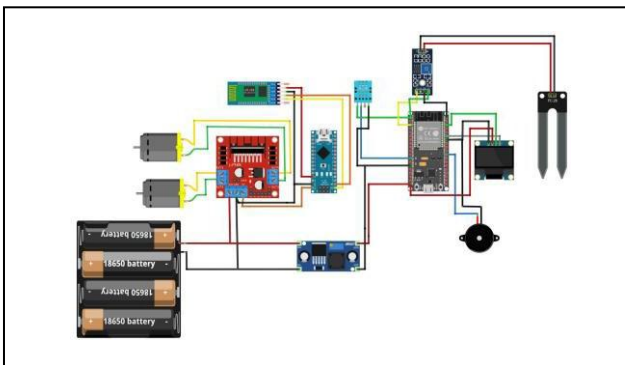

Figure 3. Circuit Diagram of IoT based Smart Agriculture Monitoring System

IV. WORKING

When the system is turned ON, powered by rechargeable Lithium-ion Batteries it powers Arduino nano and ESP32 microcontroller which initiates the controlling and sensing unit of the proposed system. [6][7] So, when this system is powered up the user would be able to connect with the system with the help of mobile application explicitly designed for the purpose through Bluetooth present in the system. User just have to turn ON the Bluetooth connectivity on their mobile device identify the system through its Bluetooth name under available devices and pair it with device using the correct password. Once the user is connected with Smart IoT system, authorized user will then have the access to the entire system [8]. The user will now get the real-time information and readings of various parameters affecting agricultural yield like

V. FLOWCHART

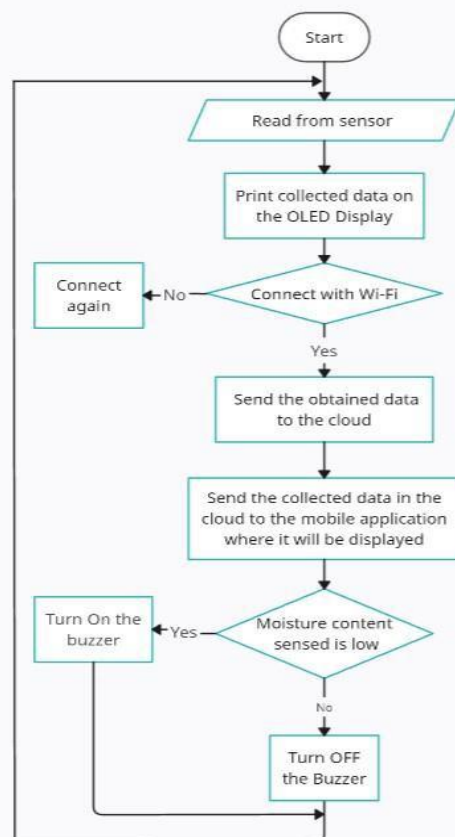

Figure 4. Flowchart for the sensing Unit

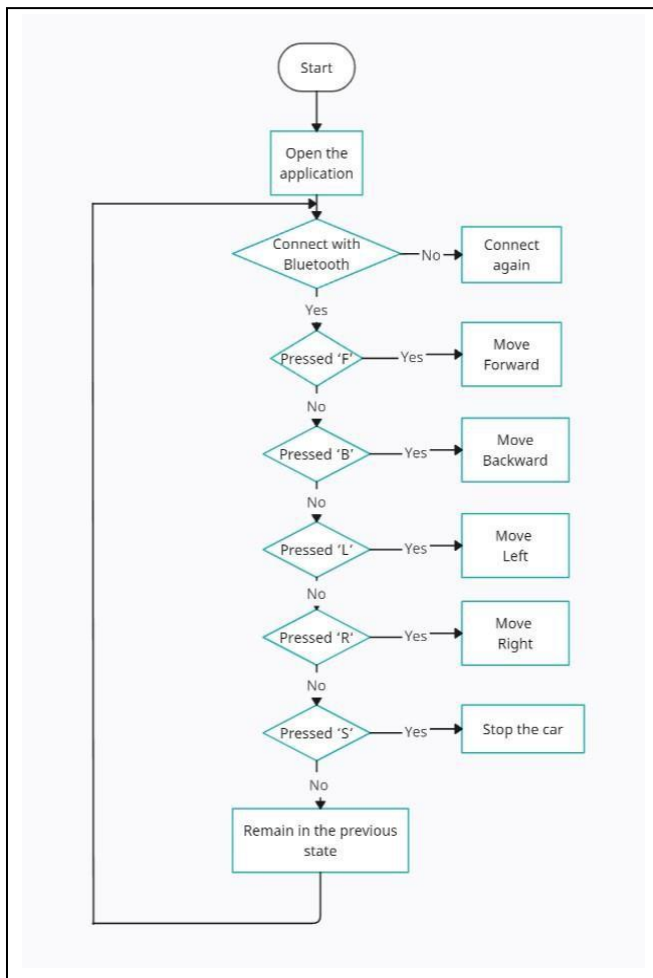

Figure 5. Flowchart for the controlling Unit

VI. RESULT AND DISCUSSION:

The system sends the data that is collected by the sensor to the IoT based platform Thing Speak IoT where all the previous data and current data is stored. This data is represented in the form of graph for each parameter as seen in the fig. which is further used for data-based analysis. The latest readings displayed on the Thing Speak IoT is then fetched in real time using thing speak API and these values are displayed on the mobile application as shown in the figure. The overall system helps the farmers/users in determining if the current conditions in the agricultural field for different produce is suitable or not without physically being there all the time which reduces labor effort and gives constant accurate results.

VII. CONCLUSION:

In summary, the proposed system is an innovative solution for addressing the challenges faced by the agriculture sector in India. By providing farmers with

real-time data and control over their crops, the system has the potential to increase crop yields, reduce resource waste, and improve environmental sustainability. The system's simplicity, affordability, and accessibility make it a valuable tool for farmers in rural areas of India,[8] where access to advanced agricultural technologies is often limited. The proposed system represents a significant step towards the development of smart and sustainable agriculture practices in India, and has the potential to significantly improve the livelihoods of farmers and the overall health of the agricultural sector.



Figure 6. Readings from Thing Speak IoT

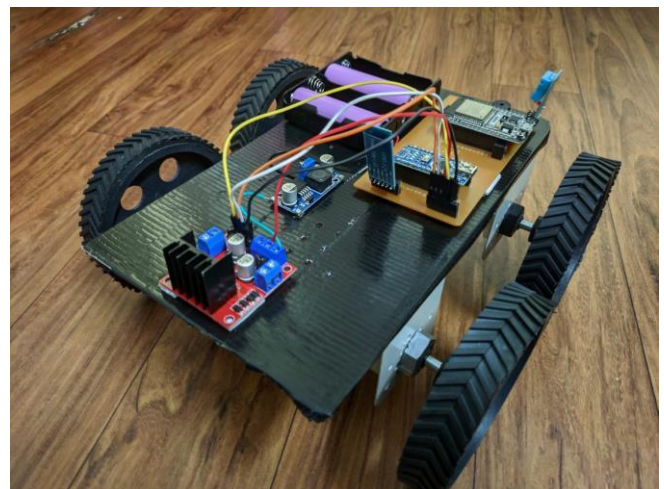

Figure 7. Project Prototype

REFERENCES

- [1] M, Manasa Reddy et al. "IoT based Crop Monitoring system for Smart Farming." 2021 6th International Conference on Communication and Electronics Systems (ICCES) (2021): 562-568.

- [2] Boobalan. J, Jacintha. V, J. Nagarajan, K. Thangayogesh and S. Tamilarasu, "An IOT based Agriculture Monitoring System," in International Conference on Communication and Signal Processing, April 3-5, 2018, India.
- [3] Islam, M. S. & Dey, G. K. (2019). Precision Agriculture: Renewable Energy Based Smart Crop Field Monitoring and Management System Using WSN via IoT. In 2019 International Conference on Sustainable Technologies for Industry 4.0 (STI), 24-25 December, Dhaka (pp. 1- 6). IEEE. doi: 10.1109/STI47608.2019.9029269.
- [4] R. Nageswara Rao and B. Sridhar, "IoT based smart crop-field monitoring and automation irrigation system," in Proceedings of the Second International Conference on Inventive Systems and Control (ICISC 2018), IEEE Xplore Compliant - Part Number:CFP18J06- ART, ISBN:978-1-5386-0807-4; DVD Part Number:CFP18J06DVD, ISBN:978-1-5386-0806-7.
- [5] G. Sushanth and S. Sujatha, "IoT Based Smart Agriculture System," 2018 International Conference on Advances in Computing, Communications and Informatics (ICACCI), Bangalore, India, 2018, pp. 1014-1019, doi: 10.1109/ICACCI.2018.8554686
- [6] Meti, A. G., Rayangoudra, P. N., Biradar, K. S., Kumar, V., Manoj, G. H., & Murthy, B. T. V. (2022). IoT and Solar Energy Based Multipurpose Agricultural Robot for Smart Farming. In 2022 IEEE International Conference on Data Science and Information System (ICDSIS) (pp. 1-6). IEEE. DOI: 10.1109/ICDSIS53466.2022.9753855
- [7] Akhund, T. Md. N. U., Hossain, Md. Rakib, Newaz, N. T., & Kaiser, M. Shamim. (2021). Low-Cost Smartphone- Controlled Remote Sensing IoT Robot. In M. S. Kaiser et al. (Eds.), Information and Communication Technology for Competitive Strategies (ICTCS 2020), Lecture Notes in Networks and Systems 190. Springer Nature Singapore Pte Ltd.
- [8] Prema, P. (2019). Smart Agriculture Monitoring System using IoT. International Journal of Pure & Applied Bioscience.