

# Design and Analysis of Cylindrical Arc Array Antenna

V. Venkata Jaya Sai<sup>1</sup>, P. Hema Kumar Reddy<sup>2</sup>, Y. Sruthilaya<sup>3</sup>, R. Balaji Naik<sup>4</sup>

<sup>1,2,3,4</sup> Students, Dept. of Electronics & Communication Engineering, R.V.R. & J.C. College of Engineering, Guntur, Andhra Pradesh, India

\*\*\*

**Abstract** – The microstrip patch antenna required for radio communications to be lightweight, ease in fabrication and smaller in size. The current plan aims to develop a microstrip antenna with a basic geometric shape that can provide improved directivity, gain, and high return loss. The article details the design and analysis of two microstrip antennas, one rectangular and the other square, both of which use microstrip line for feeding. In our Proposed project, the conformal arc array antenna is designed at 2.0 – 2.4 GHz which provides its usefulness in many wideband utilities within the range of S-band applications. Various parameters such as return loss, radiation pattern, gain, VSWR, directivity, efficiency can be determined. The optimized antenna design and results are presented by using CST (Computer Simulation Technology) software.

**Keywords:** Microstrip patch Antenna, Return loss, VSWR, directivity.

## 1. INTRODUCTION

An antenna refers to a metallic construction that can receive and/or transmit radio electromagnetic waves. These structures are available in a wide range of sizes and shapes, including small ones placed on roofs for television reception and larger ones that can capture signals from satellites located millions of miles away.

Planar antennas often have a limited range of frequencies they can operate on, especially when it comes to microstrip antennas. These types of antennas may not be very efficient at radiating signals and may have low gain. However, their performance can be improved by adding notches or using shorting pins in the radiating patch. Additionally, incorporating gaps between patches in planar antennas can enhance their gain. This is why quad patch antennas with several mid-sized patches are preferred over antennas with a single, large patch.

On the other hand, conformal antennas are a type of antenna that can overcome the limitations of both planar and circular antennas.

A conformal antenna or conformal array is a flat array antenna that is designed to fit a specific shape or mold, typically used in radiocommunication and avionics. This type of antenna can be molded to a prescribed shape, allowing it to be installed onto or incorporated within a curved surface, such as a flat or curved antenna on a curved surface. This

kind of antenna is made up of numerous individual antennas that are mounted onto or within the curved surface and function as a single antenna to transmit or receive radio waves. Conformal antennas were initially created in the 1980s as a way to incorporate avionics antennas into the curved surface of military aircraft to reduce aerodynamic drag, replacing traditional antenna designs that stick out from the surface of the aircraft. While conformal antennas are most commonly used in military aircraft and missiles, they are also utilized in some civilian aircraft, military ships, and land vehicles. Due to a reduction in the cost of processing technology, conformal antennas are being contemplated for use in civilian purposes, including train antennas, car radio antennas, and cellular base station antennas. The reason behind this is that these antennas occupy less space and can be incorporated into pre-existing objects, thus reducing their visual impact.

Conformal antennas belong to the category of phased array antennas. They consist of a multitude of identical small planar antenna elements, such as patch, horn, or dipole antennas, covering the surface. A phase shifter device is present at each antenna, which is controlled by a microprocessor. By regulating the phase of the feed current, the nondirectional radio waves produced by the separate antennas can be made to converge in front of the antenna through interference, generating a concentrated beam or beams of radio waves aimed in any desired direction. In a receiving antenna, the weak individual radio signals collected by each antenna element are combined in the appropriate phase to amplify signals originating from a specific direction. This allows the antenna to be sensitive to the signal from a specific station and to discard interfering signals originating from other directions.

An array antenna, also known as an antenna array, consists of numerous interconnected antennas that operate together as a unified unit for transmitting or receiving radio waves. These antennas, referred to as elements, are typically linked to a single receiver or transmitter through feedlines that provide power to the elements in a precise phase relationship. Each antenna emits radio waves that overlap and combine, resulting in constructive interference in desired directions, amplifying the radiated power, and destructive interference in other directions, decreasing the radiated power. When used for reception, the individual radio frequency currents from each antenna are combined in the receiver with the appropriate phase relationship to boost signals received from the desired directions and suppress

signals received from undesired directions. Advanced array antennas may include multiple transmitter or receiver modules, each linked to a distinct antenna element or cluster of elements.

A typical phased array consists of antenna elements arranged on a flat surface, whereas a conformal antenna has antenna elements mounted on a curved surface. To account for the varying path lengths of radio waves caused by the location of individual antennas on the curved surface, phase shifters are used in conformal antennas. Conformal arrays are often restricted to high frequencies in the UHF or microwave range because the size of individual antenna elements must be small enough to fit, given that small antennas can only be utilized when the wavelength of the waves is small.

## 2. ANTENNA DESIGN AND ANALYSIS

To start designing a microstrip antenna, the first step is to select the appropriate operating frequency and substrate. It is important to choose a working frequency that is suitable for the intended use of the antenna, and to ensure that the antenna will operate within the desired frequency range. The working frequency in our design is picked to be 2 – 2.4 GHz, which is in S-band region. The subsequent stage in the antenna structuring is to pick appropriate substrate. The height and dielectric of the substrate steady relies upon the electromagnetic features of the antenna. The chosen material for the design is Rogers-RO 3003, which has high dielectric properties. This helps to decrease the size of the antenna since the dimensions are inversely related to the dielectric constant. The antenna is being fed using a microstrip feedline.

Rogers Corporation's RO3003 is a laminate made from PTFE that is filled with ceramic and suitable for RF and microwave applications up to 40 GHz. With a dielectric constant of 3 between 8-40 GHz, this laminate offers reliable plated through-hole connections, even in harsh thermal conditions.

The length, L, and width, W, of the antenna are found out by using the following equations.

### 2.1 DESIGNING EQUATIONS:

- Dielectric Constant ( $\epsilon_r$ ) i.e.,  $2.2 \leq \epsilon_r \leq 10$
- Height (h) i.e.,  $\lambda_0 \leq h \leq 0.05 \lambda_0$

Where  $\lambda_0$  = free space wavelength

- Width of microstrip patch antenna

$$W = \frac{c}{2f_r} \sqrt{\frac{2}{(\epsilon_r + 1)}}$$

Where, c = velocity of light

$f_r$  = Operating frequency

$\epsilon_r$  = Substrate dielectric constant

- Effective dielectric constant

$$\epsilon_{reff} = \frac{\epsilon_r + 1}{2} + \frac{\epsilon_r - 1}{2} \left(1 + 12(h/w)\right)^{-1/2}$$

- Length of patch,  $L = L_{eff} - 2\Delta L$

Where,

$$L = \frac{c}{2f_r \sqrt{\epsilon_{reff}}} - 2\Delta L$$

$$\Delta L = 0.412 * h \left( \frac{(\epsilon_{reff} + 0.3) \left(\frac{W}{h} + 0.264\right)}{(\epsilon_{reff} - 0.258) \left(\frac{W}{h} + 0.8\right)} \right)$$

For practical length,  $0.3333\lambda_0 < L < 0.5\lambda_0$

Here,  $\epsilon_r$  is the dielectric constant of the substrate. The chosen substrate, is Rogers-RO 3003 with  $\epsilon_r$  of 3, and the working frequency, f, is taken to be 2 – 2.4 GHz.

The effective length is subjected to the correction factor,  $\Delta L$ , and this correction factor is found to be nearly 0.07.

### 2.2 Proposed Antenna Design:

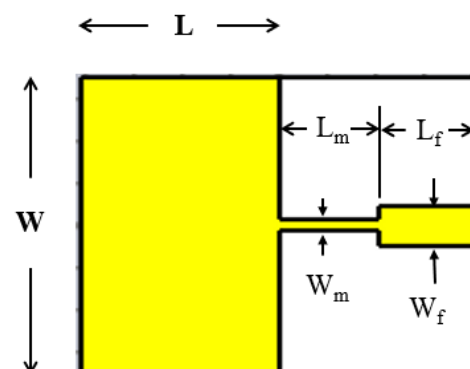
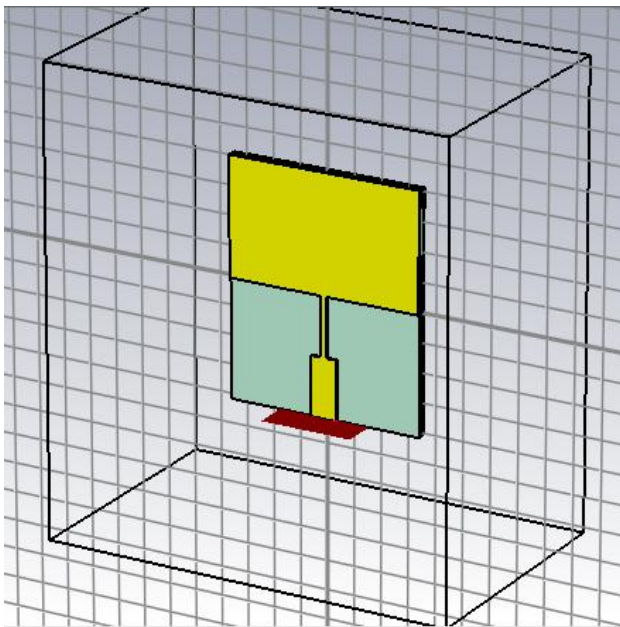


Fig a: The geometry of the antenna in microstrip technology

L	W	L <sub>m</sub>	L <sub>f</sub>	W <sub>m</sub>	W <sub>f</sub>
41mm	35mm	20.5mm	20.5mm	1.2mm	4.8mm

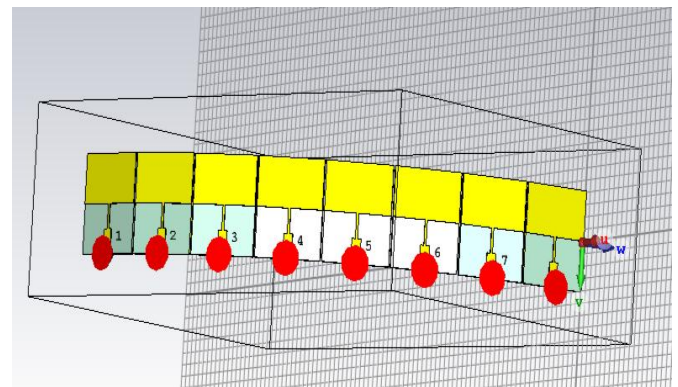
**Table-1:** Design Values of Single Patch Antenna



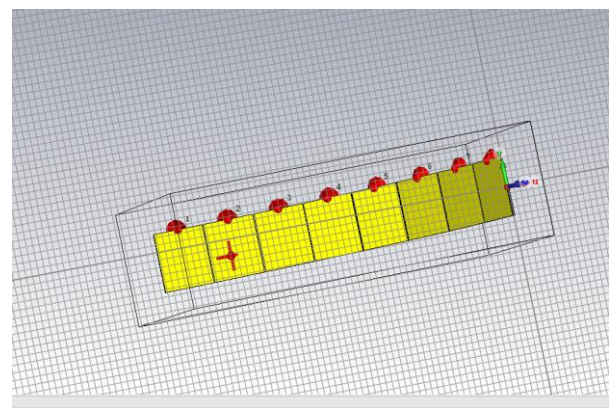
**Fig b:** Design of Single patch Antenna using CST

Similarly, by using the above design the Cylindrical Arc antenna array patch in Fig: b (1) and b (2) is shown. In these we are using 8 single patch antennas which are conformed into cylindrical arc shape as shown in Fig: b (1) and b (2).

Using an array of antennas can result in a more concentrated directionality, meaning a narrower stream of radio waves with higher gain, compared to using a single antenna element. As the quantity of antennas in an array grows, both the gain and the narrowness of the beam tend to increase. Large arrays, like those found in military phased array radars, may contain thousands of individual antennas. Arrays serve various purposes, including boosting gain, providing path diversity (also known as MIMO) for better communication reliability, eliminating interference from particular directions, electronically steering the radio beam to various directions, and facilitating radio direction finding (RDF).



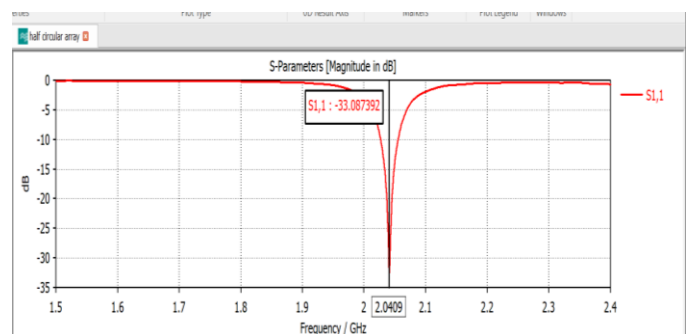
**Fig b (1):** Front view of Conformal Arc patch antenna array



**Fig b (2):** Back view of Conformal Arc patch antenna array

### 3. VALIDATION OF RESULTS

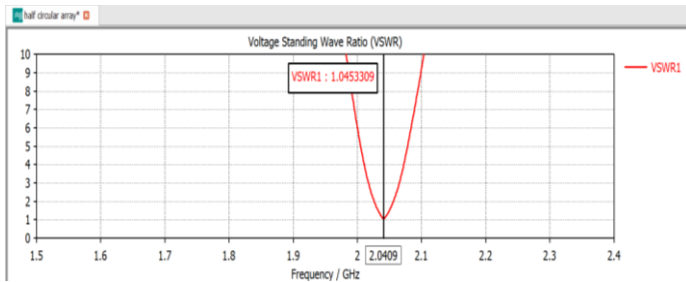
The proposed antenna has been designed and simulation is done using CST software. It has been observed that as the substrate height is increase from 1.5 mm to 2 mm, the antenna resonant at 2.04 GHz. With substrate height 2 mm, maximum return loss of -33.08 dB is obtained which is shown in Fig c.



**Fig c:** S-Parameters

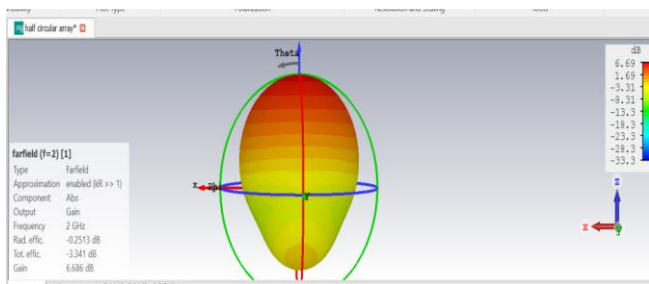
For the Single patch antenna, we had obtained the value of VSWR of 1.04 as shown in Fig d.



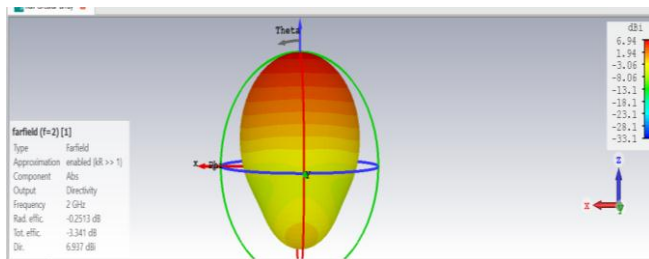


**Fig d:** Voltage Standing Wave Ratio (VSWR)

Figure e and f shows the Directivity of 6.937 dBi and gain of 6.686 dBi for the Microstrip single patch antenna.

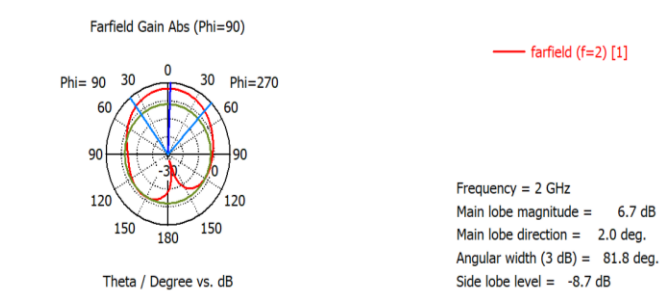


**Fig e:** Gain = 6.686 dBi



**Fig f:** Directivity = 6.937 dBi

Far field pattern of Microstrip Single patch Antenna as shown below.

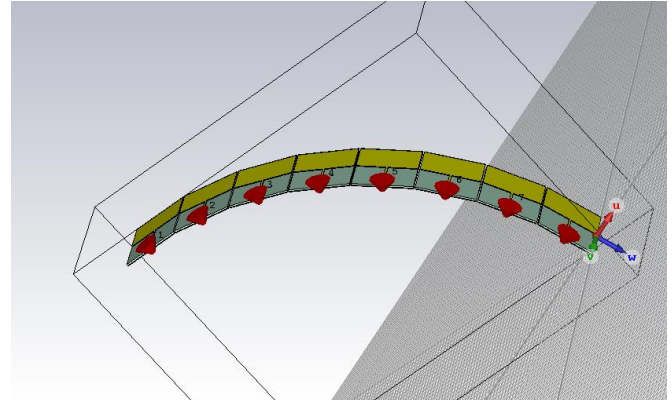


**Fig g:** Far field pattern

#### 4. VALIDATION OF RESULTS FOR CYLINDRICAL ARC ANTENNA

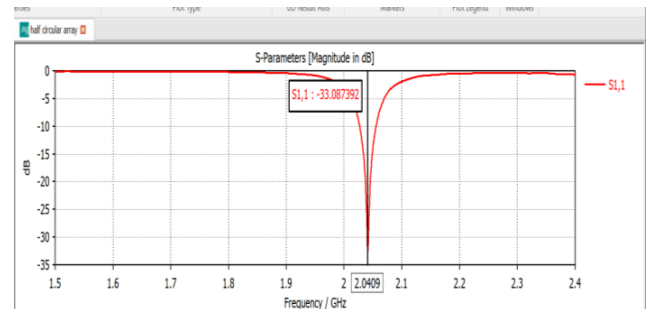
The proposed antenna has been designed and simulation is done using CST software. From Fig h, there are 8 single

patch antenna elements which are combinedly formed as an array. All these elements are used in order to increase the gain and directivity.



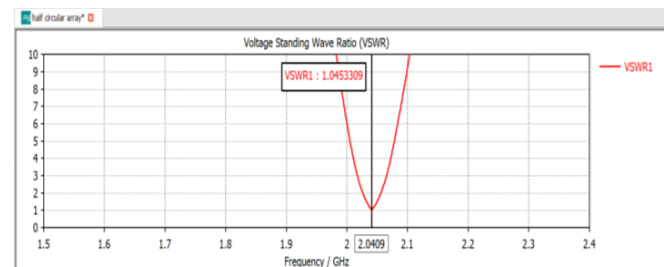
**Fig h:** Cylindrical Arc Array Antenna

Results of Cylindrical Arc array Antenna is shown in below figures.



**Fig i:** S-Parameters

For the Single patch antenna, we had obtained the value of VSWR of 1.04 as shown in Fig j.



**Fig j:** Voltage Standing Wave Ratio (VSWR)

Figure k and l shows the Directivity of 6.937 dBi and gain of 6.686 dBi for the Microstrip single patch antenna.

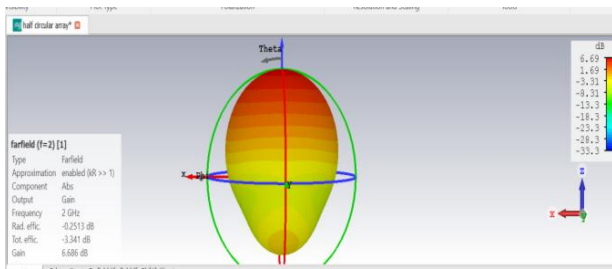


Fig k: Gain = 6.686 dBi

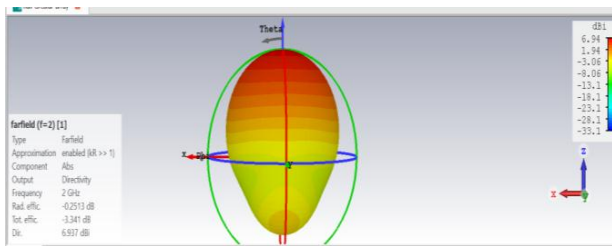


Fig l: Directivity = 6.937 dBi

Far field pattern of Conformal Arc array antenna as shown below.

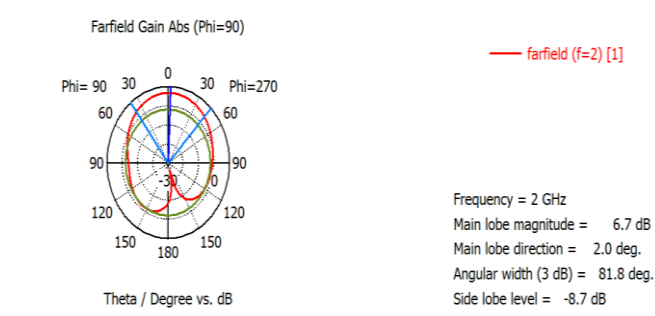


Fig g: Far field pattern

## 5. CONCLUSION

The proposed microstrip patch antenna with stub feedline exhibits a high reflection coefficient of -33.08 dB with the substrate height of 2 mm. This is validating in all the designed aspects of the different structure of the antenna. The broadening of the antenna is attained by the proper impedance matching by stub feedline at the source point of the antenna. In this we have improved various parameters like VSWR, gain, return loss, directivity which might be useful for many communication applications.

## REFERENCES

[1] Raj Gaurav Mishra, R. K. Chourasia, Amit Kumar Shrivastava, International Journal of Innovative Technology and Exploring Engineering (IJITEE) ISSN: 2278-3075, Volume-8 Issue-7 May, 2019

[2] Lars and P. Petrik, Conformal Array Antenna Theory and Design, John Wiley & Sons, Hoboken, NJ, USA, 2006.

[3] Research Article Conformal Array Pattern Synthesis and Activated Elements Selection Strategy Based on PSO GSA Algorithm.

[4] Bahare Mohamadzade, Roy B. V. B. Simorangkir, Raheel M. Hashmi and Ali Lalbakhsh: "A Conformal Ultrawideband Antenna with Monopole-Like Radiation Patterns", IEEE Transactions on Antennas and Propagation, Volume: 68, Issue: 8, August 2020, Page no: 6383 - 6388.

[5] Giacomo Muntoni, Giorgio Montisci, Giovanni A. Casula, Francesco P. Chietera, Andrea Michel, Riccardo Colella, Luca Catarinucci, Giuseppe Mazzarella: "A Curved 3D-Printed Microstrip Patch Antenna Layout for Bandwidth Enhancement and Size Reduction", IEEE Antennas and Wireless Propagation Letters, Volume: 19, Issue: 7, July 2020, Page no: 1118 - 1122.

[6] R. Garg, P. Bhartia, I. Bahl and A. Ittipiboon, "Microstrip Antenna Design Handbook", Artech House, 2001.

[7] J. Lars and P. Patrik, Conformal Array Antenna Theory and Design, John Wiley & Sons, Hoboken, NJ, USA, 2006.

[8] O. M. Bucci, G. D. Elia, and G. Romito, "Power synthesis of conformal arrays by a generalized projection method," IEE Proceedings—Microwaves, Antennas and Propagation, vol. 142, no. 6, pp. 467–471, 1995.

[9] L. I. Vaskelainen, "Iterative least-squares synthesis methods for conformal array antennas with optimized polarization and frequency properties," IEEE Transactions on Antennas and Propagation, vol. 45, no. 7, pp. 1179–1185, 1997

[10] C. A. Balanis, "Antenna Theory – Analysis and Design", Wiley-Interscience, 2012.