

# Design of Self Regulating Pressure Valve using Transient Finite Element Analysis

Ganesh Taware<sup>1</sup>

<sup>3</sup>Lecturer, Dept. of Mechanical Engineering, Sharadchandra Pawar Institute of Technology Someshwar, Maharashtra, India

\*\*\*

**Abstract** - Most flow applications require regulating the flow of liquid, and usually the parameter of concern is the pressure. This paper explains design of self-regulating pressure valve by using transient finite element analysis. This paper focuses on the exchange of liquid between two chambers, where in it is required that flow be shut off when a certain pressure is reached. Electronic valves are available, however the intent of this design paper is have a total mechanical system, which has an in built response mechanism.

**Key Words:** Pressure valve design, Transient analysis, FEA, spring design, Stress etc

## 1. INTRODUCTION

In fluid flow application basically hydraulic and pneumatic valves are being used. These are of pressure controlled type and flow controlled type. Considering the vast growth, the pressure control valves plays vital role and explored for large scale applications. With the development of self-regulated bi- metallic valve [1] the next focus has been to develop a pressure valve which is equally robust. The main idea remains same, safety of the system, and prevention of vessel bursting due to pressure overload. Traditional safety valves work on the outlet side, wherein if a particular open, resulting in a pressure relief and prevention of bursting [3]. Electronically actuated pressure regulating valves are used to regulate inflow into vessel, wherein if pressure is reached to critical pressure, it fully or partially shut off flow of liquid. However if the gas is toxic, pressure is reached the valves burst release should be the last option. The idea is then to regulate inflow into the vessel, once a critical pressure is reached. To tackle this problem, idea of self-regulating pressure valve controlled by using purely mechanical actuation is put forward.

## 2. PROBLEM STATEMENT

To design self-regulating pressure Valve; which can regulate the pressure in the system within given specified limit with regards to an axial and bending load by the flowing liquid'. Multiple objectives include material finalization, thickness requirement for restrictor plate, and stiffness finalization for spring. The geometric dimension should be such that, self-weight should be the operational

parameter for the valve. Further FEA techniques are used to test this design to study the stress patterns and to ensure a durable design. Key constraints in designing the valve are geometrical parameters as well as operating parameters.

**Table -1:** Input Condition and Operating Parameters

	Inlet loop	Feedback loop
Size	R35mm	R25mm
Inlet/Feedback Pressure	0.23mpa(Full shut off) 0.21mpa(90% shut off) 0.10mpa(Full open)	
Feedback error	N	Less than 3%

Operating Temperature: 22 - 350 °C

In this valve, a spring loaded restrictor plate will be used. Restrictor plate (obstruction) will be so calibrated that it will connect to the vessel where pressure is to be regulated. The pressure P, inside the vessel will push the obstruction against the spring load. In self-regulating pressure valve, the obstructer will have a combined load of bending due to the flow, plus the load of the springs and pressure. This will be a transient phenomenon and will need careful FEA for determining life of the valve.

## 3. FINITE ELEMENT ANALYSIS

### 3.1 Element selection, Model Geometry and Meshing

Element selection has been done in such a way that significant reduction is achieved in solution time; also higher order elements are chosen to attain high accuracy level. After the type of element has been selected, the model geometry must be considered. There are several prime considerations in evaluating the geometry. In addition to the necessity to accurately represent the actual geometry component of the valve, one must consider the loading and

support (boundary) conditions and the mesh to be employed.

### 3.2 Design Procedure

Design by Analysis (DBA) approach is used to finalize geometric parameters of valve component. In this approach initially some dimensions are assumed and analysis is done with necessary boundary conditions. Further to optimize the dimensions such that maximum stresses are within allowable limits.

### 3.3 Design of Restrictor Plate

#### Material Specifications

Generic Name SA 512 Grade 70

Chemical composition Carbon (0.27)

Manganese (0.85-1.20)

Phosphorous (0.025)

Sulphur (0.025)

Silicon (0.13-0.46)

Young's Modulus (E) 200GPa

Poisons Ratio 0.3

Density 7850 kg/cm<sup>3</sup>

For design of a regulating valve, the most important component is the plate that will actually restrict and regulate the fluid flow. The plate will be subjected to a bending load as well as axial load. The basic design problem of a regulating valve, which is set to close at a particular pressure, and which will reduce the flow as the set pressure is being reached as illustrated in figure 1. Under this concept as the plate pushes to close the flow, the net area subjected to fluid pressure will increase. Based on specification given for inlet and feedback loop basic plate dimensions are decided.

At beginning of analysis, plate thickness is taken as 1mm. But at this thickness maximum stresses and deformation developed in the plate due to bending load is beyond the allowable stress. Now plate thickness is gradually increased from 2mm to 4mm. Due to increase in the plate thickness maximum stress values are reduced and are less than the yield stress. It is not feasible to increase the plate thickness beyond 4mm. Hence it is decided that to make support arrangement in the valve jacket such that restrictor plate is supported by grooves in the jacket. Sliding contact is maintained between plate and support. The equivalent maximum stress developed is 8.3453 MPa which is less than yield stress i.e. 160 MPa. Therefore plate is safe against bending load.

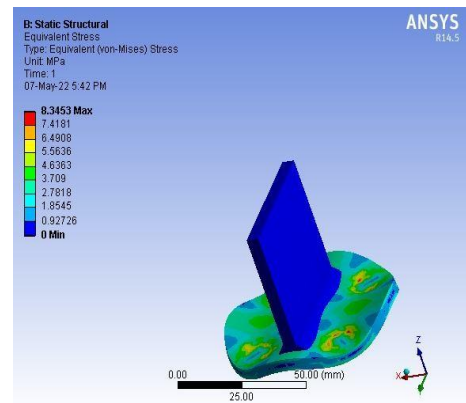

Fig -1: Solution plots

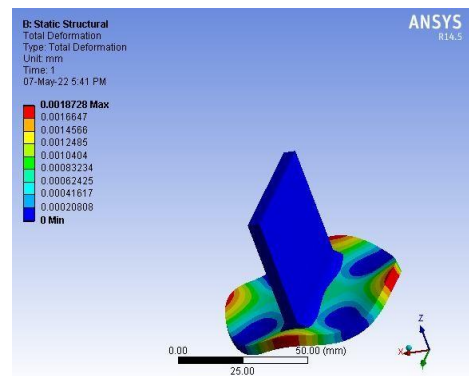

Fig -2: Deformation plots

### 3.4 Design of Spring

Free length,  $L_f = 78\text{mm}$

Maximum expected deflection  $\delta_{\max} = 55\text{ mm}$

$L_f = \text{Solid length} + \text{Max. Compression} + \text{Clearance between adjacent coils}$  In actual practice clash allowance is taken 15% of maximum deflection

After solving, we get Solid length = 6mm.

These allowance for accommodate solid length of the spring is also considered while finalizing the restrictor plate dimension Force exerted on down face of the plate is given by,

$F = \text{Maximum pressure} \times \text{cross area}$

$$F = 0.23 \text{ MPa} \times \pi \times 0.035 \times 0.035 = 884.69$$

No. of spring = 4

Force per spring = 221.7 N

Spring stiffness is given by, 4.02 N/mm

This is required stiffness for functionality of the valve closure. Thus Standard spring is selected from the spring manual which is having same stiffness and free length. For the analysis purpose four cylinders are modeled with above mentioned spring stiffness which acts as a spring while doing analysis.

### 3.5 Design of valve socket and flange

Next important task is to design socket which is required to give supportive arrangement for the movement of the restrictor plate. The main function of socket is giving support to the plate. Dimension of the socket are decided based on dimension of the restrictor plate such that it can maintain sliding contact with surface. Two grooves are provided on sliding contact surface of the socket to support restrictor plate against bending load. Design of flange also important task while designing valve. Dimension of flange can be decided according to ASME Code. The design of flange is decided according to inside diameter of the pipe.

### 3.6 Design of pipe

Pipes are used for carrying various fluids like steam, water, different types of chemicals, gases, with or without pressure from one place to another place. Cast iron, Steel, Brass are the materials generally used for pipes in engineering practice. The design of pipe involves the determination of inside diameter of the pipe and its wall thickness. At initial stage of design Cast Iron material has been chosen, but as the value of 'C' is 9 for cast-iron, which results in increasing the thickness therefore it has been replaced by Structural Steel [4]. The inside diameters of pipes have been decided. The thickness of the wall (t) in order to withstand the internal fluid pressure is obtained by thin cylindrical formula.

By considering this entire dimension, the Gradual Flow Reducing Valve has been modeled. Final assembly is as shown in fig.3

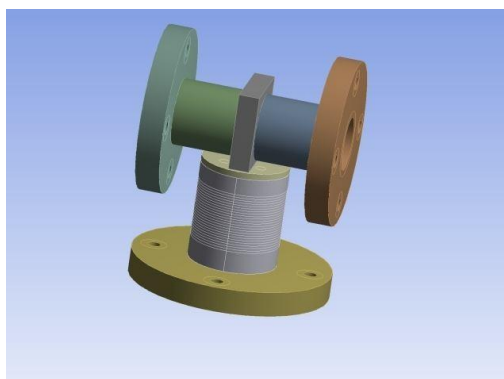

Fig -3: Assembly of valve

To check the safety of entire assembly it is important to carry out steady state structural analysis. All the valve components designed in previous sections are modeled in ANSYS workbench. Also meshing of the assembly model is done with SOLID 186 element. Further details of analysis are given below,

Discipline	Structural
Analysis type	Steady state
Type of Element	SOLID 186
Number of sub steps	10
Number of Nodes	103941
Number of elements	40034

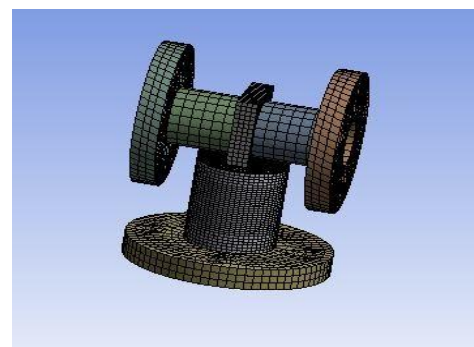

Fig -4: Meshed model of valve

Both the faces of restrictor plate are exposed to the bending and axial load of 0.23 MPa. Inner surface of the pipes are subjected to maximum operating pressure. Bonded and sliding contacts are maintained at desired locations.

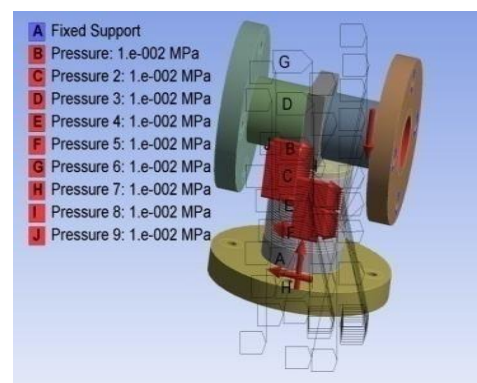

Fig -5: Boundary conditions

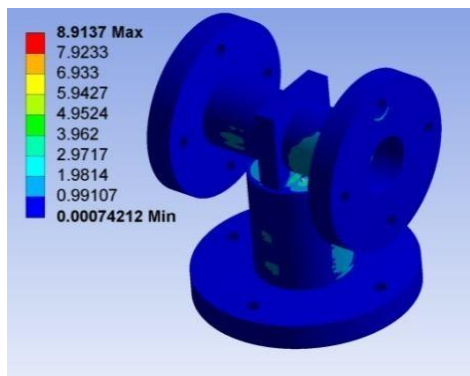

Fig -6: Stress Solution plot of Steady state structural Analysis

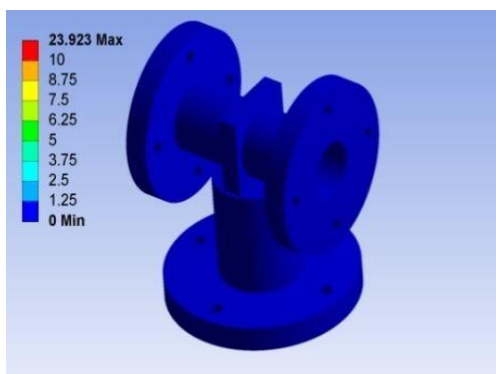

Fig -7: Deformation Solution plot of Steady state structural Analysis

After imposing all the necessary boundary condition are imposed and corresponding Von mises stresses and deformation are observed. Equivalent stress obtained is 55.27MPa which is within the permissible limit also deformation is also sufficient enough for valve performance. Hence design is safe.

### 3.7 Transient Structural Analysis of valve

Transient analysis is generally used to determine the dynamic response of a structure under the action of any general time-dependent loads. It is used to determine the time-varying displacements, stresses, strains, and forces in a structure as it responds to any transient loads [5]. Here performance of the gradual flow reducing valve, i.e. lifting movement of restrictor plate is very slow. Restrictor Plate area is exposing to the fluid flow instantaneously as the feedback loop pressure increases. Hence it is essential to examine time dependent dynamic response of the valve.

After doing static structural analysis, transient structural analysis is done on the entire valve body. In static analysis load is applied in one step. But for transient analysis load is applied in 78 steps. Each step is of 1mm. Further details of analysis are given below,

Analysis type Transient  
 Type of Element SOLID 186  
 Number of load steps 78  
 Number of sub steps 10  
 Number of Nodes 156096  
 Number of elements 37949

Plate area exposing to the fluid flow at inlet side is divided into 78 load steps. As pressure at feedback side is increases plate moves upward against the spring force and hence at particular time “t” each step is experiencing different pressure. As time advances successive load step is applied on plate. Hence plate is exposed to increasing fluid pressure. Graph below shows how time dependent pressure input given for each load steps. Pressure is applied on plate surface as well as inner wall of pipe. Table 2 indicates the details of transient structural analysis. The sub steps in ANSYS analysis are 100 by default. But it has been reduced to 10 in order to reduce the time of analysis. In this transient analysis maximum load (i.e. pressure) is divided into 78 load steps as tabulated below. And this time dependent pressure magnitudes are applied as boundary conditions for analysis.

Table -2: Transient Pressure Input

	Load steps					
	1	2	3	.....	77	78
1	0.002	0	0	.....	0	0
2	0.005	0.005	0	.....	0	0
3	0.008	0.008	0.008	.....	0	0
4	0.011	0.011	0.011	.....	0	0
				.....		
				.....		
77	0.227	0.227	0.2270	.....	0.22700	0
78	0.229	0.229	0.2299	.....	0.22999	0.2299

Transient loads are applied on restrictor plate faces and inner surface of the pipe. Equivalent stresses and deformation are observed. Stresses obtained are within the permissible limits hence design is safe.

Table -3: Results

Solutions	Values
Equivalent Stress	8.9137
Deformation	23.923
Equivalent Stress for plate	5.4432

#### 4. CONCLUSION

Restrictor plate thickness is finalized with Design by Analysis approach such that it can well account for the Bending as well as Axial loading. The theoretical design of spring stiffness were designed based on the sliding distance calculation, however they ignored parameters such as the friction of sliding of valve and bending pressure exerted on the valve also reduces the sliding distance of valve. The dimensions of the constituent part of the self-regulating pressure valve were finalized. Transient structural analysis is done over valve assembly. This analysis shows maximum stress developed is 8.9137 Mpa which is within the permissible safety limit.

#### REFERENCES

- [1] Kagadi M, Tembhare G, Patil V, Shelke S, "Optimization of self-Activating Bi-Metallic Valve using Thermo-Structural Coupled FEA", 2012.
- [2] Peng Z-F, Sun C-G, Yuan R-B, Zhang P, "CFD analysis of main valve flow field and structural optimization for double nozzle flapper servo valve", *Procedia Engineering* 2012; 31: 115-121.
- [3] Hindurao DV, Chavan DS. Optimization of 16" Plug Valve Body Using FEA and Experimental Stress Analysis Method", 2012.
- [4] Wu H, Zhong Z, Benseddiq N, Imad A, 'Numerical solution of crack shape of the thermo-mechanical loaded valve', *Engineering Failure Analysis* 2011; 18: 1487-1495.
- [5] Yang, Zhang Z, Liu M, Hu J. Numerical Simulation of Fluid Flow inside the Valve, *Procedia Engineering* 2011; 23:543-550.
- [6] Mohan R, Schudel BR, Desai AV, Yearsley JD, Apblett C.A, Kenis PJA, "Design consideration for elastomeric normally closed micro fluidic valves, *Sensors and Actuators*", 2011; B 160: 1216 1223.