

Robotic Tactile Sensor Probe used for Contour plotting of Weld Joint in Seam Tracking System

Swati Omprakash Upadhyay¹

¹ BE, Department of Mechanical Engineering, Savitribai Phule Pune University, Pune, Maharashtra, India

Abstract - Welding is a process of joining two similar or dissimilar metals and it requires edge preparation to achieve full welding penetration. Generally, the edge preparation is done manually and many errors occur on the edge due to the handling of the workpieces. These errors in the edge preparation can make the welding process tedious and inaccurate and an arduous task for the welding torch to track the trajectory path to be welded. To accomplish welding operations correctly even in this inappropriate condition, industries are turning towards Robotic Welding Methods. One such Robotic welding system that comes under these methods is Seam Tracker, which is a system that plots contour points by tracking the welding seam line. This trajectory path helps in guiding the torch even in deflections due to deformities on the edge. Many industries are currently using a seam tracker which uses a laser sensor to track the seam line accurately, but due to its high cost and the presence of noise in the output data obtained, it doesn't serve as a good investment for many small-scale industries. Therefore, industries are turning towards Seam Tracker which uses tactile sensors and is a more affordable welding system. A Probe tip is used as a sensor that rides over the weld joint and defines contour points for the welding torch. These contour points help in determining the correct trajectory for the welding torch. In this paper, the Sensor system of Seam trackers and the design and analysis of the probe tips of the tactile seam tracking system are elaborated.

Key Words: Tactile Probe, Seam tracker, Optical Seam tracker, Robotic welding system, Probe tip, sensors, position sensors, Touch sensors.

1. INTRODUCTION

In this era of technology, manufacturing organizations need to boost their performance and upgrade their machines. To improve human productivity and product quality and to speed up the response to market demands, the method of Computer Integrated Manufacturing has been introduced. In CIM, Robots play a significant role in automation by performing a repetitive task which enhances the quality of manufacturing. [1] Robots can only function properly if the events are expected. However, when a robot experiences an unexpected event, it either halts the process or continues in the wrong direction. Both the operation reaction of the robot is not favourable, Hence a Robot should be provided with adequate information that is not provided in the teach-in phase. For this extraordinary information, it should be able to sense the environment outside it with the help of sensors. The usage of sensors in the robot depends on the application of the robot in the industry. A variety of sensors are available in modern-day automation and robotic technologies. These sensors are characterized into two types; Proprioceptive and Exteroceptive robot sensors. Proprioceptive sensors are used to obtain information on the inner state of the robot like joint angles, angular velocity, position and orientation of the tool centre points, forces and torque on the manipulator links. The output data of the proprioceptive sensors is the input to the motor control system which receives its set points from the main control system. On the other hand, Exteroceptive sensors are used to analyze the environment of the robot or a manufacturing system. These sensors include Binary sensors, Scalar sensors, and Image sensors. Binary sensors include microswitches and reed switches, they provide information based on which the operation can be interrupted, started, or finished. Another type of electroreceptive sensor is the scalar sensor which is used for the acquisition of metric information such as relative position, linear and angular velocity, acceleration, pressure, gripping force, optical properties, thermal properties, and magnetic properties. In Robotics, Optical, Acoustic, and tactile Imaging is of major practical importance. Tactile and Acoustic sensors prove to be less expensive and hence, are used in many small-scale industries. Optical Imaging is majorly used in industries because it provides high-quality images by using a CCD (charge-coupled device) camera.

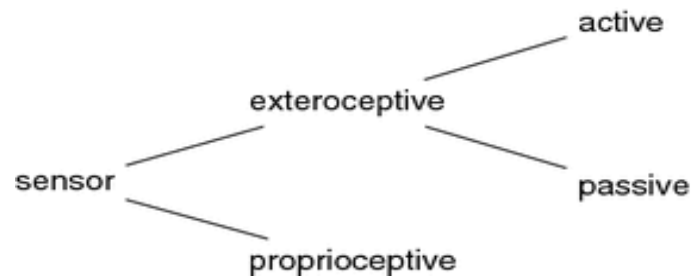

Figure 1. Category of Sensors

There has been much advancement in manufacturing technologies where a human worker is replaced with a welding robot since robots produce more efficient and consistent welds with less error. Welding is one of the significant operations of almost all manufacturing processes that resulted in numerous innovations in welding technology. Many welding operations need to be done in a hazardous environment where manual welding can put the welder's life at risk. In addition to this, many critical components need to be welded which requires very high focus and more time to be done. [2] [3]. Therefore, Mechanical Robots and motorized hardware play a major role to provide highly profitable production rates. Robotic welding leads to an increase in weld quality, adaptability, and a comfortable workspace. For many defects like weld gaps, improper surface finish, improper fitting of a workpiece, and in-process defects like thermal deformities due to welding and change in gaps, it is important to build a system that can inspect the defect and take corrective action. Generally, "Teach and Playback" welding robots were used to guide the torch along the weld seam path, another method is workpieces can be categorized according to their welding parameters, and considering these parameters different automated welding machines can be developed for each category. These robot systems were not suitable for changeable or varying welding conditions and many types of errors occurred such as pre-matching errors, assembly errors, and thermal deformation errors.

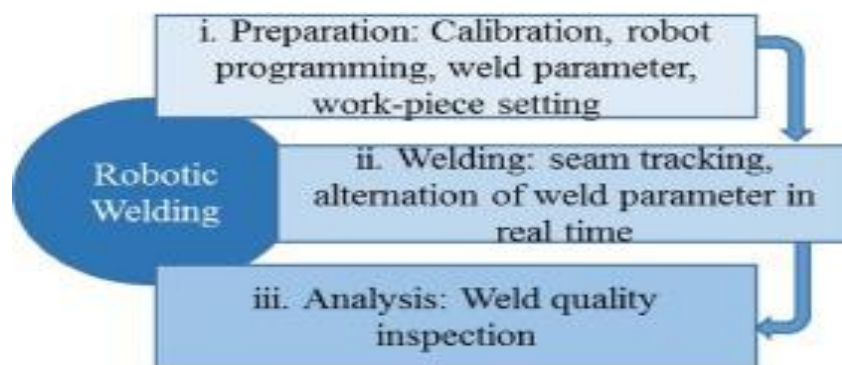

Figure 2. Steps in robotic welding

To track the weld accurately, it is necessary to obtain detailed information about the weld, such as the width, depth, and centerline of the weld. All these problems can be resolved by using a sensor for seam tracking and weld inspection. The addition of sensors in the automated welding operation transforms the robot into an intelligent robot that can recognize various issues and coordinate with sensors to enhance the efficiency of the system. These intelligent robots work wonders in welding operations, eliminating the difficulties for the human welder. For a variety of welding operations different robotic systems are designed and developed and more research is being done.

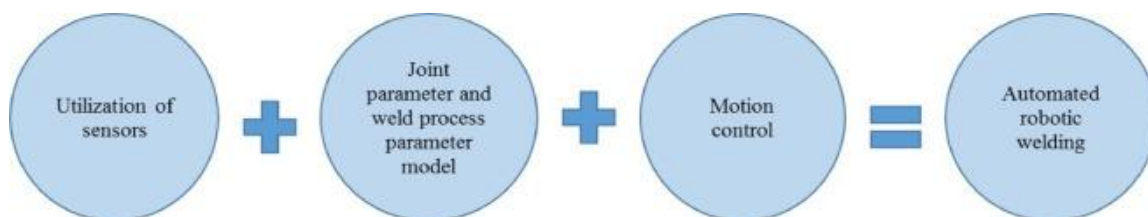

Figure 3. Aspects of Robotic welding

1.1 Seam Tracker

One such welding robotic technology that is widely used in automated welding operations in industries all over the world is Seam Tracker. This System improves the weld quality by tracking the accurate seam position by feeding the information to the controller and providing a precise trajectory path to the welding torch. Seam Tracker consists of two main processes as follows: a) Sensing Mechanism
b) Controlling System

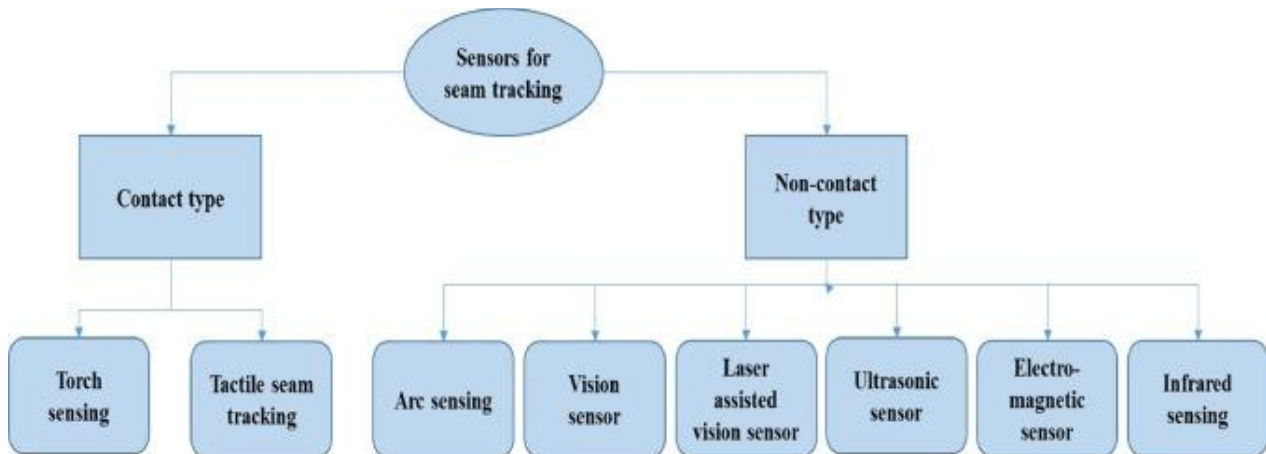

Figure 4. Types of sensors used for Seam tracking

An accurate contour plotting can be obtained for the trajectory of the path only if these two systems work in cooperation. Figure 5 shows a Seam tracking system using a Laser sensor as an instance to explain the basic components of the Seam tracker. The Sensing Mechanism Consists of a single sensor or an arrangement of position sensors like a Capacitive displacement sensor, Eddy-current sensor, Hall effect sensor, Inductive sensor, Laser Doppler vibrometer (optical), Linear variable differential transformer (LVDT), Photodiode array, Piezo-electric transducer (piezo-electric). These Sensor systems track the curvature of the weld seam joint and the data of the curvature like depth, width and the centerline of the weld joint is sent to the control unit. The control unit consists of the motor drives, PLC, connecting cables, and power supplies. The control unit responds to the deflections that are sensed by the sensors of each axis and corrective actions are performed accordingly.

Laser Seam Tracker for Welding Robots

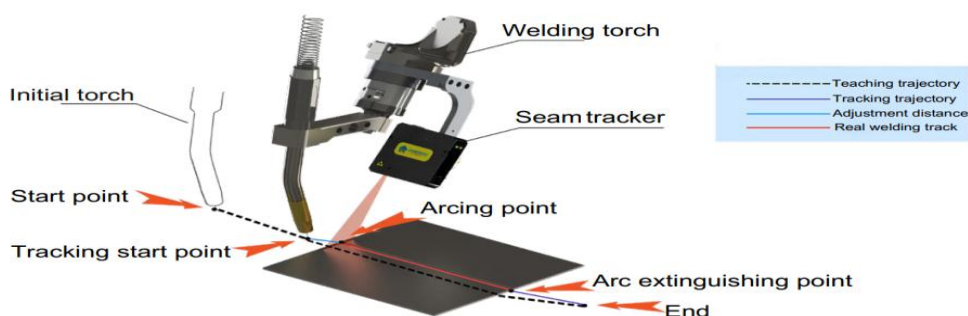

Figure 5. Seam Tracking System using Laser sensor

The seam tracking has been evolving over several years:

1. First Generation: Two-pass welding system was used, where the weld seam was tracked by the sensor in the first pass and the torch was operated to weld the seam line in the second pass.

2. Second Generation: This generation of Seam Trackers used the real-time scanning technique, where the tracking of the seam line of the joint and welding torch were operated simultaneously.

3. Third Generation: This generation of seam trackers also used Real-time Tracking with the addition of obtaining Information about variations in the weld seam.

Other methods by which seam tracking can be classified are the types of sensors used or the method used for tracking.

2. OPTICAL SEAM TRACKER

For many years, researchers have been experimenting with Seam trackers using a different variety of sensors to get an accurate and uniform weld by tracking the weld seam line accurately [4] [5]. Optical sensors have proven to be very efficient, where a CCD camera is used to capture an image and the data required for guiding the welding torch is extracted from it. In this paper [6], due to the difficulty in detecting the weld pool position during the arc welding process, the Kalman filter method was proposed where the welding images from the CCD camera are analyzed and the centroid of the weld pool images is extracted as the eigenvector of the weld position. This centroid represents the weld position relative to the welding torch. This method also helps in detecting the centroid measurements that are not consistent with previously taken data of centroid measurement and the desired weld trajectory measurement, hence it turns out to be very precise in detecting the weld position. [7] However, the algorithm detects the weld seam position from the two-dimensional image plane was not accurate, which thereupon made the system very complicated and time-consuming. Weld parameters like weld groove depth, weld gap, and detailed shape condition were difficult to extract. To resolve this issue, researchers suggested utilizing the laser sensor along with a CCD camera. A Laser Optical sensor consists of three main components as follows; laser diode, CCD camera, and filter. The CCD camera and laser are kept at some angle to capture the projection of the laser on the workpiece properly. The captured data is sent to the controller unit. A control unit then analyses the data and defines a trajectory for the welding torch. Once the trajectory is planned by the controller, the welding torch is allowed to follow the path of the trajectory. After numerous tests and trials, Optical seam tracking technology proved to be very efficient and accurate. Consequently, many large-scale industries are using this automation technology to boost their production rate and manufacture parts with uniform weldments.

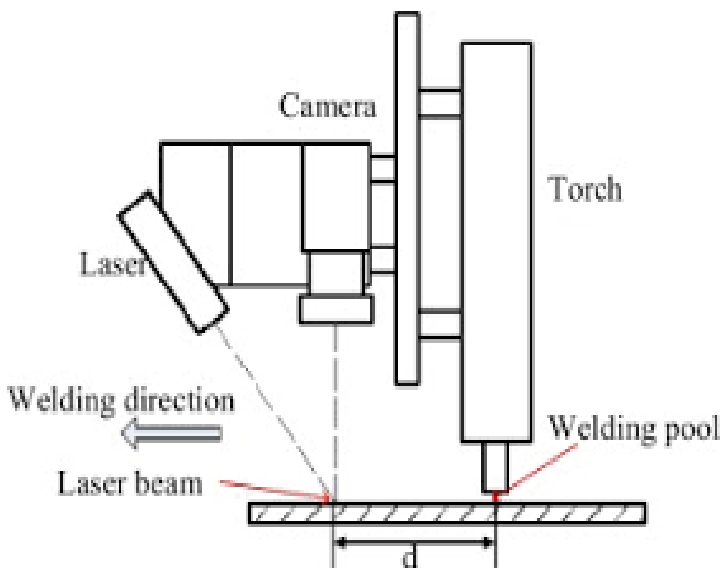

Figure 6. The figure shows an optical Seam Tracking System

Figure 7. Optical sensing Machine

2.1 Controller design

The data obtained from image processing are then sent to the control unit of the seam tracking system to guide the welding torch along the seam weld trajectory. There have been many innovations taking place in the controller design to align the torch with the weld seam line accurately. The author in [8], proposed the control design where the robot was

guided by the laser stripe sensor to the seam path trajectory. To remove errors, a control mechanism using a PLC to control a stepper was designed by the author [9]. After conducting several experiments the author [10] proposed a PID (Proportional-Integral-Derivative) controller in the control unit of the laser seam tracker, where offset value and rectifying voltage are taken into consideration as input and output.

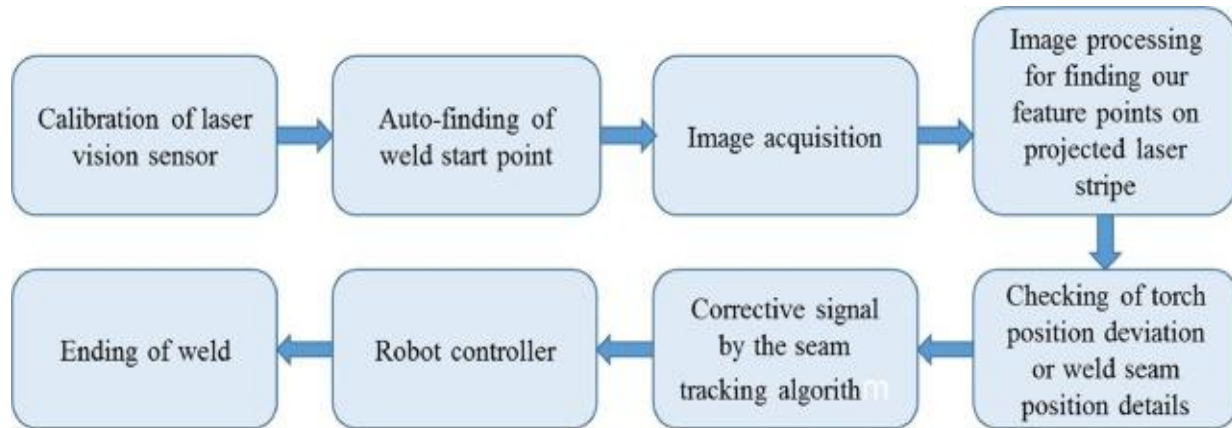

Figure 8. Method of Seam tracking by Vision laser sensor

2.2 Advantages of Optical (Laser) sensor

1. Tracking is very reliable
2. High speed can be achieved
3. Tracking is not affected by Weld settings
4. Functions of the welding are adaptable: Speed and Weld settings

2.3 Disadvantages of Optical (Laser) sensor

1. The depth of the V-Joint of the shiny metal like aluminium cannot be determined
2. High Complexity
3. High Cost
4. Training on the system is required
5. The sensor is mounted on the Torch, which leads to the restriction to the joint access
6. Outside light interference can alter the performance as well as the results obtained

Although the Optical sensor has many advantages, this system cannot be used by small-scale industries because of high capital investment and is difficult to replace, as an inappropriate data setting might cause severe loss to the industry and its production. In addition to the high cost, shiny metals like Aluminium cannot be welded using Laser or Optical sensor technology. The data fetched by the controller can also get affected by the external light, which results in inaccurate results. It has been observed during the experiments that the image acquisition was affected by the arc and spatter during the welding process. Mota et al [11], showed that the effects of arc and spatter can be eliminated by using High power illumination lasers and optical filters. But the high brightness of the high-power laser can cause damage to the person operating it and can also get overexposed to the camera. Therefore, it becomes difficult to locate the seam feature point from the unclear image is one of the issues. [12] Author Yong Zou proposed a CCAN-based welding image method to solve a problem of interference caused by arc and spatter in welding seam technology. This method helped in preventing the drift phenomenon in the welding seam tracking. This method also enhances the stability of tracking systems which improves welding accuracy. The author Y. Zou the paper [13] shows a new method based on the passive light vision technique, where the image is captured by a CCD camera. To obtain the deviation between the weld groove and weld torch a narrowband filter is used. The noise is eliminated by the median filter and wavelet transform and the details of the image are obtained. This deviation of the welding torch from the centreline of the groove can be used in the Seam tracking of robots. In the paper [14] the author brings up the semi-autonomous robotic weld system, in which the vision sensor calculates the robot weld trajectory and weld parameters by using the inbuilt data which is collected by scanning by vision sensor in 3D CAD drawing. This approach reduces the need for programming robotic weld parameters for each part. The data can be refined by using the robot teach pendant after transferring the data to the control unit. A precise and uniform

weld seam is obtained which increases the productivity of the robotic system. In this paper [15] The laser seam tracking method is introduced categorizing it into 4 steps as follows:

- 1) Detection of the initial and the endpoints
- 2) Detection of the edge of the weld
- 3) Measurement of the width of the joint
- 4) Determining the welding path concerning the position of the welding robot

[15] The noise in the data is eliminated by the filtering mechanism and The result obtained by using all these 4 steps is very satisfactory, reducing the errors by precise position and average deviation up to 38.38% and 41.71% respectively.

To have a uniform weld throughout the trajectory acquired from the contour points on the joint, the data obtained should be errorless. To circumvent these complications, a Tactile sensing technology has come forth to make this technique more reliable.

3. TACTILE SEAM TRACKER

Tactile Seam Tracking Technology acts as an alternative solution by replacing the laser-based sensor with a fully automated mechanical sensor system. Similar to the Optical Seam Tracking System, Tactile sensors consist of two main subsystems namely Sensing Mechanism and Control Unit. Instead of the Laser sensor used in Optical Seam Tracker, a Tactile sensor is used which rides a probe tip and at the same time it also detects the deviation at the edge it touches, simultaneously sending the data of the contour plotting of the Trajectory to the control unit. Hence, this process is a closed-loop system. A signal from the control unit is then sent to the Cross slides. Cross slides consist of slides in X, Y, and Z coordinates, whose motions are controlled by servo and stepper motors. The Cross slide arranges the slides in all three directions to sync with the Trajectory path defined by the contour plotting done by the tactile sensor. As per the data obtained by contour plotting, a welding torch is sent to follow the plotted trajectory and hence a uniform and even weld is obtained. It was analyzed that mechanical sensors might provide similar seam tracking with accuracy and precision as that laser sensors. These mechanical sensors are not just economical but also quite compatible with industries at all levels of production.

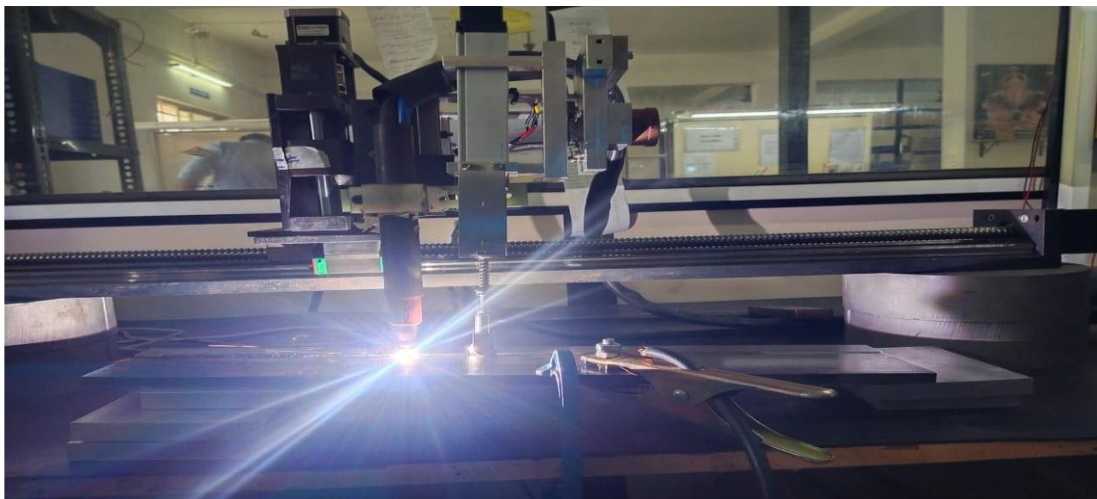

Figure 9. Tactile Seam Tracker with a Cross slide

3.1 Selection of sensors

The tactile seam tracking technique uses a probe that senses a deflection and aligns the welding torch at the centre of the weld seam. The deflections in the probe are in all three-dimensional coordinates X, Y and Z. To detect the deflection in all three directions, an arrangement of mechanical position sensors are used. These sensors can be a Linear potentiometer, an encoder, LVDT, etc. Refer to [section 1](#) of the paper.

3.2 Selection of Cross slides

The selection criteria for the cross slide are as follows:

- 1) Dimension of the selected joint
- 2) Determining the stroke length
- 3) Payload requirement

The standard slides that are available in the market are:

- 1) ST40
The payload capacity of 18kg
Stroke length of 8cm*8cm
- 2) ST250
The payload capacity of 113kg
Stroke length of 13*13
- 3) ST450
The payload capacity of 204kg
Stroke length of 25*25

The initial step in the selection criteria of the cross slide is to determine the dimensional range in which the joint of the component is to be welded. The dimensional range of the joint helps us to ascertain the minimum and maximum deflection that can take place. The approximate knowledge of deflection that might occur in the stroke length required for the cross slide can be anticipated. The next step is to determine the payload required. If the desired payload and stroke length is known, the legit cross slide is selected among the standard cross slides available in the market. [Figure 10](#) shows the cross slides for two directions.

3.3 Selection of motors

After the data from the sensing mechanism is transferred to the control unit, the Control unit adjusts the X, Y and Z slides of the cross slide to align the welding torch in the centre of the joint. This adjustment or the movement of the cross slide is done with the help of motors. Generally, the Servo motor and stepper motor are used. [Figure 11](#) shows the motors used to move the cross slides in Tactile Seam Tracker.

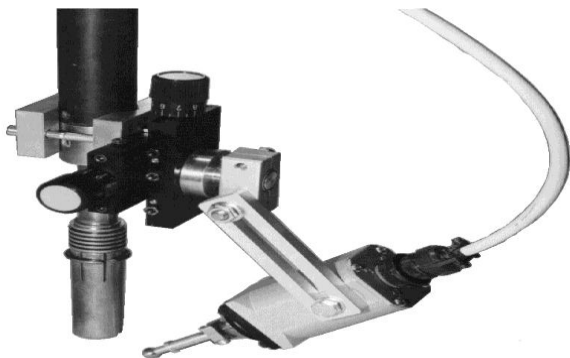

Figure 11. Motors used in a cross slide of Tactile Seam tracker

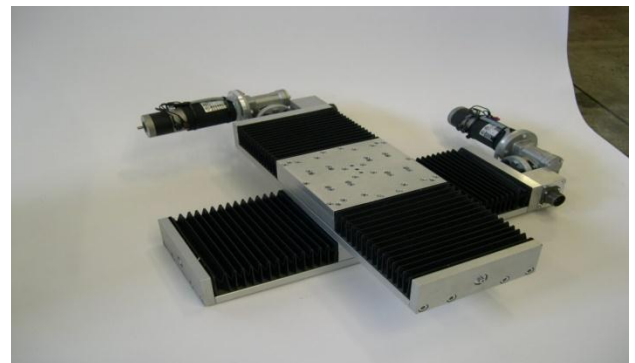

Figure 10. Cross slide with two-axis movement

3.4 Design and Analysis of probe

The paper aims to plot a contour and define a trajectory for a Tactile Seam tracking system to enable precise welding operation. During the operating conditions the probe goes through many deformations including static structural due to the loads on the components, frictional contact between the workpiece and the probe, and thermal deformation due to the welding temperature. The probe has to be strong enough to sustain the real-time deformation taking place while the welding operation. All these deformations may reduce the life of the probe, which might affect the overall performance of the machine system. To get precise real-time contour plotting, the deformations need to be minimized and the cross-

sectional dimension of the probe should be maintained. So, it is very important to design a probe that is more sustainable and has a good life expectancy. Therefore, an Analysis of the probe is done to analyze stresses, Deformation, Factors of safety, Equivalent stress, and Life, and accordingly, the design of the probe is modified.

3.4.1 Design parameters

A V groove of an expectable size of 8mm depth with a 30-degree angle is considered and a probe is designed as per its dimension. Both the probe and the joint are designed in the CAD software called CATIA and the analysis is performed on the CAE software called ANSYS. Numerous types of probes can be used for contour plotting but for this paper we are considering roller probes. The design of the roller probe will be modified after analyzing the results obtained from ANSYS and a suitable design will be chosen for the system.

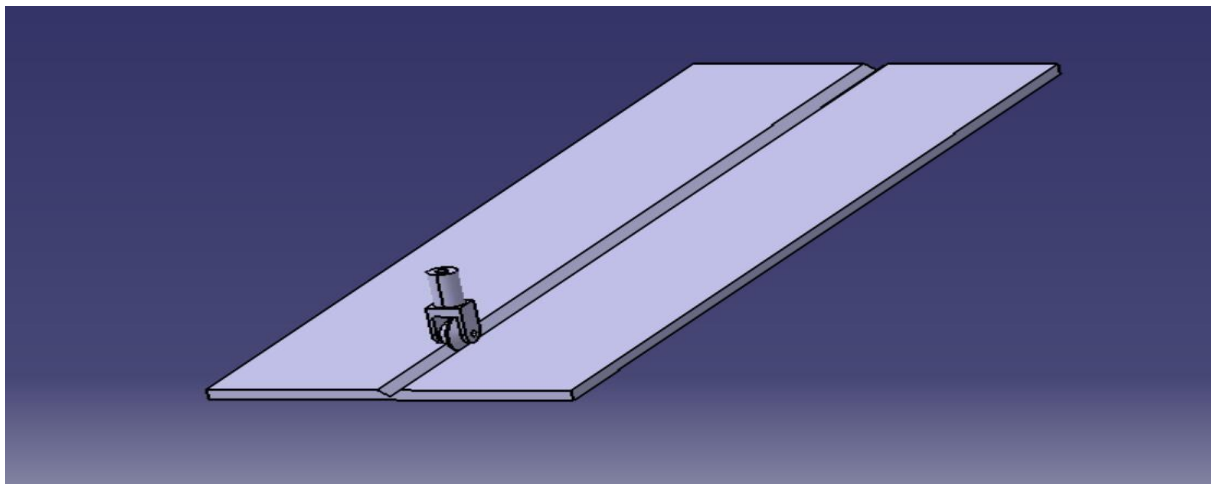

Figure 12. CAD model of V-groove and roller probe

3.4.2 Material Selection

After examining the hardness, thermal coefficient of Linear expansion and corrosion resistance, SS 431 was selected. SS 431 has its application in the manufacturing of bolts, shafts, pumps, propeller shafts and in laboratory appliances. The 400 series of stainless steels have higher carbon content, giving it a martensitic crystalline structure. This provides high strength and high wear resistance. The chemical and Mechanical properties of SS 431 are as follows:

Table1: Mechanical Composition of SS431

Tempering Temperature (°C)	Tensile strength (MPa)	Yield strength 0.2% Proof (MPa)	Elongation (% in 50mm)	Hardness Brinell (HB)	Impact Charpy V(J)
Annealed	862	655	20	285	-
204	1345	1055	20	388	50
316	1295	1035	19	375	53
427	1350	1080	19	388	#
538	1140	965	19	321	#
593	1015	770	20	293	64
650	960	695	20	277	84

Table 2: Chemical Composition of SS431

Grade		C	Mn	Si	P	S	Cr	Ni
431	min	-	-	-	-	-	15	1.25
	max	0.2 0	1	1	0.0 4	0.03	17	2.50

3.4.3 Meshing

After the geometry is generated, the 3D model of the probe meshes with an element size of 1mm. And the workpiece meshed with the element size of 2mm. Fine mesh is given to enhance the accuracy.

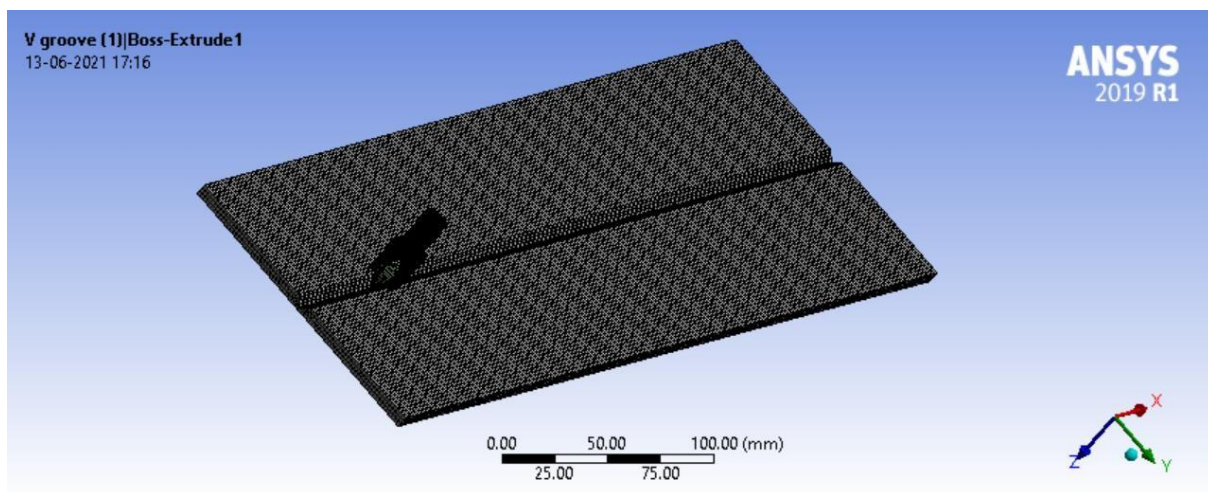

Figure13. The meshing of the Roller tip and Workpiece

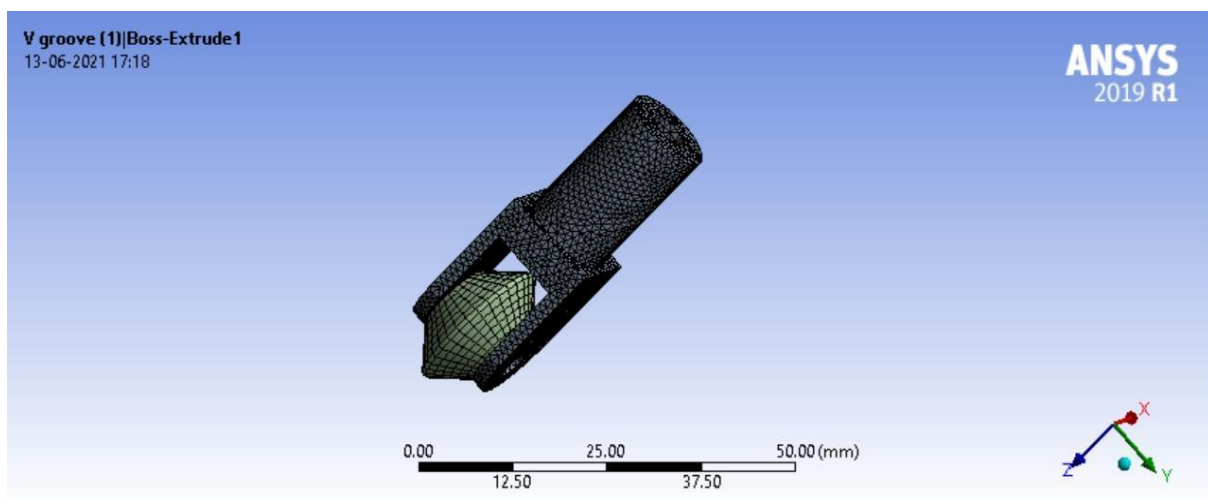

Figure 14. The meshing of the Probe tip

3.4.4 Steady State Thermal Analysis

During the welding conditions, thermal stresses are induced in the probe due to the contact between the probe and the workpiece and also due to the heat of the welding torch. These thermal stresses may cause the probe to deform, which might affect the sensing mechanism of the system. Data obtained from a deformed probe will not be accurate, hence it ll

affects the efficiency of the whole system. Steady-state thermal analysis shows the distribution of stress on the component and the design can be modified later

Temperature constraints:

After discussing the practical operating parameters with the industry from the domain of welding automation, the initial temperature of the workpiece is 200 °C and the conventional temperature on the probe is 22 °C. Figure 15 below shows the initial temperature constraints given to the probe and workpiece.

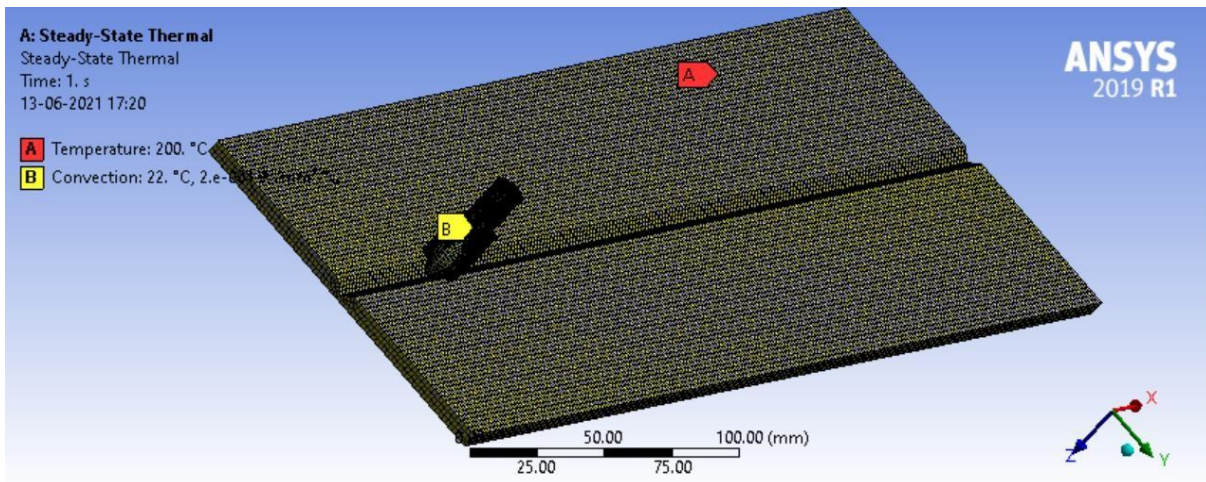

Figure 15. Temperature constraints

Results:

In Figure 16 below, it is observed that the maximum stress at the rolling section tip of the probe is due to thermal stress induced due to heat transfer during welding operation which is observed to be 182.67 C. The minimum temperature observed is 43.999 C. Maximum stress is at the roller section of the probe as the roller section is part of the probe which comes in contact with the workpiece under welding conditions, whereas the handle and upper section of the probe are way far away from the joint of the workpiece.

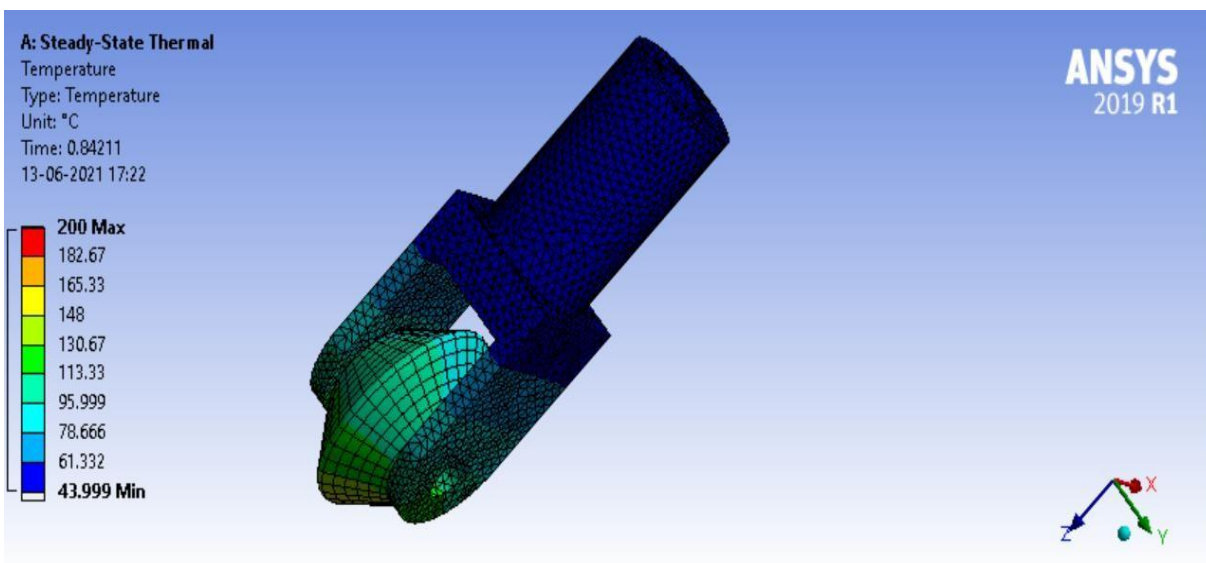

Figure 16. Temperature distribution of the probe

3.4.5 Static Structural analysis of the probe tip

To determine the deformation in the probe due to the loading conditions on the probe, static structural analysis was performed. The Probe is under small pressure which keeps it in contact with the V joint, so to find the stresses induced in the probe after the pressure is applied along with the Thermal Stresses, Static Structural Analysis is performed. The Static Structural analysis using the Fatigue tool also helps in predicting the Factor of Safety and Fatigue Life of the probe.

Loads and constraints:

Along with the thermal stresses, stresses due to pressure and loading conditions have to be considered. So, the pressure of 1.0053×10^{-4} MPa is applied at the two upper faces of the probe. The workpiece is fixed as the workpiece is clamped during the welding operating condition.

Results:

Figure 17 below shows the Total deformation of the probe is negligible concerning the dimension considered. But the maximum deformation is observed to be 1.2265 mm.

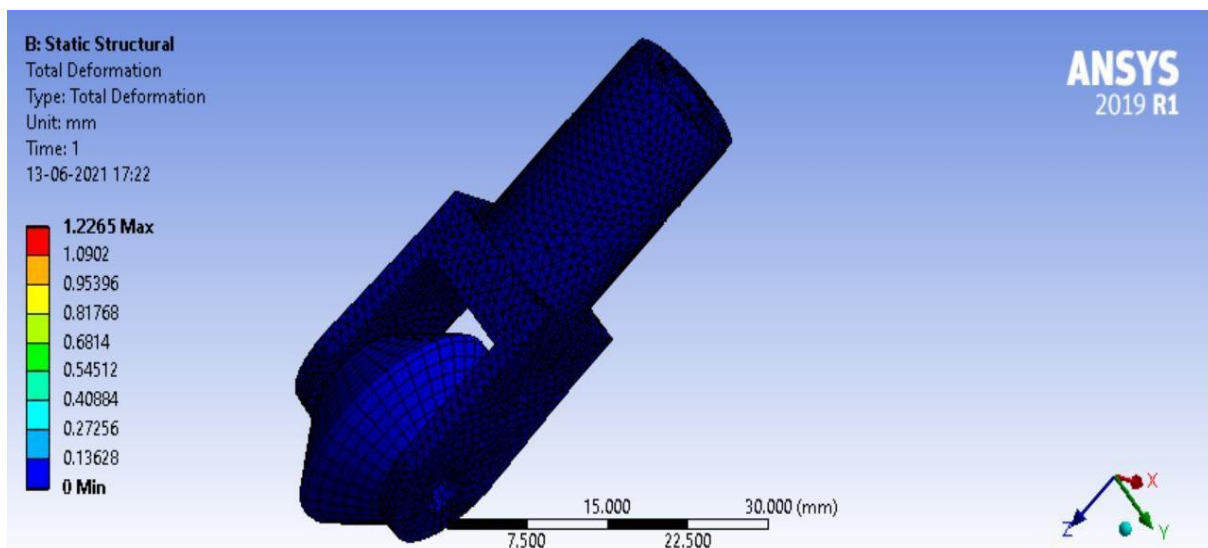

Figure 17. Total Deformation of the probe

Figure 18 below shows the equivalent stress in the probe, the maximum stress observed is the holding section of the probe and rolling contact between the probe and tip and weld joint. Due to the concentration of the force on the rolling contact between the roller and workpiece and also due to the load distribution at the holding section, maximum stress is induced at these two sections. The maximum stress is 151.83 MPa and the minimum stress is 16.874 MPa.

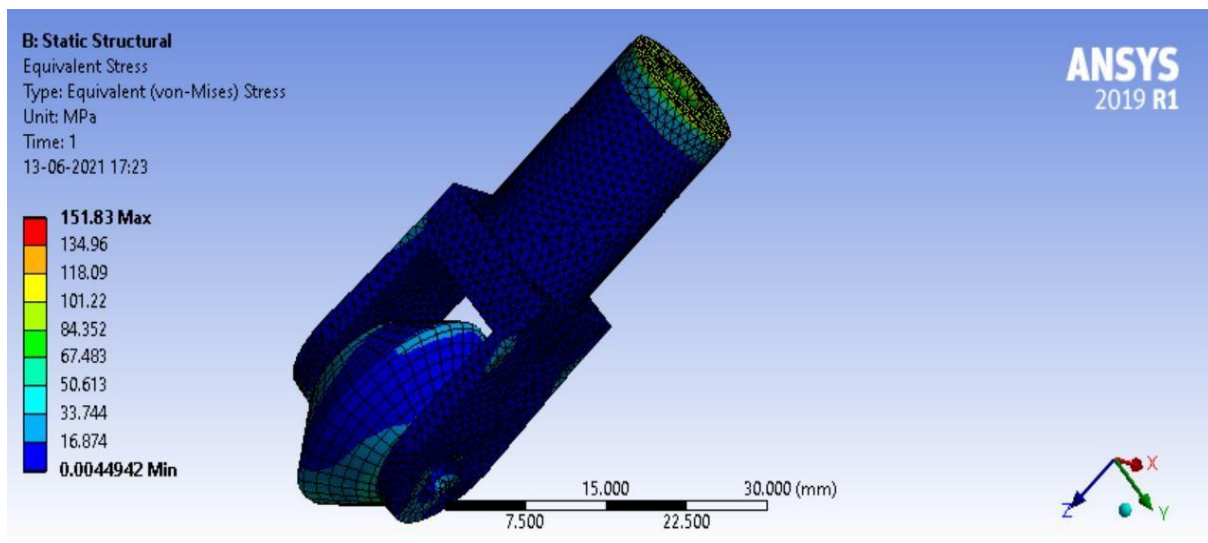

Figure 18. The distribution of equivalent stress

3.4.6 Factor of safety

The factor of safety is a significant parameter as it expresses how strong a system is and how strong the system needs to be. The factor of safety is the ratio of yield stress to working stress. If the factor of safety is greater than 1, then the design is considered to be safe.

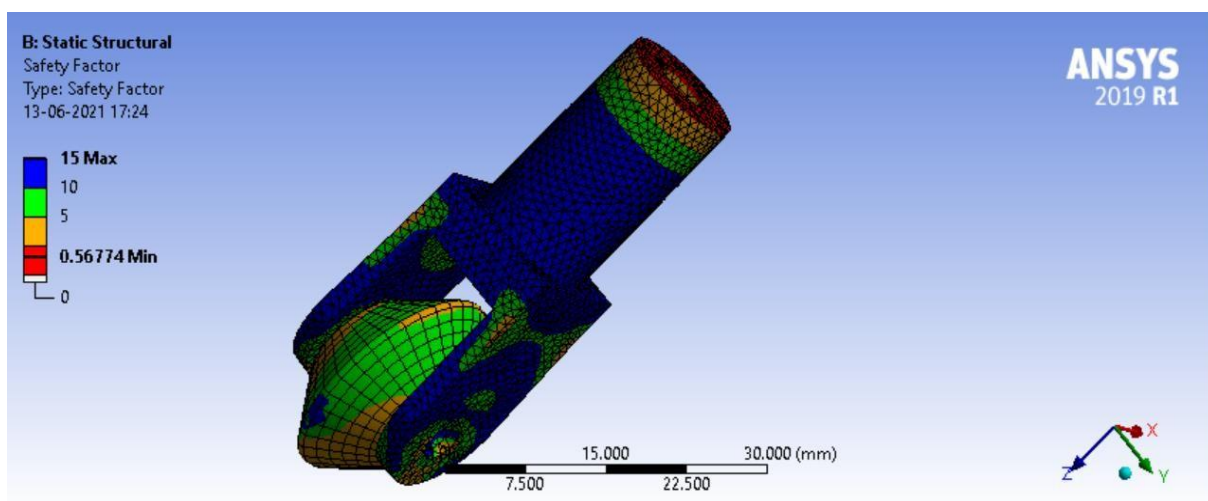

Figure 19. Factor of safety

From above [Figure 19](#), It is observed that the safety factor is less at the holding faces of the probe which is less than 1, which is considered unsafe for use. At all the other points of the probe, the safety factor is greater than 1. So, all the other points of the probe are safe.

3.4.7 Life of the Spherical probe

By doing fatigue analysis, the life of the spherical probe was found to be 15 years, if the probe worked for 2 hours in 1 cycle. [Figure 20](#) shows the study done to estimate the life of the probe.

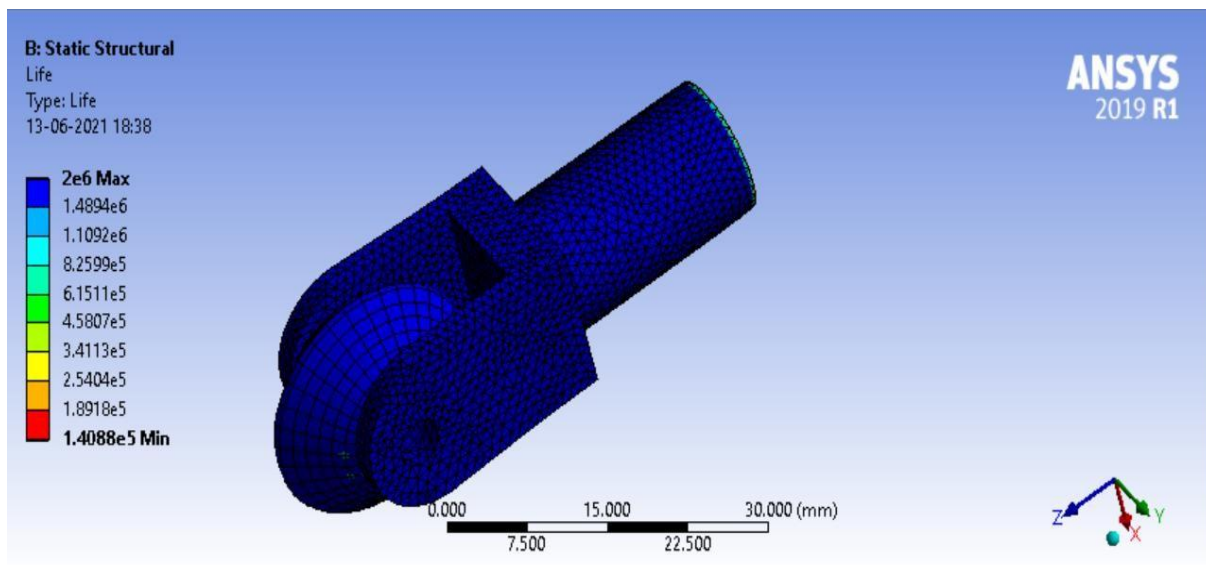

Figure 20. Life of the Roller Probe Tip

The Overall Result of the study done on roller probe:

From the data obtained from the Steady-state thermal analysis, it is observed that thermal stresses are induced at the rolling contact between the roller and workpiece. Also from data acquired from static structural analysis, it can be observed that the Factor of safety at the holding section of the probe is less than 1. which consequently makes it an unsafe design. To term a design as safe design the factor of safety of the component should be more than 1. To track the weld joint, the strength of the holding joint of the probe needs to be maximum, for the probe to track accurately. The probe acts as a component that senses and any deformation caused by the design failure in the holding section of the probe might alter the data transferred to the position sensors. To maintain the stiffness and tracking accuracy of the whole system, the design has to be safe. To resolve this problem, a new probe was designed, analysed and tested. The rolling contact of the probe was replaced by the point of contact of the spherical probe. To determine the safety factor, an analysis was done on ANSYS software.

3.5 Analysis of spherical probe

The results obtained after the analysis of the roller probe were not appropriate. Required results were not obtained even after many modifications in the design to minimize the stresses and to increase the factor of safety. To resolve these issues, a new probe was designed and verified by industry professionals under welding conditions. The roller probe was replaced by the spherical probe keeping the joint parameters the same. Analysis of the spherical probe was performed under the welding conditions and the results were satisfactory. The data from the design and analysis of the probe are mentioned below.

3.5.1 Design parameters

The 3D model is generated in the Solidworks software. A V groove of an expectable size of 8mm depth with a 30-degree angle is considered and a probe of 8mm diameter is designed. [Figure 21](#) shows the CAD Model of the V-groove and the sensing probe.

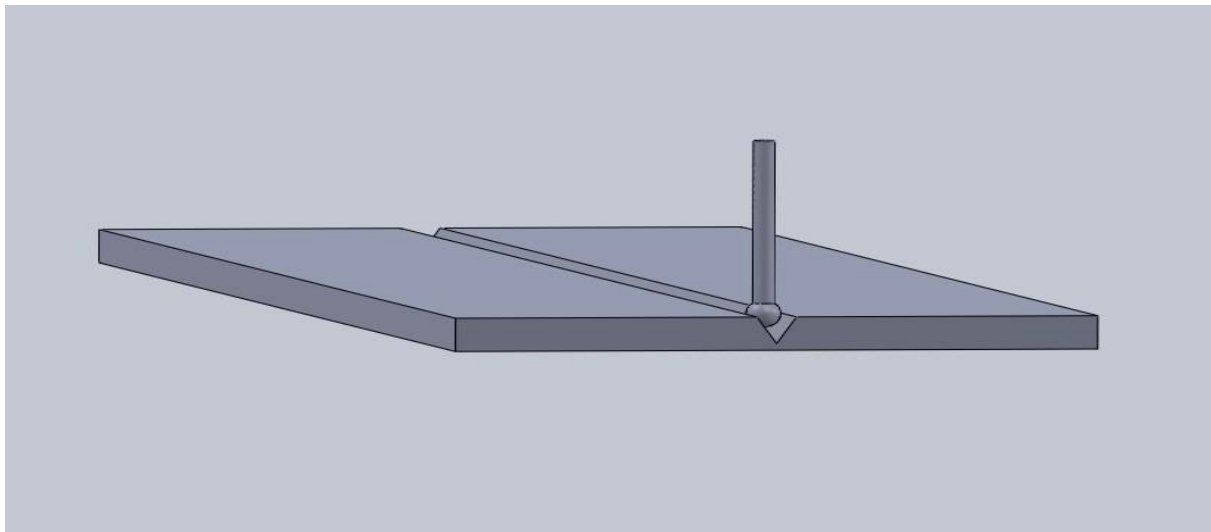

Figure 21. CAD Model of the V groove and the sensing probe

3.5.2 Material selection

After examining the hardness, thermal coefficient of Linear expansion and corrosion resistance, SS 431 was selected. SS 431 has its application in the manufacturing of bolts, shafts, pumps, propeller shafts and in laboratory appliances. The 400 series of stainless steels have higher carbon content, giving it a martensitic crystalline structure. This provides high strength and high wear resistance. The chemical and physical properties of SS 431 are as follows:

Table 3: Mechanical Composition of SS431

Tempering Temperature (°C)	Tensile strength (MPa)	Yield strength 0.2% Proof (MPa)	Elongation (% in 50mm)	Hardness Brinell (HB)	Impact Charpy V(J)
Annealed	862	655	20	285	-
204	1345	1055	20	388	50
316	1295	1035	19	375	53
427	1350	1080	19	388	#
538	1140	965	19	321	#
593	1015	770	20	293	64
650	960	695	20	277	84

Table 4: Chemical Composition of SS431

Grade	C	Mn	Si	P	S	Cr	Ni
431	min	-	-	-	-	15	1.25
	max	0.20	1	1	0.04	0.03	2.50

3.5.3 Meshing

After the geometry is generated, the 3D model of the probe meshes with an element size of 1mm. And the workpiece meshed with the element size of 2mm. Fine mesh is given to enhance the accuracy.

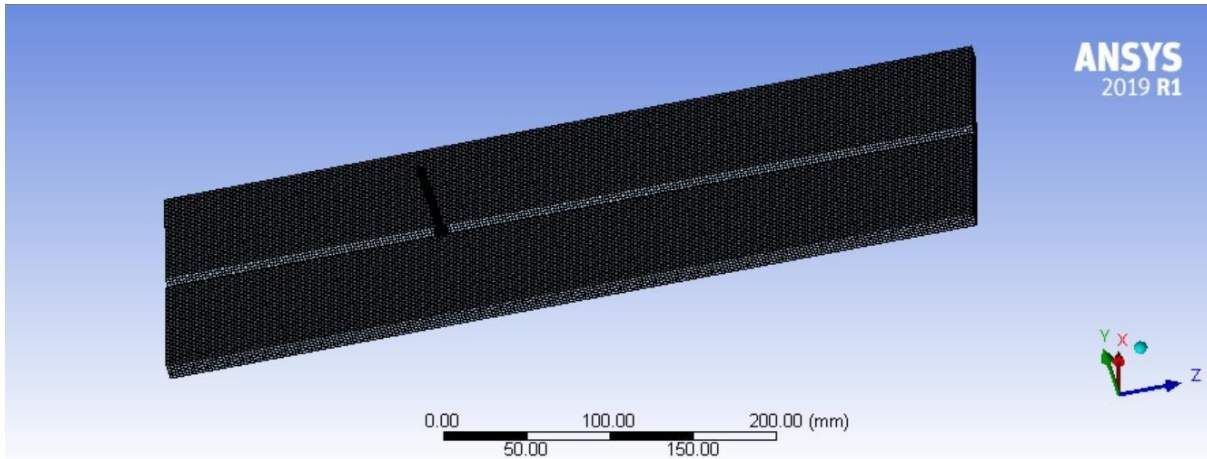

Figure 22. The meshing of the probe and workpiece

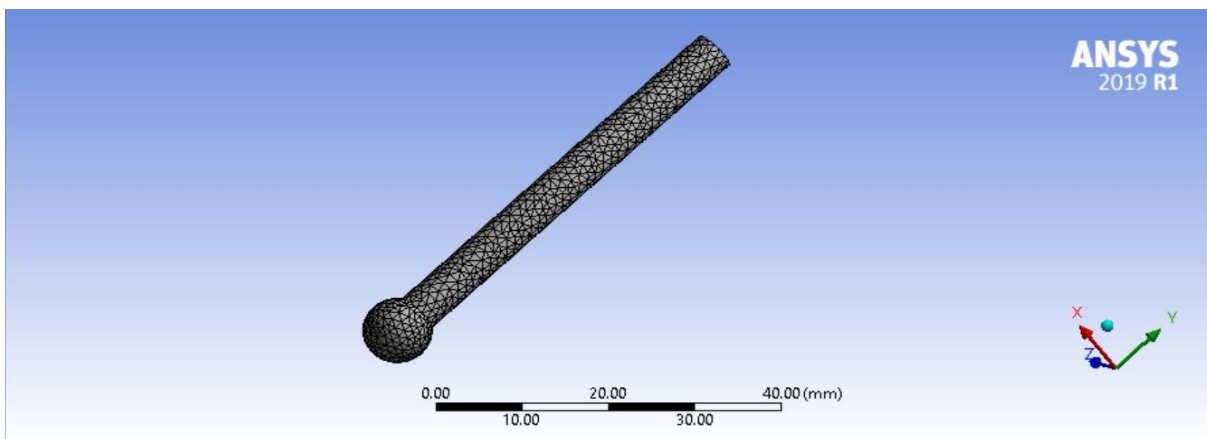

Figure 23. The meshing of the Probe tip

3.5.4 Steady state thermal analysis

During the welding conditions, thermal stresses are induced in the probe due to the contact between the probe and the workpiece and also due to the heat of the welding torch. These thermal stresses may cause the probe to deform, which might affect the sensing mechanism of the system. Data obtained from a deformed probe will not be accurate, hence it affects the efficiency of the whole system. Steady-state thermal analysis shows the distribution of stress on the component and the design can be modified later.

Temperature Constraints:

After discussing the practical operating parameters with the industry from the domain of welding automation (Figure 24), the initial temperature of the workpiece is 200 C and the conventional temperature on the probe is 22 C. The figure below shows the initial temperature constraints given to the probe and workpiece.

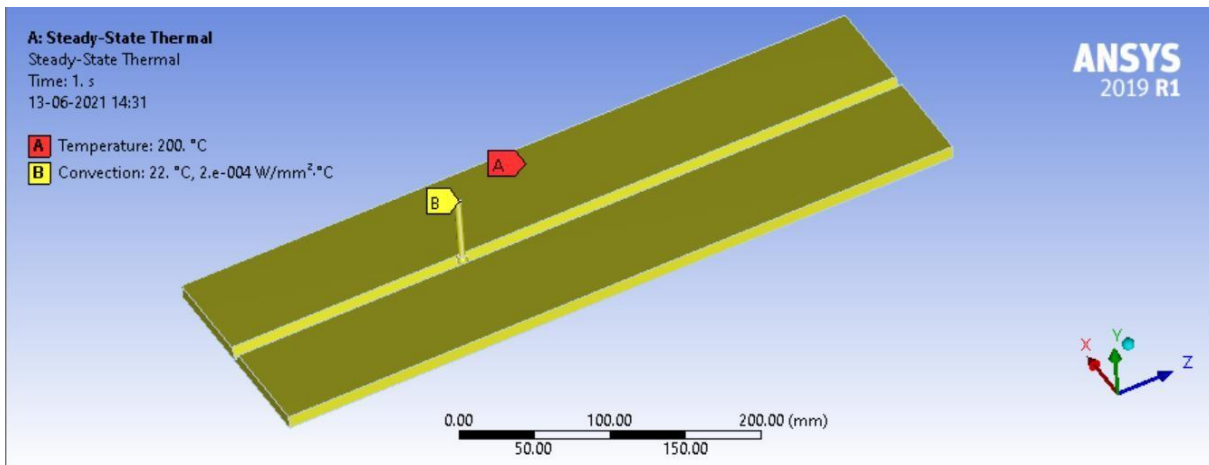

Figure 24. Temperature Constraints

Results:

The temperature distribution is shown in [Figure 25](#). The maximum temperature is at the two points of the probe which are in direct contact with the side faces of the V joint. The two faces of the V joint are under the temperature and when they come in contact with the points of the probe tip, Heattransfer occurs therefore those points on the probe are shown as a high-Temperature zone. The other points of the probe are away from the joints so they experience less temperature as compared to the tip of the probe. S, these areas are shown in different shades of blue. The temperature goes on decreasing as we move away from the probe tip and is minimum at the edge of the ship.

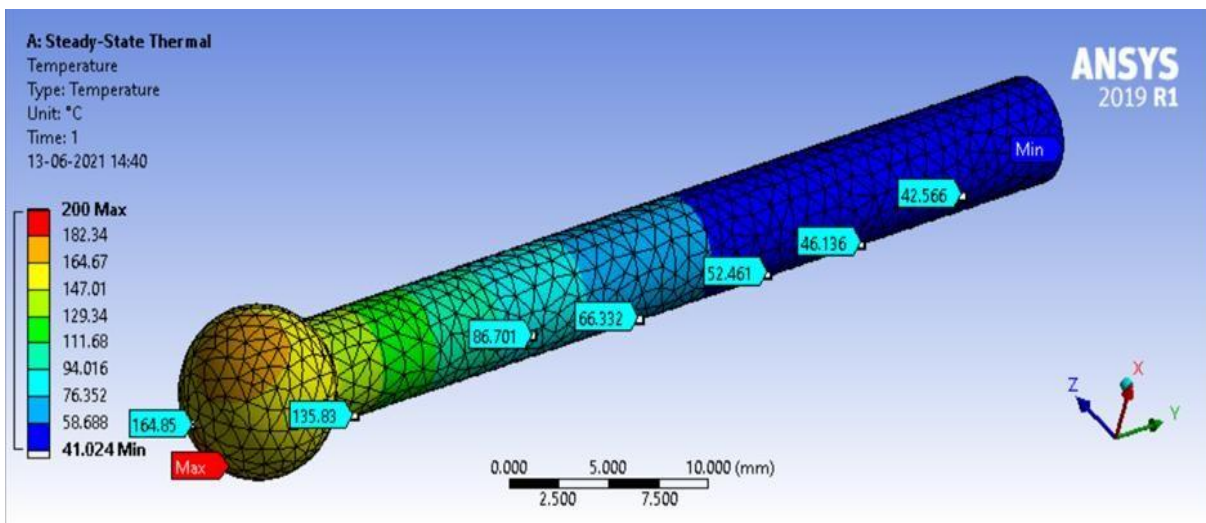

Figure 25. Temperature distribution along the probe

3.5.5 Static Structural analysis of the Spherical probe tip:

The Sensing Probe goes through Displacement, Stresses, Strains and Forces caused by loads so it is necessary to perform Static structural analysis. The Probe is under small pressure which keeps it in contact with the V joint, so to find the stresses induced in the probe after the pressure is applied along with the Thermal Stresses, Static Structural Analysis is performed. The Static Structural analysis using the Fatigue tool also helps in predicting the Factor of Safety and Fatigue Life of the probe.

Loads and Constraints:

Along with the thermal stresses, the stresses due to pressure also has to be considered. So, the pressure of 1.0053×10^{-4} MPa is applied at the two upper faces of the probe. And the results are manipulated by Ansys solver. The Workpiece is fixed as the workpiece is clamped during the welding operation. Refer to [Figure 26](#).

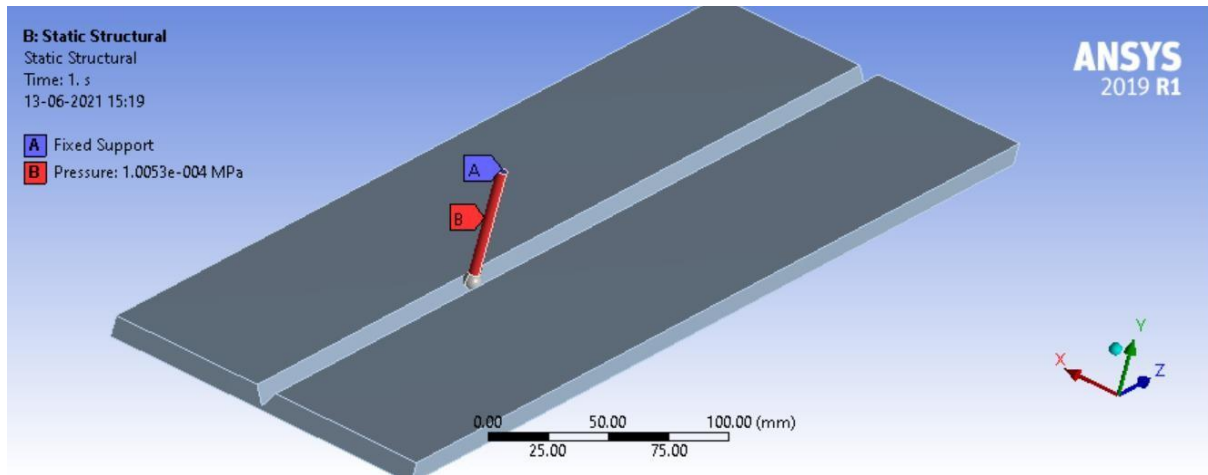

Figure 26. Loads and Constraints

Results:

Above [Figure 27](#) shows the equivalent stress of the probe. The stress distribution is more at the two points of the probe tip as these points are coming in contact with the V joint. Some amount of stress is also observed at the top holding face of the probe because of the pressure acting on the faces of the probe. The Maximum stress is 126.18 MPa and the minimum is 0.0125 MPa.

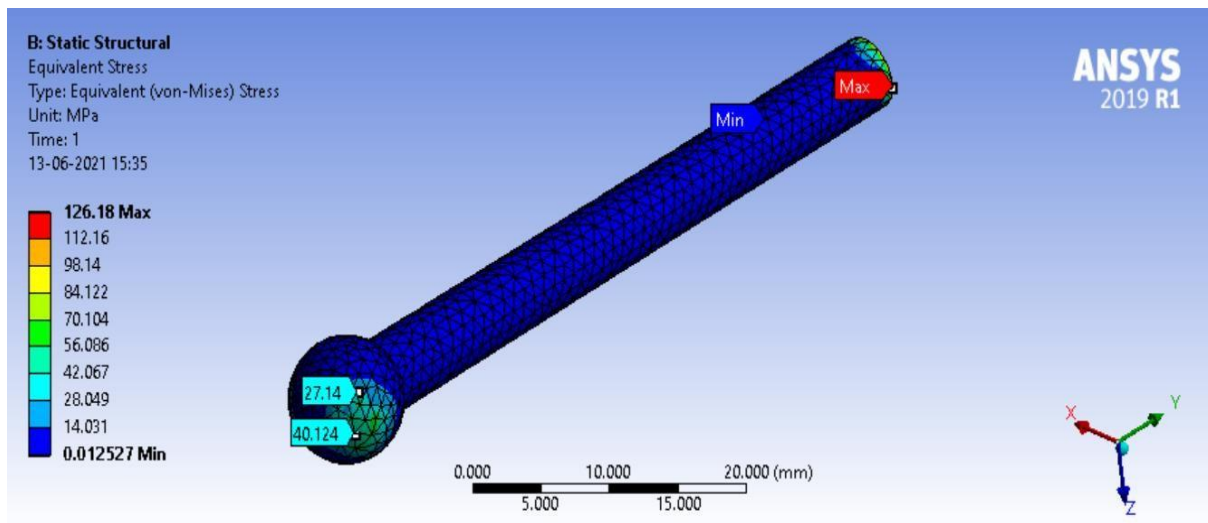

Figure 27. Equivalent stress

[Figure 28](#) shows the Total deformation of the probe. Deformation is negligible compared to the dimension of the probe. Maximum deformation occurs at the circular probe tip i.e., 0.8723 mm and Minimum at the edge of the probe i.e., 0.09692 mm.

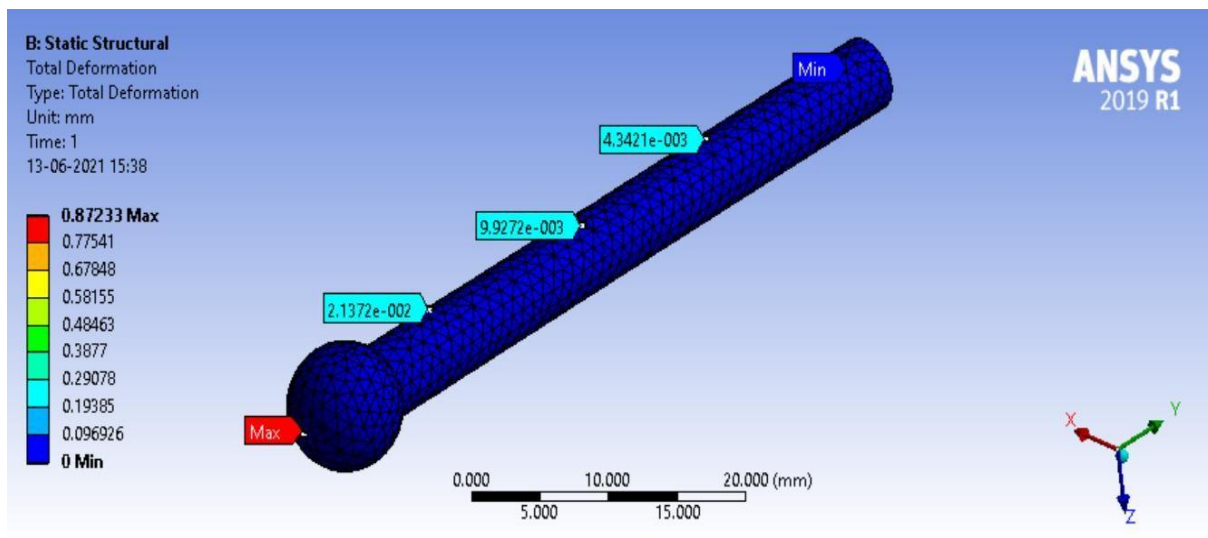

Figure 28. Distribution of Total Deformation

3.5.6 Factor of Safety

A factor of safety is a significant parameter as it expresses how strong the system is and how strong the system needs to be. The factor of safety is the ratio of yield stress to working stress. If the factor of safety is greater than 1, then the design is considered to be safe.

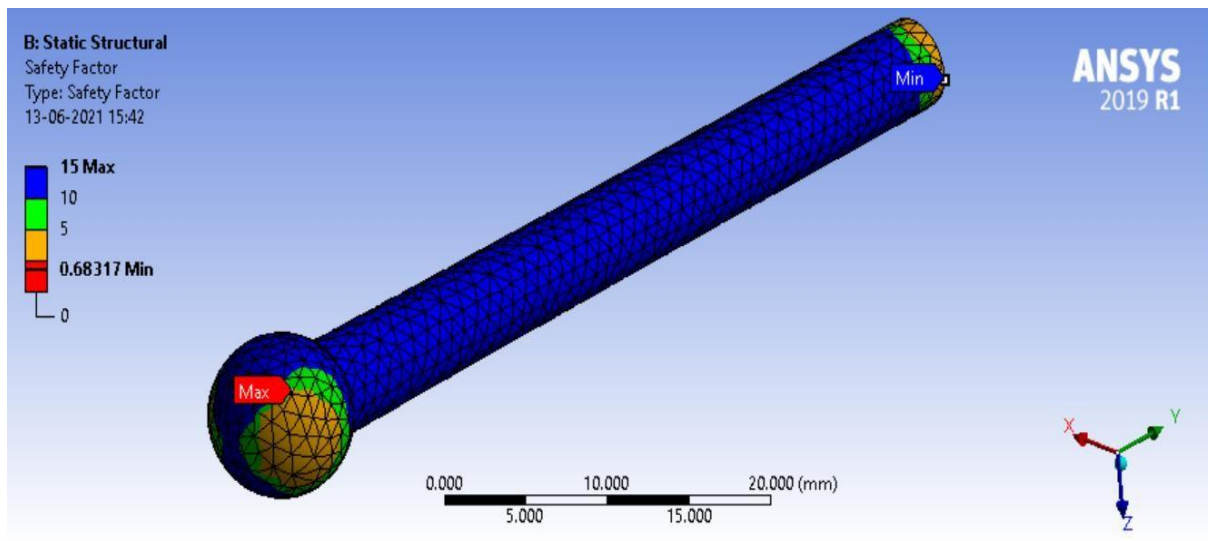

Figure 29. Safety Factor

Above [Figure 29](#) shows the Safety Factor of the probe. The Safety factor is less at the interface of the probe tip and the holding edge of the probe, but the overall design is safe. A factor of safety obtained is nearly equal to 1, so the design is considered as safe.

3.5.7 Life of the Spherical probe

By doing fatigue analysis, the life of the spherical probe was found to be 30 years, if the probe worked for 2 hours in 1 cycle. The study results are shown below in [Figure 30](#).

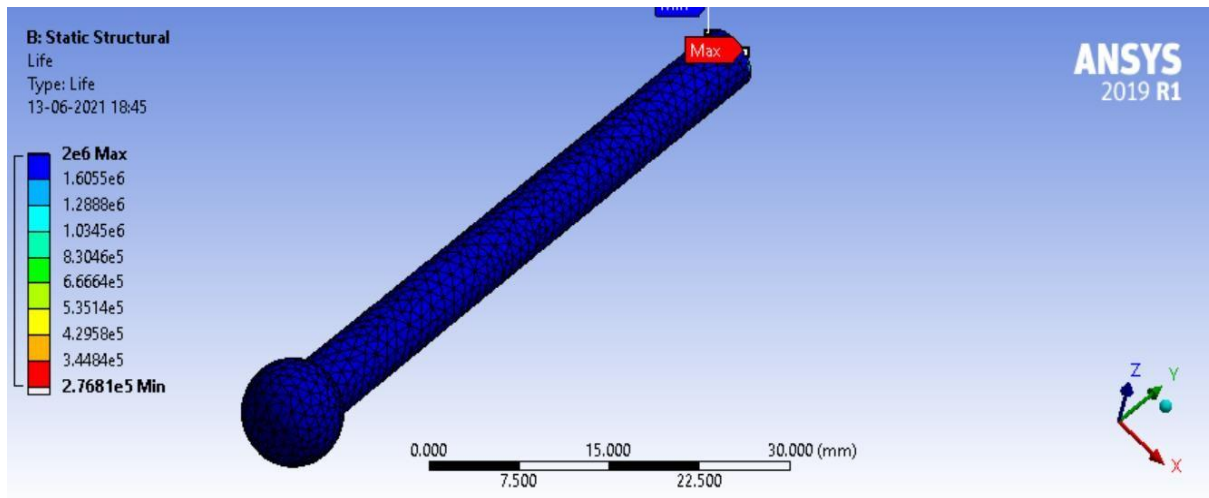

Figure 30. Life of the spherical probe Tip

The overall result of the study done on the spherical:

From the data obtained from the overall analysis, it is observed that the distribution of thermal stress is more at the tip of the probe as it touches the joint of the workpiece. The contact section of the probe goes through a small amount of thermal deformation. Stresses due to the load acting on the probe are also concentrated at the contacts of the probe and workpiece. A factor of safety was found to be more than 1, even in the sections of high-stress concentrations. Hence, the overall design is safe. The results obtained from fatigue analysis, the life of the probe was observed to be 30 years which is double of the roller probe designed

3 CONCLUSIONS

Optical seam tracking is a popular method used in industry for tracking the weld joint, however, it comes with the following disadvantages. Firstly, The depth of the V-Joint of the shiny metal like aluminium cannot be determined. Also, Outside light interference can alter the performance as well as the results obtained. Secondly, The cost of the laser system is very high, making it an unfavourable option for small-scale industries. Another seam-tracking technique using a tactile sensor has been designed to eliminate these problems. The sensing operation is done by the probe, which reduces the overall cost of the system. In addition to this, no filter system is required to reduce the noise in the output data.

The tactile seam tracking system is designed by analyzing the component in the welding condition by using simulation software. Initially, A sensing probe with a roller was used in this system and it was later replaced by a spherical probe. The stresses induced at the interface of the probe and the weld joint were more in the roller probe tip as compared to the spherical tip. It can be concluded that the spherical tip will not get deformed and can be used for a longer time. By doing fatigue analysis, the life of the spherical probe was found to be 30 years and that of the rolling probe was found to be 15 years, which shows that the life of the spherical probe is more than the rolling probe, if both the probe work for 2 hours in 1 cycle. As the deformation due to load and temperature are less in the spherical probe, the data sent to the controller will be accurate. The overall results prove that using a spherical probe will be an efficient, long-lasting and cost-effective option for the industry.

REFERENCES

[1] Wolffenbittel, R. F., & Regtien, P. P. L. (1986, October). Integrated capacitive tactile imaging sensor. In Proc. 16th Int. Symp. Industrial Robots, Brussels (pp. 633-641). [https://doi.org/10.1016/0250-6874\(89\)80068-X](https://doi.org/10.1016/0250-6874(89)80068-X)

[2] Pires, J. Norberto & Loureiro, A. & Godinho, T. & Ferreira, P. & Fernando, B. & Morgado, Joel. (2003). Welding robots. Robotics & Automation Magazine, IEEE. 10. 45 - 55. [10.1109/MRA.2003.1213616. https://www.researchgate.net/publication/3344650_Welding_robots](https://www.researchgate.net/publication/3344650_Welding_robots)

- [3] Chen, S.B. (2011). Research Evolution on Intelligentized Technologies for Robotic Welding at SJTU. In: Tarn, TJ., Chen, SB., Fang, G. (eds) Robotic Welding, Intelligence and Automation. Lecture Notes in Electrical Engineering, vol 88. Springer, Berlin, Heidelberg. https://doi.org/10.1007/978-3-642-19959-2_1
- [4] De Xu, Min Tan, Xiaoguang Zhao and Zhiguo Tu. Seam Tracking and Visual Control for Robotic Arc Welding Based on Structured Light Stereovision. International Journal of Automation and Computing, vol. 1, no. 1, pp. 63-75, 2004. <https://doi.org/10.1007/s11633-004-0063-0>
- [5] (1996). A robust visual seam tracking system for robotic arc welding. Mechatronics, 6(2), 141-163. [https://doi.org/10.1016/0957-4158\(95\)00069-0](https://doi.org/10.1016/0957-4158(95)00069-0)
- [6] Gao, X., & Na, S. (2005). Detection of weld position and seam tracking based on Kalman filtering of weld pool images. Journal of Manufacturing Systems, 24(1), 1-12. [https://doi.org/10.1016/S0278-6125\(06\)00002-1](https://doi.org/10.1016/S0278-6125(06)00002-1)
- [7] Gu, W.P., Xiong, Z.Y. & Wan, W. Autonomous seam acquisition and tracking system for multi-pass welding based on vision sensor. Int J Adv Manuf Technol 69, 451–460 (2013). <https://doi.org/10.1007/s00170-013-5034-6>
- [8] Kim, C., Choi, T., Suh, J., Park, K., Lee, J., Kang, H., Lee, M., & Kim, S. (2008). Sensor Guided Laser Welding Robot System. IFAC Proceedings Volumes, 41(2), 4324-4329. <https://doi.org/10.3182/20080706-5-KR-1001.00728>
- [9] Xu, D., Fang, Z., Chen, H. et al. Compact visual control system for aligning and tracking narrow butt seams with CO₂ gas-shielded arc welding. Int J Adv Manuf Technol 62, 1157–1167 (2012). <https://doi.org/10.1007/s00170-011-3873-6>
- [10] Shen, H., Lin, T., Chen, S. *et al.* Real-Time Seam Tracking Technology of Welding Robot with Visual Sensing. *J Intell Robot Syst* 59, 283–298 (2010). <https://doi.org/10.1007/s10846-010-9403-1>
- [11] Carolina Pimenta Mota, Marcus Vinícius Ribeiro Machado, Roberto Mendes Finzi Neto & Louriel Oliveira Vilarinho (2015) Near-infrared vision system for monitoring arc welding processes, *Welding International*, 29:3, 187-196. <https://doi.org/10.1080/09507116.2014.932975>
- [12] Zou, Y., Wei, X., & Chen, J. (2020). Conditional generative adversarial network-based training image inpainting for laser vision seam tracking. *Optics and Lasers in Engineering*, 134, 106140. <https://doi.org/10.1016/j.optlaseng.2020.106140>
- [13] Y. Zou, Y. Li, L. Jiang and L. Xue, "Weld pool image processing algorithm for seam tracking of welding robot," 2011 6th IEEE Conference on Industrial Electronics and Applications, Beijing, China, 2011, pp. 161-165, doi: 10.1109/ICIEA.2011.5975571.
- [14] Neto, P., Mendes, N., Araújo, R., Norberto Pires, J. and Paulo Moreira, A. (2012), "High-level robot programming based on CAD: dealing with unpredictable environments", *Industrial Robot*, Vol. 39 No. 3, pp. 294-303. <https://doi.org/10.1108/01439911211217125>
- [15] Zhang G, Zhang Y, Tuo S, Hou Z, Yang W, Xu Z, Wu Y, Yuan H, Shin K. A Novel Seam Tracking Technique with a Four-Step Method and Experimental Investigation of Robotic Welding Oriented to Complex Welding Seam. *Sensors*. 2021; 21(9):3067. <https://doi.org/10.3390/s21093067>
- [16] Ben-Ari, M., Mondada, F. (2018). *Sensors*. In: Elements of Robotics. Springer, Cham. https://doi.org/10.1007/978-3-319-62533-1_2
- [17] Rout, A., Deepak, B. B. V. L., & Biswal, B. B. (2019). Advances in weld seam tracking techniques for robotic welding: A review. *robotics and computer-integrated manufacturing*, 56, 12-37. <https://doi.org/10.1016/j.rcim.2018.08.003>

[18] Zou, Y., & Chen, T. (2018). Laser vision seam tracking system based on image processing and continuous convolution operator tracker. Optics and Lasers in Engineering. <https://isiarticles.com/bundles/Article/pre/pdf/152342.pdf>

[19] www.kunlitech.com

[20] <https://metrology.news/ur-certified-optical-laser-seam-tracking-welding-sensors/>