

# Power Factor Detection and Data Analytics

S Vaishnav Ghautham<sup>1</sup>, Sai Namrata Kottur<sup>2</sup>, Ron CM<sup>3</sup>, Michael Aishan Rao J<sup>4</sup>, Suma S<sup>5</sup>

<sup>1</sup>Student, Dept. of Electrical & Electronics Engineering, PES University, Bangalore

<sup>2</sup>Student, Dept. of Electrical & Electronics Engineering, PES University, Bangalore

<sup>3</sup>Student, Dept. of Electrical & Electronics Engineering, PES University, Bangalore

<sup>4</sup>Student, Dept. of Electrical & Electronics Engineering, PES University, Bangalore

<sup>5</sup>Assistant Professor, Dept. of Electrical & Electronics Engineering, PES University, Bangalore

\*\*\*

**Abstract** - With the growing power demand and increasing usage of energy, the traditional electricity transmission and distribution network can be improved into an interactive service or a smart grid. Smart meters are one of the main proposed solutions for the smart grid. Hence, the implementation of this can contribute to the detection of power factor value as well as other power parameters. This information can be useful if available to users directly, as it allows for comparison and analysis of the load's efficiency. The aim of the project is to provide a medium for this data transfer from server to the client in a secure and efficient manner. Thus involving data security and analytics. With the use of a personalized android application, the user can access the data easily.

**Key Words:** Power Factor, Efficiency, Smart Grid, Android Application.

## 1. INTRODUCTION

With the growing power demand, the traditional electricity transmission and distribution network can be improved into an interactive service or a smart grid. Smart meters are one of the main proposed solutions for the smart grid.

The implementation of this network can contribute to the detection of power factor value as well as other power-parameters. This information can be useful if available to users directly, as it allows for comparison and analysis of the load's efficiency. The aim of the project is to establish a secure and an effective medium to transfer data from the server to the client. The involvement of data encryption will further enhance the system. With the use of a personalized android application, the user can access the data effortlessly.

## 2. POWER FACTOR

The primary motive of any mechanized industry is the efficient utilization of energy. The power factor of any electrical system plays a significant role in determining

how efficient it is to do the useful work. The main definition of power factor (PF) of an AC electrical power system is "the ratio of the real power flowing to the load, to the apparent power in the circuit". Real power (kW) is considered as the capacity of the circuit for performing work in a particular time whereas apparent power (kVA) is the product of the current and voltage of the circuit.

Reactive power is the power that isn't used to do work on load.

The formula of power factor can be expressed as follows -

$$\text{Power Factor} = \frac{\text{Real Power (kW)}}{\text{Total Power (kVA)}} \quad (1)$$

The ideal power factor is known to be unity, or one. It is the most desirable power factor value and anything less than unity means that extra power is required to achieve the same output.

## 3. ZERO CROSSING METHOD

The main method used in the project to determine the power factor of an industrial load is the zero-crossing method. Zero crossing detection (ZCD) is the most common method for measuring the frequency or the period of a periodic signal. When the frequency of a signal, usually the number of cycles of a reference signal is measured over one or more time periods of the signal being measured.

Measuring multiple periods helps to reduce errors caused by phase noise by making the perturbations in zero crossings small relative to the total period of the measurement.

The net result is an accurate measurement at the expense of slow measurement rates. ZCD is one of the ways that can be used to find the power factor of a given load. The voltage and current wave-forms are recorded. From multiple cycles : each of 20ms (50Hz), the zero crossing point is determined. Since a 10 bit ADC is used (it has

1024 values), the zero crossing point found from the sensor is always around 512.

#### 4. SIGNIFICANCE OF DATA SECURITY

The main intention of data security is to ensure that only the authorized users can read, write and change the data that is being transferred or received. In the project one of our main goals is to safe-guard the data being sent between the server and client. To avoid data breaching, we have incorporated the concept of Firebase Real-Time Database security rules and an encryption algorithm. Its security rules determine who has read and write access to your database, how your data is structured, and what indexes exist. Data values like the voltage, current and power readings will be shared via the firebase database.

#### 5. METHODOLOGY

The complete integration of the hardware and software architecture is done for the detection of power factor in an industrial environment.

The power factor values are found using the zero crossing method. The raw sensor values recorded from the current and voltage sensors are plotted. The graph obtained has two sinusoidal waveforms, one being the voltage and one being current. The zero crossing point of both the waveforms are found and then, the time difference is found between them. The smart meter will send the calculated values (Power, Power factor, Penalty factor, Power consumption) in an encrypted format to the online database where the data will be stored. This encrypted data will then be available for access to the user on another database, where individual values will be decrypted and shown accordingly. the user with the help of an android application can view the collected data from the loads considered in an organized manner.

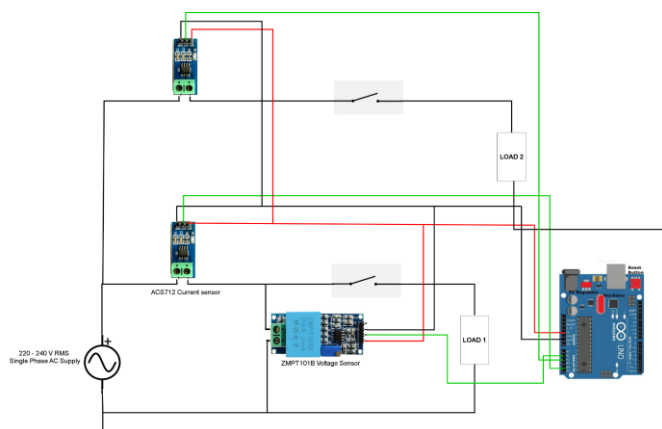

Fig 1: Circuit Diagram of the Smart meter

#### 6. HARDWARE ARCHITECTURE

This product's hardware revolves around the design and operation of a smart meter. The smart meter that we have built can take two loads into consideration (working in tandem). A voltage sensor (ZMPT101B) and two current sensors (ACS712) are used to record the V and I values respectively. The voltage sensor is connected in parallel to both the loads, whereas two current sensors are used individually for each load (connected in series).

The raw sensor voltage will be converted to current this way: raw voltage \* resolution. This will be subtracted by 2.45 (offset value). We divide the final voltage by 0.185 which is the sensitivity for acs712, as given in the datasheet.

We take 235 current values which when combined contribute to a current waveform. We then find the peak current value out of the 235 recorded data sets. So the maximum current value is  $I_m$ , which when divided by  $\sqrt{2}$  gives us the rms value of current.

The rms current value can be further used to determine the power factor values.

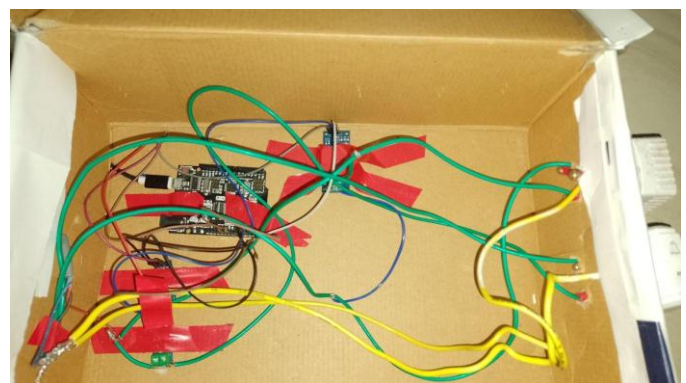

Fig 2 : Hardware Implementation of the Circuit

In addition to current parameters, raw voltage sensor values are recorded. Since a 10 bit ADC is used (ATMEGA328P), there are 1024 analog values. It is understood that the zero crossing point of the sensor will be around 512, which when compared with the operating voltage of the sensor (5V), is 2.5V. So by default, 512 is subtracted from the analog value read from the sensors. Each recorded value is squared, 1000 such values are considered where each value is read every 1 or 2 ms. The mean value of the 1000 values is found and the square root of the same is calculated. Which when multiplied with 1.5 (amplification factor) gives out the Root Mean Square Voltage.



Fig 3: Final Setup of the Prototype

### 7. SOFTWARE DEVELOPMENT

Android Studio is a reliable platform to create android projects/apps that can be accessed on devices like smartphones, tablets, etc. Android Studio along with its Gradle-based build system extends a consolidated environment where we can develop for various android devices and hence, provides extensive testing tools and frameworks.

In the app developed, we have established a connection between the Android Application and the firebase database. The application will retrieve data values from the firebase in a secure encrypted format, and as a result it will display the analyzed data in an interactive-unique style for the end user to view.

The smart meter will send the calculated values (Power, Power factor, Penalty factor, Power consumption) in an encrypted format to the online database where the data will be stored. This encrypted data will then be available for access to the user on another database, where individual values will be decrypted and shown accordingly. the user with the help of an android application can view the collected data from the loads considered in an organized manner.

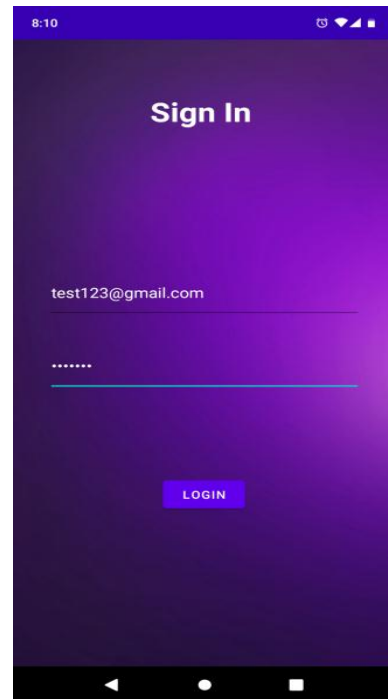

Fig 4: Android Application: User authentication

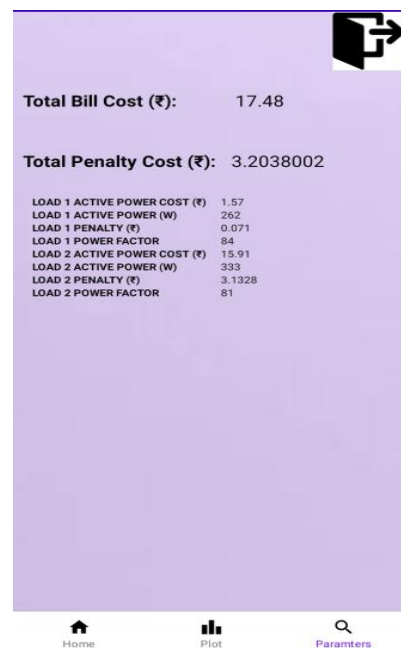

Fig 5: Android Application: Consumption Details

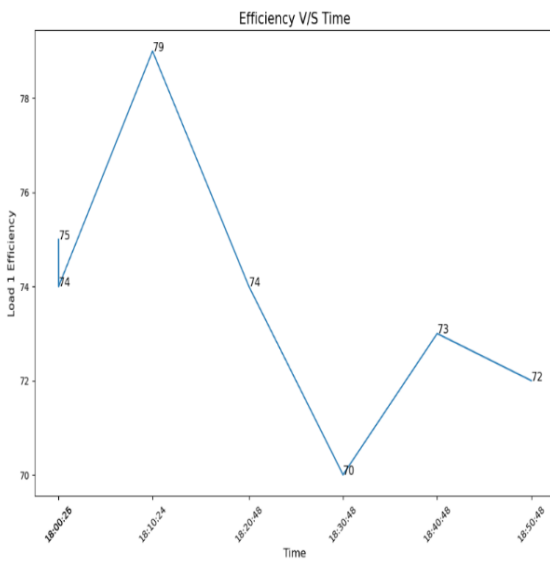

Fig 6: Android Application: Analyzed Output

### 8. CALCULATIONS

The power factor calculations can be done according to the approach implemented below:

Time Difference = 20 ms => Phase Difference = 360 degrees

Time Difference = 2 ms => Phase Difference

$$= \frac{2 * 360^0}{20} = 36^0$$

Therefore, power factor =  $\cos(36^0) = 0.8$

If the power factor is found to be less than 0.85 , a surcharge of 30 paise per unit consumed will be taxed for every reduction of Pf by 0.01, below 0.85. For example, if the averaged power factor was 0.75 for 1 unit, the *penalty factor would be*:

$$\frac{(0.85 - 0.75)}{0.01} * 30 \text{ paise} = 150 \text{ paise} = \text{Rs. } 1.5$$

The energy charges are considered from Bangalore Electric Supply board’s Documentation for 2022 - 2023 period. Since the proposed product finds power parameters for loads individually, a mean value of the above tariff rates is considered for simplicity. So, for one unit, *the cost would be*:

$$\frac{(415 * 50) + (540 * 50) + (715 * 100)}{200} = 601.25 \text{ paise} \sim = \text{Rs. } 6$$

### 9. CONCLUSION

This project deals with the design and implementation of a model which enables users to directly access the power figures and efficiency of the load used. The model also permits the comparative analysis between two different apparatus running in tandem. With the help of an android application, we have given the user a medium to access all the necessary information and the added feature of cost and penalty factor based on power consumption. The transfer and storage of such important information, made it susceptible to malware and cyber-attacks, and thus we have also implemented an encryption and decryption process thus making the data transfer safe and secure. The main reason as to why our model is so efficient is because the entire process happens on a real time basis and is automatically updated after every time interval.

### 10. FUTURE SCOPE

With the help of the proof of concept explained, the project can be extended to industry standards and provide an online platform to perform effective data analytics on power parameters which will prove to be very useful in different applications.

### 11. REFERENCES

- [1] Herrmann, Christoph & Posselt, Gerrit & Zein, André. (2010). Industrial Smart Metering – Application of Information Technology Systems to Improve Energy Efficiency in Manufacturing.
- [2] A. R. Al-Ali, I. A. Zualkernan, M. Rashid, R. Gupta and M. Alikarar, "A smart home energy management system using IoT and big data analytics approach," in IEEE Transactions on Consumer Electronics, vol. 63, no. 4, pp. 426-434, November 2017, doi: 10.1109/TCE.2017.015014.
- [3] Mishra, Nikhil & Kumar, Vinay & Bhardwaj, Garima. (2019). Role of Cloud Computing in Smart Grid. 252-255. 10.1109/ICACTM.2019.8776750.
- [4] Xun Li, Qingwu Gong, Member IEEE, Xiao Zheng, "The application of IOT in power systems", in IEEE 2011, 978-1-4577-1002-5/11
- [5] Deepak K. D. and Pawan D.,—Performance Comparison of Symmetric Data Encryption Techniques|| ISSN: 2278 – 1323 International Journal of Advanced Research in Computer Engineering & Technology Volume 1, Issue 4 June 2012.