

Effect of Pile Length on the Settlement and Straining Actions for the pile Raft foundation

Abo Bakr Alsedik, M. Abd- Elmageed, M .F. and Radwan, T. N.

Al Azhar University, Faculty of Engineering, Cairo, Egypt

ABSTRACT

The present study is mainly based on the determination of the effect of pile length on settlement and straining actions in the raft rested on piles and the effect of the contact of the raft to the soil under the effect of static load and dynamic load. The pile diameter is fixed ($D = 0.5$ m), and spacing between piles are fixed ($Sp = 4.5D$) with various pile length ($Lp = 28D, 32D, 36D,$ and $40D$). The thickness of the raft is 1.00 m and the dimensions of the raft are $10*10$ m. The borehole that was chosen to be used in the analysis of soil consists of six layers which are Silty sand and traces of clay, Silty sand, medium stiff clay, and dense sand, and is simulated by a semi-infinite element. Finite element package of a PLAXIS 3D version 2013. (a finite element code for soil and rock analysis) has been used to determine the bending moment, the shear force on the raft, and the settlement. In the case of piled raft resting on the soil, it was found that the bending moment in the raft decreased by 29%, the shear force in the raft decreased to 0.5% and the settlement of piled raft decreased 40% by increase the pile length under the effect of static load, the bending moment in the raft decreased by 29%, the shear force in the raft decreased to 0.5% and the settlement of piled raft decreased 40% under the effect of dynamic load. It found also that the bending moment in the raft in the case of a slab connected to the piles is greater than the case of piled raft rested on the soil by 7%. In addition, the shear force in the raft as the slab connected the piles is larger than the rested piled raft by 2%. The settlement in the case of raft act as a slab connected to the piles is higher than rested piled raft by 10%.

Keywords: Pile Length, Pile Raft Foundation

1. INTRODUCTION

The straining action and the settlement in piled raft foundation are affected by many different factors such as pile length, pile diameter raft thickness, and type of soil but to a varying degree.

Akinmusuru (1980) studied the effect of pile length and raft geometry on piled raft load sharing. Experimental results on a single piled raft unit revealed that the raft share increases extensively by enlarging the raft width, whereas the pile length has an inconsiderable impact on load sharing.

Clancy and Randolph (1993) determined an approach for the analysis of piled raft foundations based on the transfer of a load of individual piles, together with elastic interaction between different piles and with the raft. They presented the effect of raft stiffness and spacing between piles and pile length and stiffness.

Bisht, R.S. and Singh, B.(2012) presented a study on the behavior of piled raft foundation with various pile lengths it was found that settlements decrease with the increase in pile length. The maximum overall settlement at the center of piled raft decreased

Elsamny, M. K. et al. (2018) presented a study on the analysis of pile-raft foundations non-rested and directly rested on the soil. A finite element was used in this study. The vertical displacement for the group of four pile caps rested on the soil. Vertical displacement for a group of four pile caps non-rested on soil It was concluded that the group efficiency of pile groups for piles cap rested on soil is more than that for piles caps non-rested on the soil. The group efficiency was found to be ranging from 1.43 to 1.60 for four piles cap rested on soil and was found to be ranging from 1.13 to 1.25 for four piles cap non-rested on the soil. The settlement of pile groups for pile cap resting on soil is less than that for pile cap non-rested on the soil.

Elsamny, M. K. et .al (2020) Studied the effect of pile length on load sharing of pile raft foundation under different loads it was found that the stresses increase by increasing the pile length but at $Lp \geq 38D$ there is no significant effect. The load increase by increasing the length of the pile Although, the load decrease after (65 to 70) % length of the pile. The loads transferred to soil by friction increase by increasing pile length. The loads transferred to soil by end bearing decrease by increasing pile length

2. Analytical Analysis by Finite Element Analysis:

The used computer program was for the proposal of a three-dimensional finite element package of a PLAXIS 3D version 2013 model to simulate the theoretical effect of pile length in pile raft foundation

2.1 Proposed model:

In the present study, a theoretical analysis has been done for a selected site (in a governmental project in Semesta city, Beni-suef, Governorate, Egypt).Fig. (1) illustrates a borehole for the previous site that was chosen to be used in the analysis. The soil consists of four layers and is simulated by a semi-finite element

. isotropic homogenous elastic material. The analysis program consists of a piled-raft

foundation consisting of 25 piles their diameters are fixed ($D = 0.5m$) and the spacing between piles is fixed ($S_p = 4.5D$) and they have various pile lengths ($L_p = 28D, 32D, 36D,$ and $40D$). Analysis carried out on two categories as follows

- rested piled raft
 - raft act as a slab connected the piles
- The details and variations of these selected

parameters are listed in tables from (1) to (3). and figures (2) and (3)

Depth (m)	legend of borehole	end of layer	S.P.t or %Rec	un confined QU KN/m ²	Description
1	[Pattern]	2			Silty sand and trace of clay
2					
3					
4		4			Silty sand
5	[Pattern]				
6					
8					
10		12	12	100	medium stiff clay
11					
12	[Pattern]				
13					
14					
15					
16					
17					
18					
19					
20					
21					
22		30	33		dense sand
23					
24					
25					
26					
27					
28					
29					
30					

Fig. (1): Borehole Log for Soilused Sesmeta, Beni-Suef Governorate, Egypt Proje

Table (1): Investigated cases of study

NO.	Number of piles	pile diameter (m)	The contact of the raft with the soil	Length Of the piles	Pile spacing	Raft Thickness (m)
1 2 3 4	25	0.5	Rested on the soil	28D 32D 36D 40D	4.5D	1
5 6 7 8	25	0.5	The raft act as a slab connected the piles	28D 32D 36D 40D	4.5D	1

Table (2): Properties For Soil Layers

Parameters	Name	Silty sand and traces of clay	Silty sand	Medium to stiff clay	dense sand	unit
Material model	-	Moher column	Moher column	Moher column	Moher column	-
Thickness	T	2	2	8	18	m
Youngs modulus	Es	7500	8000	3000	15000	kN/m ²
Unit weight	γ	17	16.6	17	18	kN/m ³
Poisson ratio	ν	0.3	0.4	0.3	0.25	-
Cohesion	c	25	12.5	30	0	kN/m ²
Friction angle	∅	25	35	0	37	°

Table (3): pile and raft properties

Parameters	Pile	Raft
Material model	Elastic	Elastic
Types of material	Concrete	Concrete
Diameter (m)	0.5	-
Raft thickness (m)	-	1
Unit weight (kN/m ³)	25	25
young's modulus (kN/m ²) Es	24*10 ⁶	24*10 ⁶
Poisson ratio (ν)	0.2	0.2

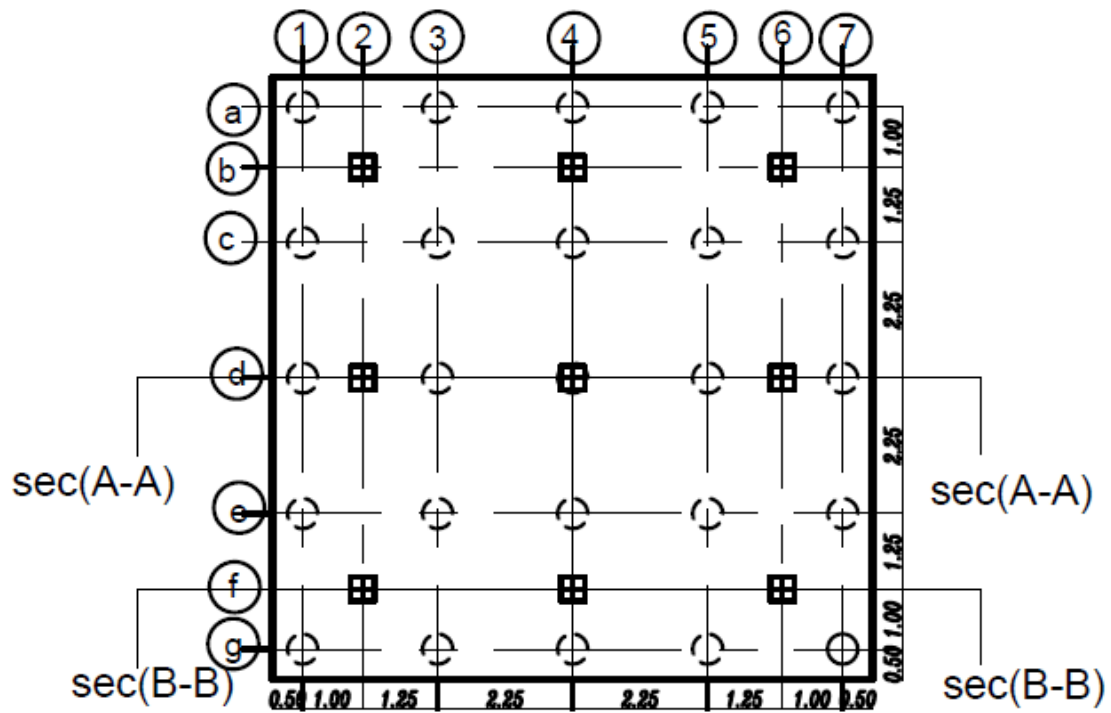

Fig (2) plane of piled raft foundation

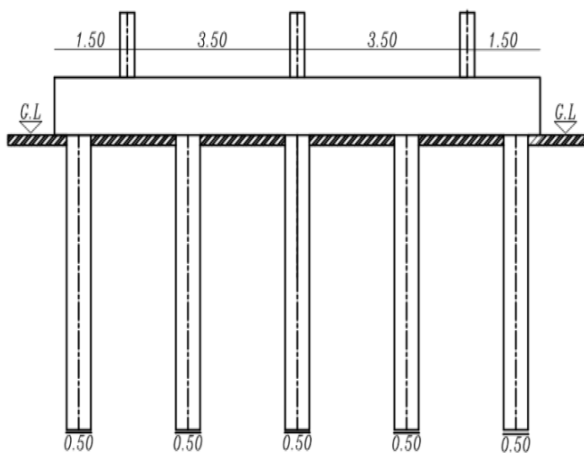

Fig (3) Cross section of piled raft foundation rested on the soil

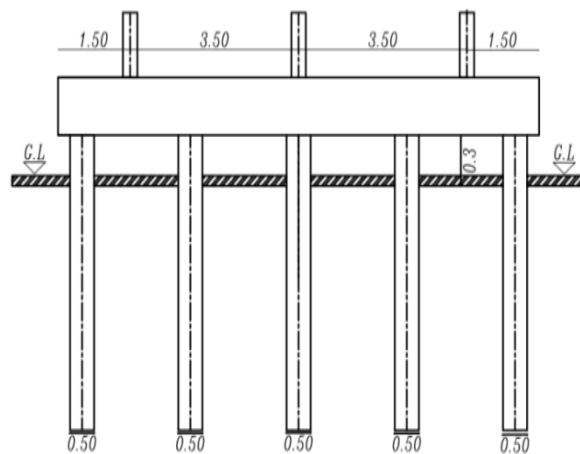

Fig (4) Cross section of piled raft foundation as raft act as slab connected the piles

Finite element model:

Figures (3) and (4) show the cross sections of the piled raft in the two cases rested on the soil and the raft act as a slab connected the piles ($L_p=32D$, $D=0.5$ m $S_p=4.5D$)

3 -Parametric study

The effect of pile length on the following:

- i. The settlement of piled raft
- ii. The bending moment on the raft
- iii. The shear force on the raft

3. 1. Finite Element Results:

The obtained results of selected examples for different cases are shown in figures (6 to 17) as follows:

Figure (6) and (7) shows the bending moment on the raft in the two cases rested on the soil and the raft act as a slab connected to the piles from the soil ($L_p = 32D$, $D = 0.5$ m, and $S_p = 4.5D$).

Figures (8) and (9) show the vertical displacement of the soil under the raft in the (x-y) plane (as shading) for the two cases ($L_p = 32D$, $D = 0.5$ m, and $S_p = 4.5D$).

Figures (10) and (11) show the vertical displacement of soil under the raft in(x-z) plane (as shading) for the two cases ($L_p = 32D$, $D = 0.5$ m, and $S_p = 4.5D$).

Figures (12) and (13) show the shear force on the raft for the two cases ($L_p = 32D$, $D = 0.5$ m, and $S_p = 4.5D$

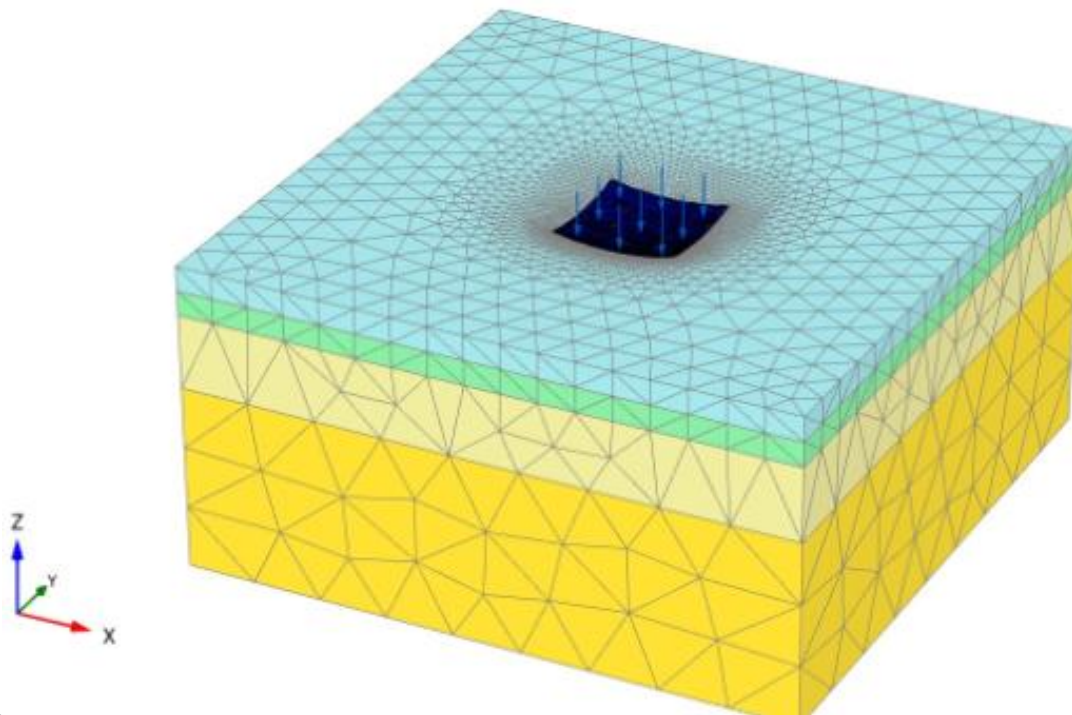
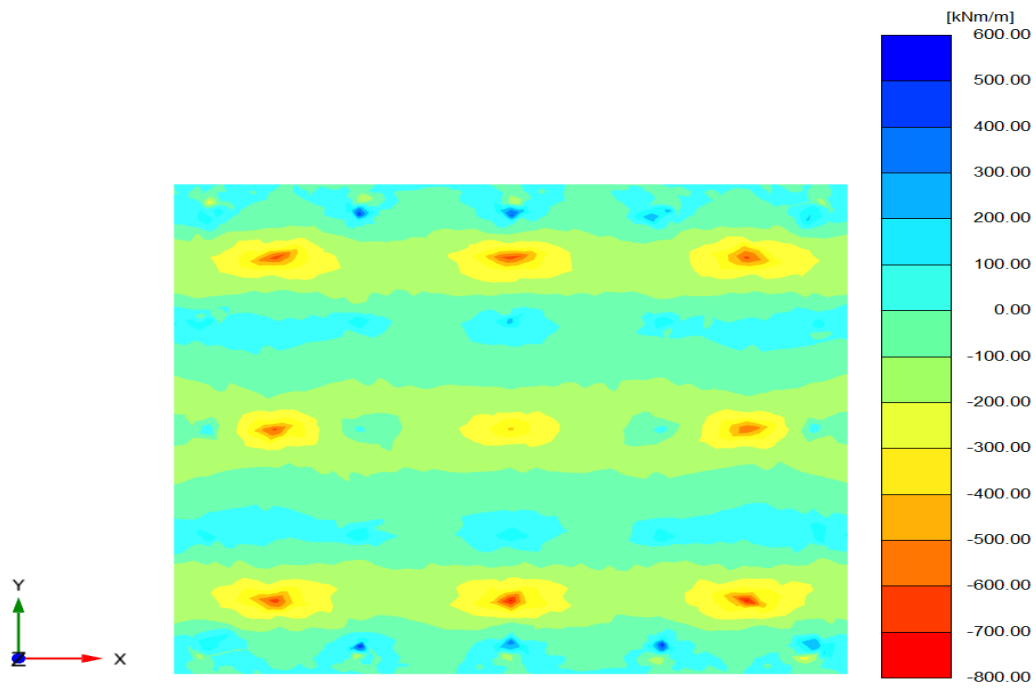
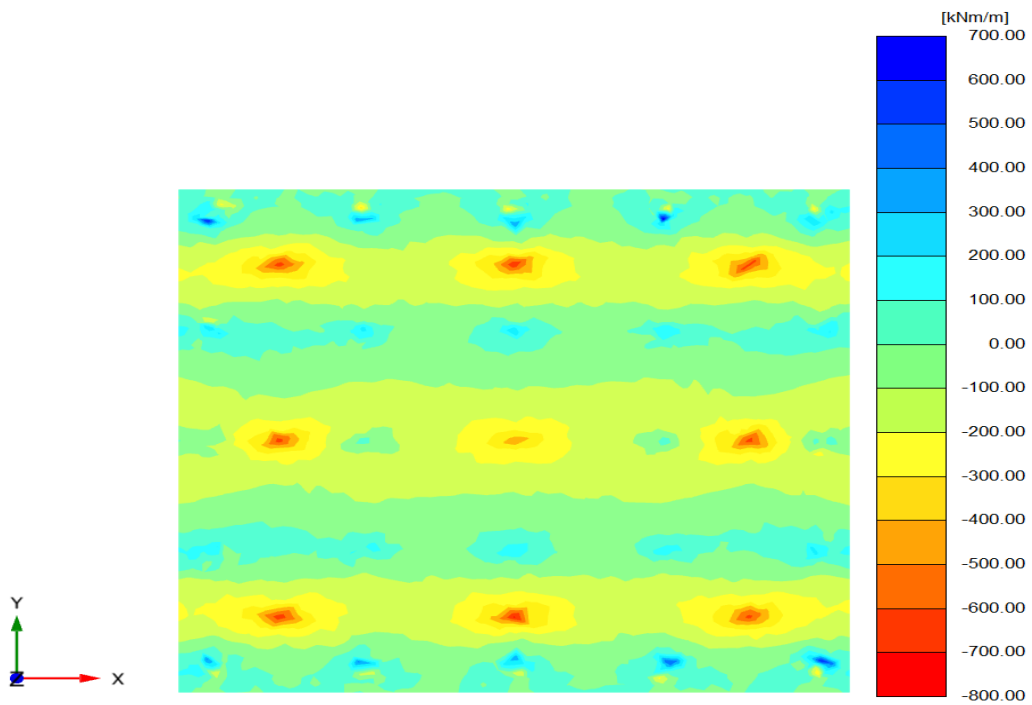

Fig (5) The deformed mesh of piled raft foundation with pile length 16m



Fig(6) The bending moment of piled raft rested on the soil with pile length 32D



Fig(7) The bending moment of the piled raft as the raft act as a slab connected to the piles with pile length 32D

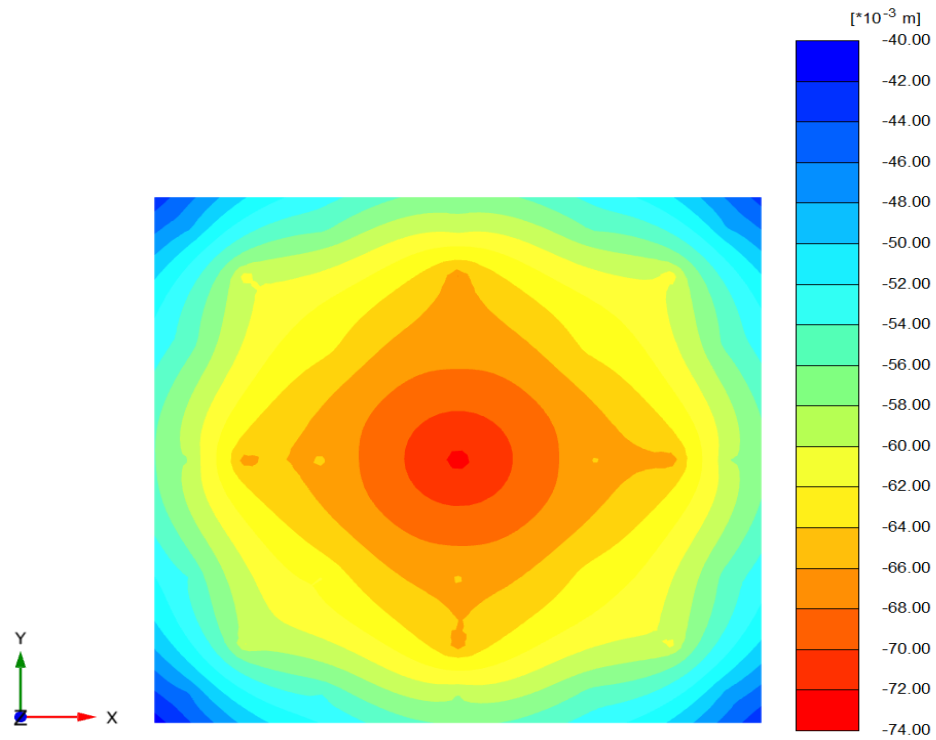
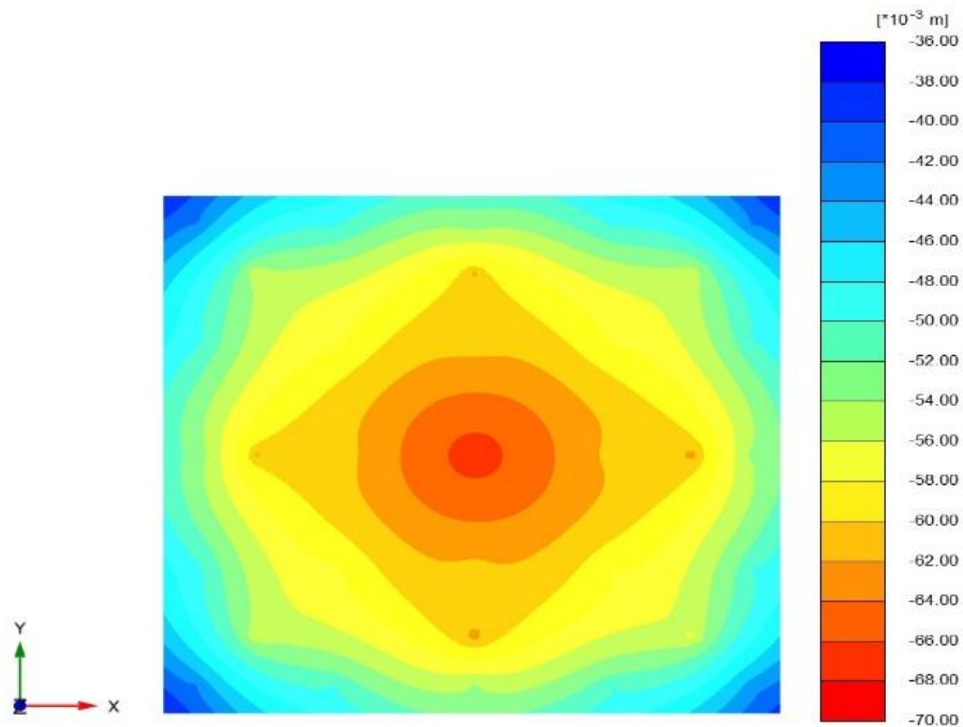

Fig (8) The vertical displacement of the soil under the raft in piled raft foundation rested on the soil with pile length 32D



Fig(9) The vertical displacement of the soil under the raft of piled raft foundation as raft act as slab connected the piles with pile length 32D

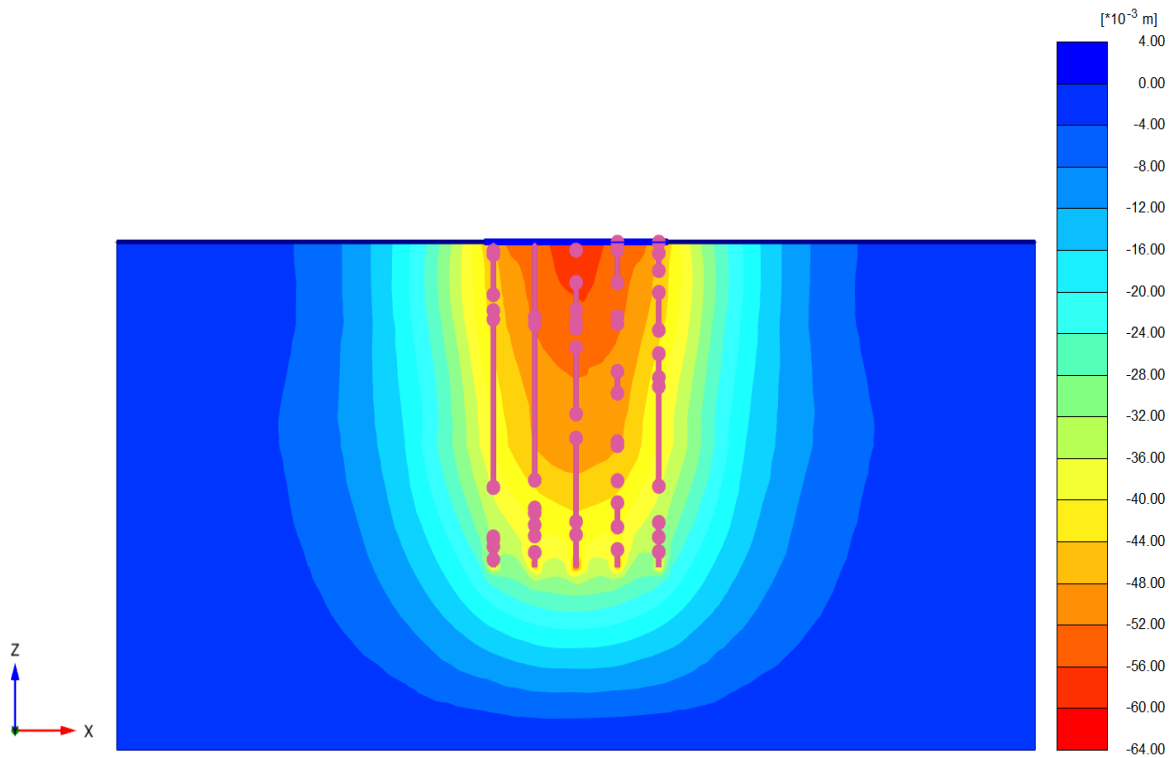

Fig (10) The vertical settlement as shading for the soil in the XZ plane of piled raft foundation rested on the soil with a pile length 32D

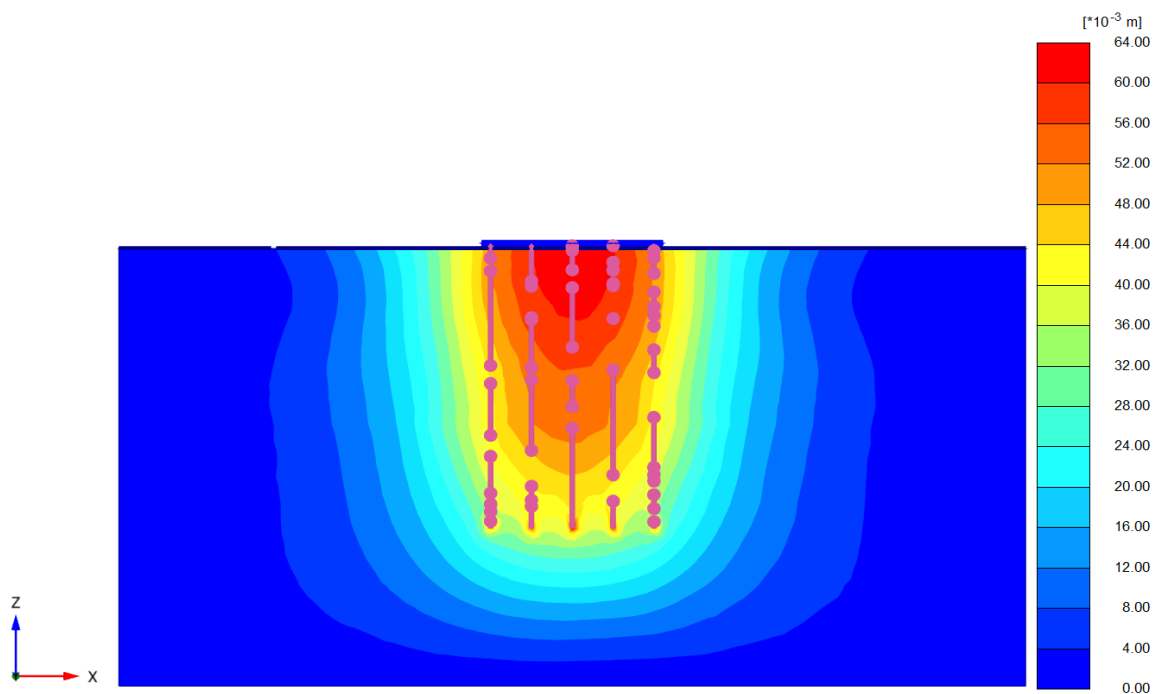

Fig (11) The vertical settlement as shading for the soil in the XZ plane of piled raft foundation as the raft act as a slab connecting the piles with pile length 32

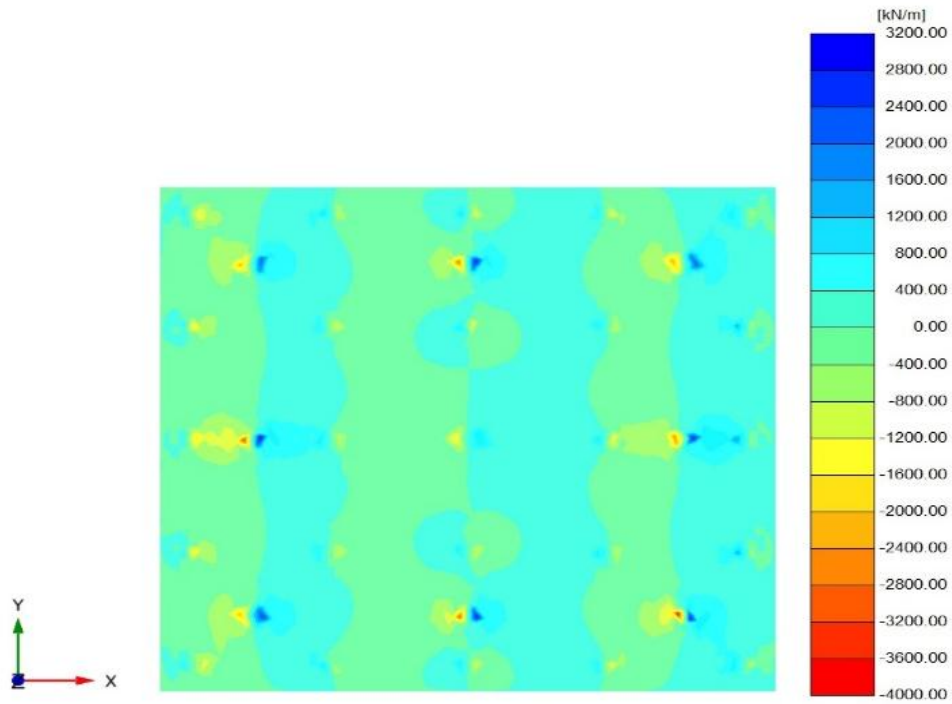

Fig (12) The shear force of the raft for piled raft foundation rested on the soil with pile length 32D

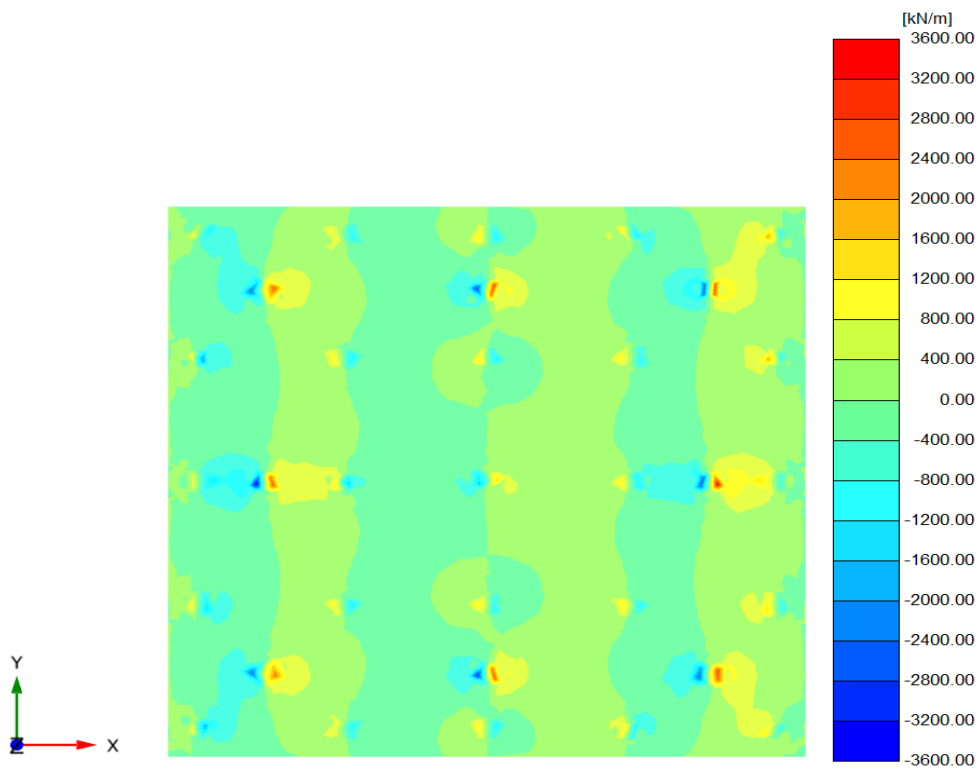

Fig (13) The shear force of the raft for piled raft foundation as the raft act as a slab connected the piles with pile length 32D

3. 2. Analysis of results:

Figures (14), (15) shows the relation between vertical settlement on the raft in the two cases with various pile length = where $L_p = (28D, 32D, 36D, \text{ and } 40D)$ for ($D = 0.5 \text{ m}$), with raft thickness 1m in sec A. It can be observed that with increasing pile length from 28D to 40D the settlement decreases 40% in the case of piled raft rested on the soil and settlement decreased 35% in the case of piled raft with raft act as slab connected the pile.

Figures (16), (17) shows the relation between vertical settlement on the raft in the two cases with various pile length = where $L_p = (28D, 32D, 36D, \text{ and } 40D)$ for ($D = 0.5 \text{ m}$), with raft thickness 1m in sec B. It can be seen that with increasing pile length from 28D to 40D the settlement decreases 38% in the case of piled raft rested on the soil and the settlement decreases 35% in the case of piled raft with raft act as slab connected the pile.

Figures (18) and (19) shows the relation between the bending moment of the raft in the two cases with various pile length where $L_p = (28D, 32D, 36D, \text{ and } 40D)$ for ($D = 0.5 \text{ m}$), with raft thickness = 1m in sec A. It can be observed that with increasing pile length from 28D to 40D the bending moment in the raft decrease 29% in the case of piled raft rested on the soil and the bending moment in the raft decreases 20% in the case of piled raft with raft act as slab connected the pile.

Figures (20) and (21) shows the relation between the bending moment of the raft in the two cases with various pile length where $L_p = (28D, 32D, 36D, \text{ and } 40D)$ for ($D = 0.5 \text{ m}$), with raft thickness = 1m in sec B. It can be observed that with increasing pile length from 28D to 40D the bending moment in the raft decreases from 1% to 2%. in the case of piled raft rested on the soil and the bending moment in the raft decreases from 1% to 1.5% in the case of piled raft with raft act as slab connected the pile.

Figures (22), (23) shows the relation between the shear force on the raft in the two cases with various pile length where $L_p = (28D, 32D, 36D, \text{ and } 40D)$ for ($D = 0.5 \text{ m}$), with raft thickness 1m in sec A from these figures, it can be shown with increasing pile length from 28D to 40 D the shear force on the raft decreased from 1% to 0.5% in the case of piled raft rested on the soil and the shear force on the raft decreases from 1% to 0.5%. in the case of piled raft with raft act as slab connected the pile.

Figures (24), (25) shows the relation between the shear force on the raft in the two cases with various pile length

where $L_p = (28D, 32D, 36D, \text{ and } 40D)$ for ($D = 0.5 \text{ m}$), with raft thickness 1m in sec B. it can be observed that with increasing pile length from 28D to 40D the shear force on the raft decreases from 1% to 0.5%. in the case of piled raft rested on the soil and the shear force on the raft decreases from 1% to 0.5%. in the case of piled raft with raft act as a slab connected the pile.

Figures (26), (27) and fig (38) show comparison in the settlement, bending moment and shear force between piled raft foundation rested on the soil and piled raft foundation with raft act as slab connected the piles where $L_p = 28D$ and raft thickness (1m). it can be concluded that the settlement in the piled raft in the case of raft act as slab connected to the piles is greater than the case of rested piled raft by 10%, the bending moment in the raft in the case of a raft act as a slab connected to the piles is greater than the case of a rested piled raft by 7% and the shear force in a raft in the case of a raft act as a slab connected the piles is greater than in the case of a rested piled raft by 2%.

Figures (29), (30) shows the relation between settlement on the raft in the two cases with various pile length = where $L_p = (28D, 32D, 36D, \text{ and } 40D)$ for ($D = 0.5 \text{ m}$), with the effect of dynamic load and static load, with raft thickness 1m in sec A. It can be observed that with increasing pile length from 28D to 40D the settlement decreases 40% in the case of piled raft rested on the soil and settlement decreased 35% in the case of piled raft with raft act as slab connected the pile.

Figures (31) and (32) shows the relation between the bending moment of the raft with the effect of dynamic load and static load, in the two cases with various pile length where $L_p = (28D, 32D, 36D, \text{ and } 40D)$ for ($D = 0.5 \text{ m}$), with raft thickness = 1m in sec A. It can be observed that with increasing pile length from 28D to 40D the bending moment in the raft decrease 29% in the case of piled raft rested on the soil and the bending moment in the raft decreases from 20% in the case of piled raft with raft act as slab connected the pile.

Figures (33), (34) shows the relation between the shear force on the raft in the two cases with various pile length where $L_p = (28D, 32D, 36D, \text{ and } 40D)$ for ($D = 0.5 \text{ m}$), with the effect of dynamic load and static load with raft thickness 1m in sec A from these figures, it can be shown with increasing pile length from 28D to 40 D the shear force on the raft decreased 0.5% in the case of piled raft rested on the soil and the shear force on the raft decreases 0.5%. in the case of piled raft with raft act as slab connected the pile.

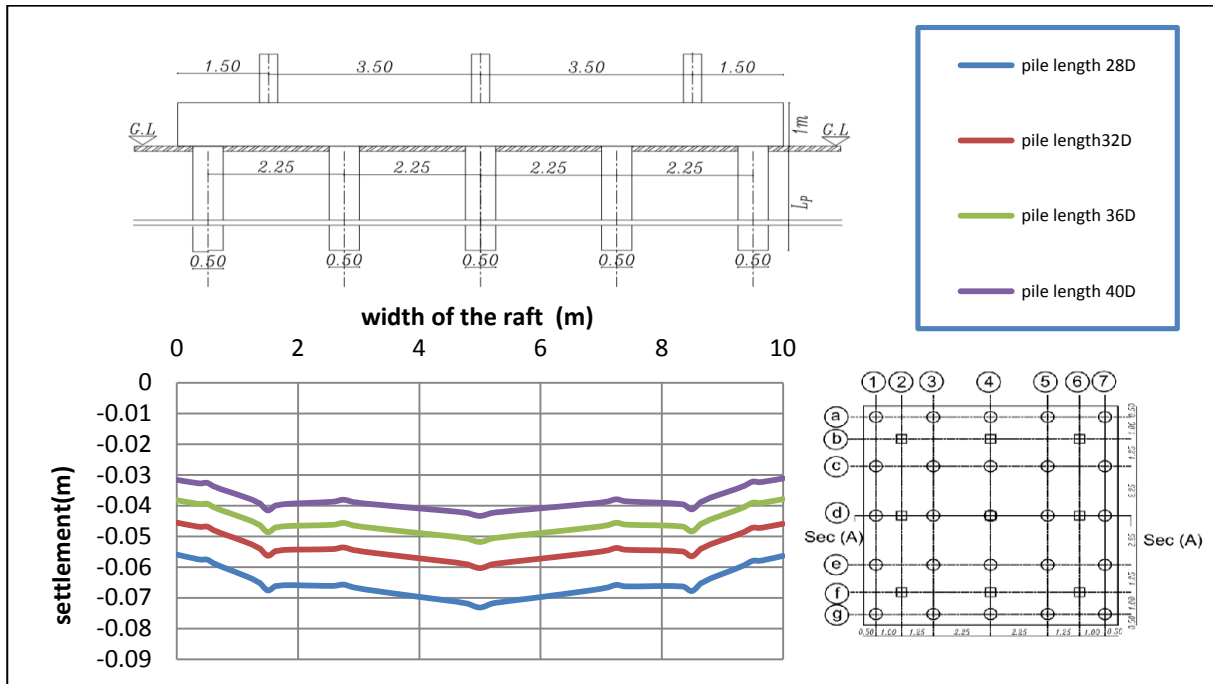

Fig (14) The relation between pile length and the settlement of piled raft foundation rested on the soil at s ecc A

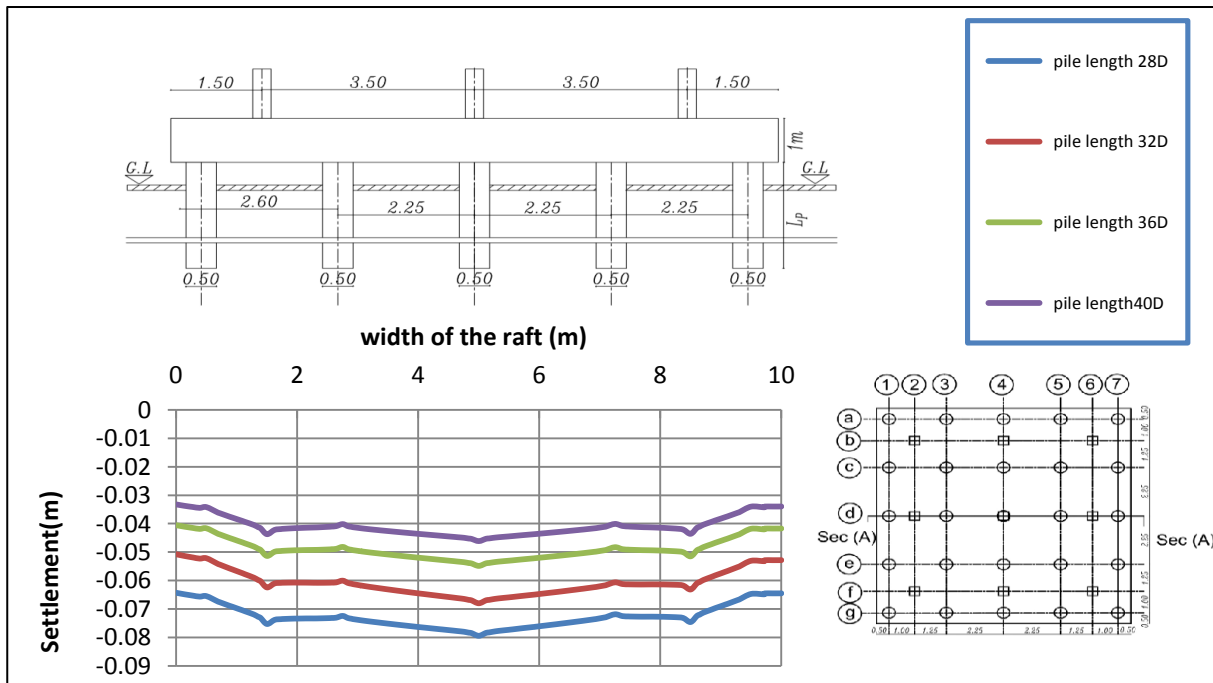

Fig (15) The relation between pile length and the settlement of piled raft foundation as the raft act as a slab at SEC A.

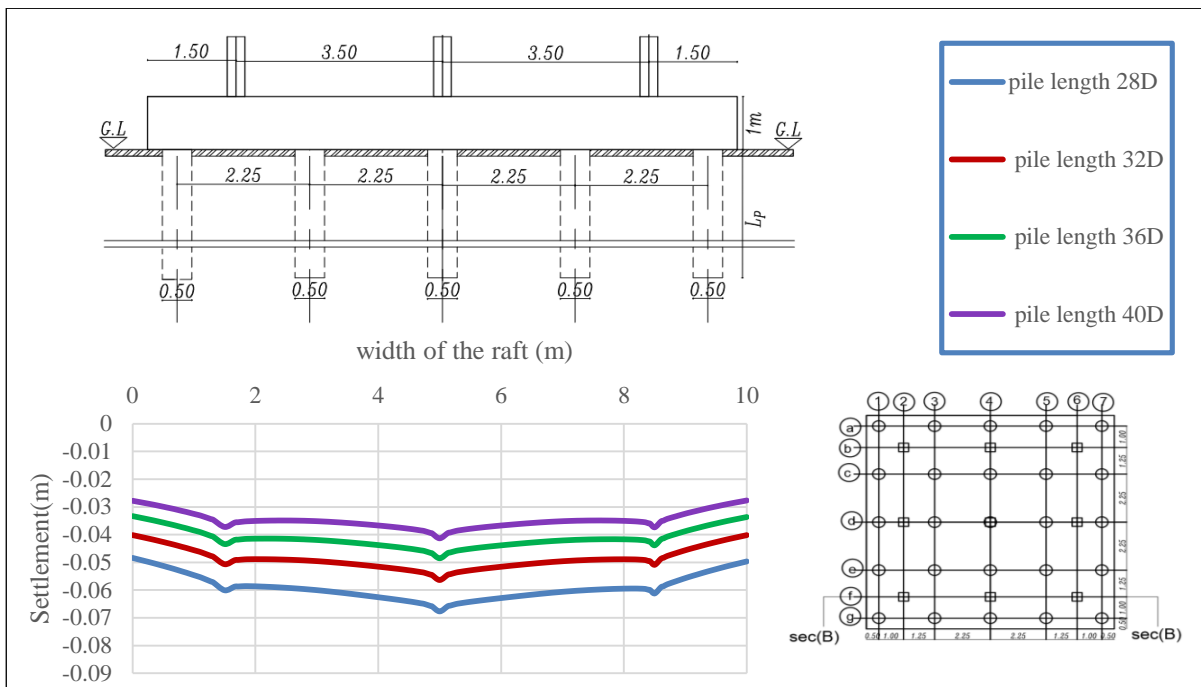

Fig (16) The relation between pile length and the settlement of piled raft foundation rested on the soil at sec B.

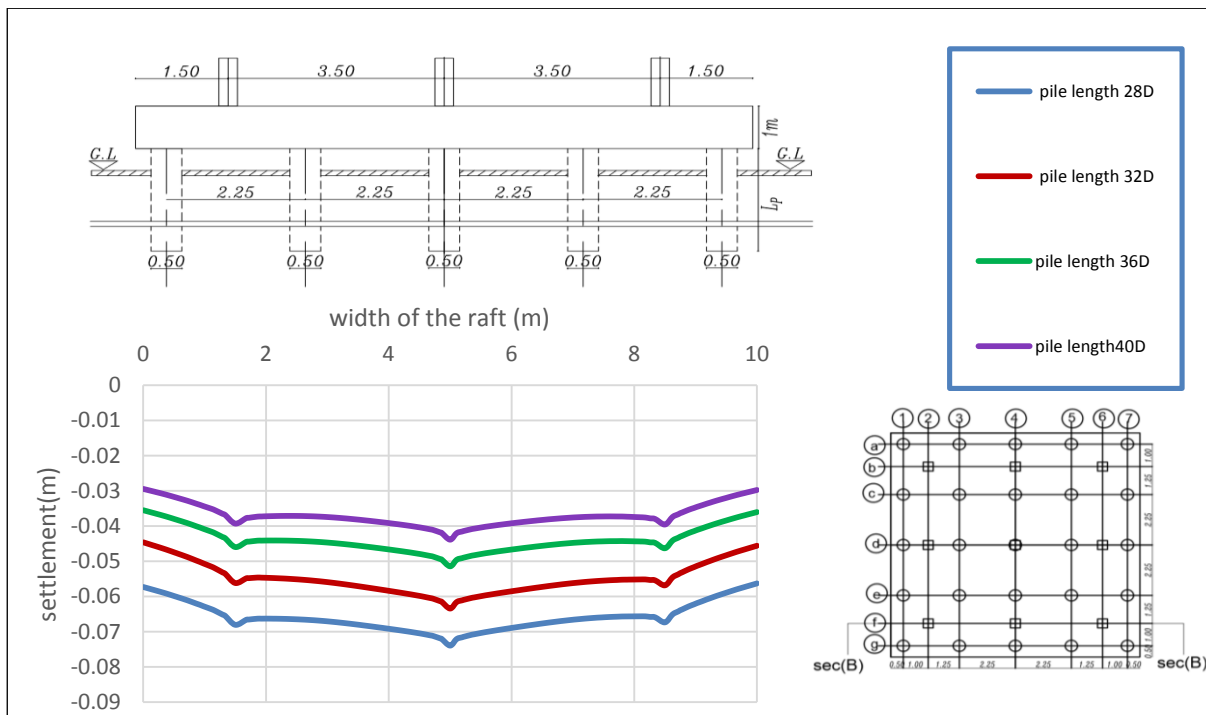

Fig (17) The relation between pile length and the settlement of piled raft foundation as the raft act at sec B.

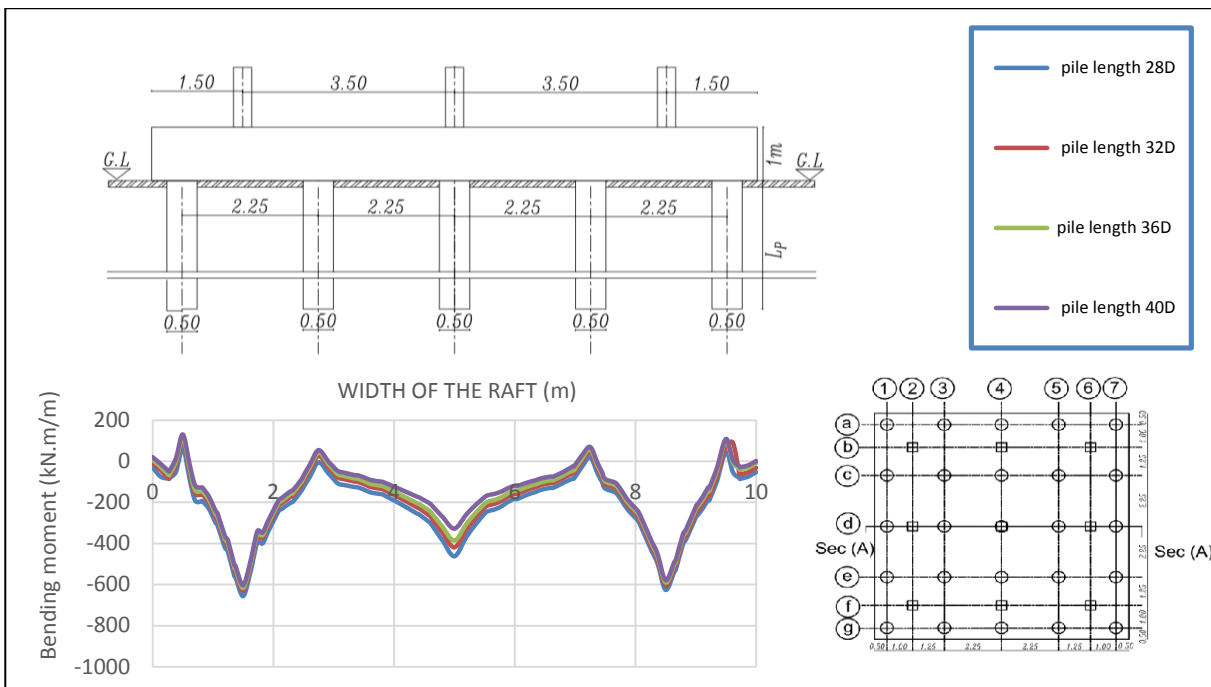

Fig (18) The relation between pile length and the bending moment on the raft of piled raft foundation rested on the soil at Sec A.

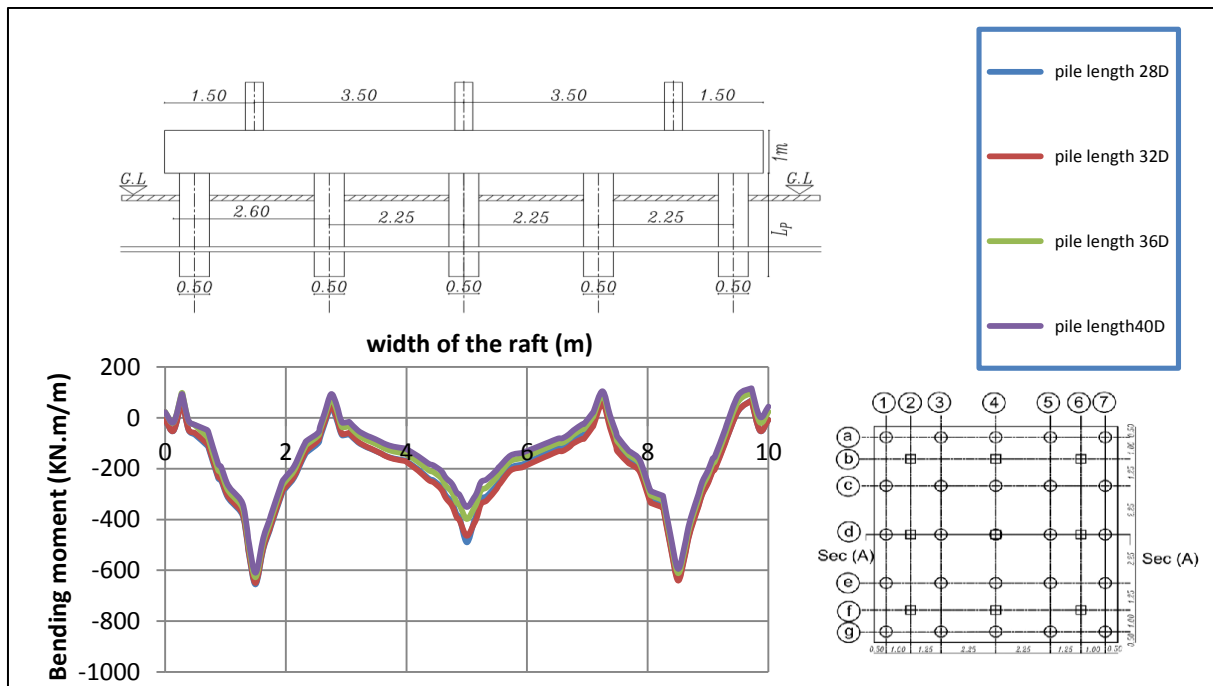

Fig (19) The relation between pile length and the bending moment on the raft of piled raft foundation as the raft acts as a slab connected to the piles at Sec A.

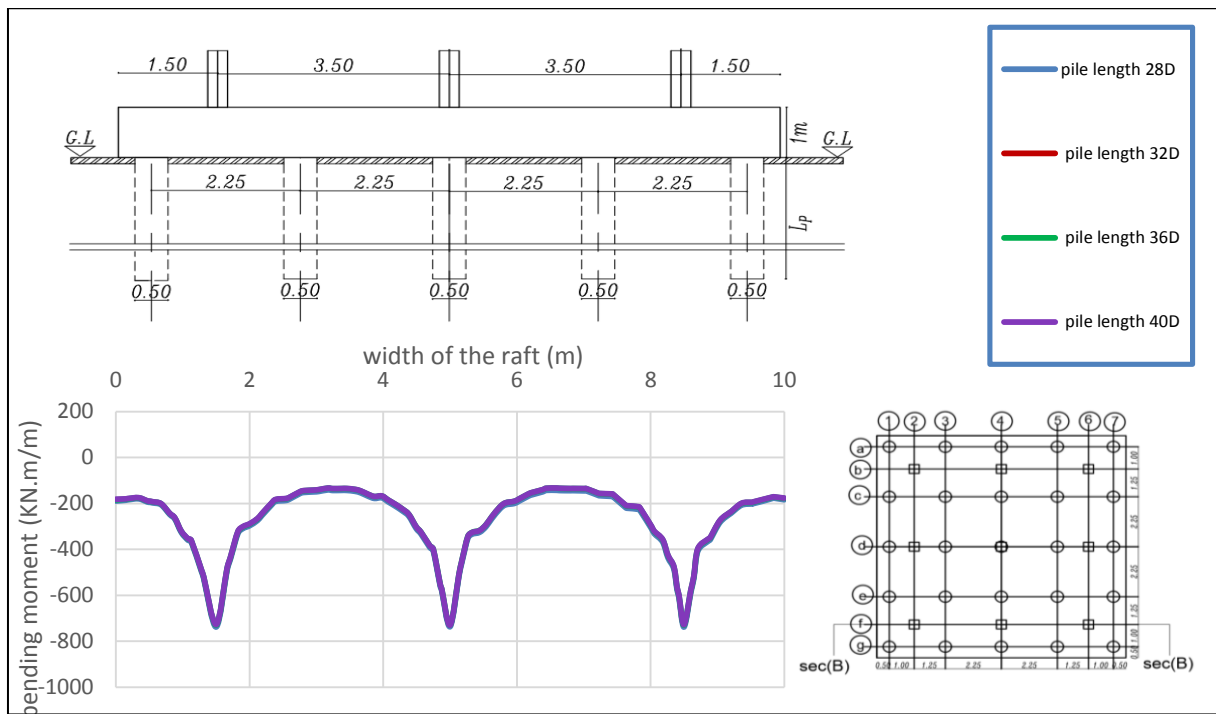

Fig (20) The relation between pile length and the bending moment on the raft of piled raft foundation rested on the soil at sec B

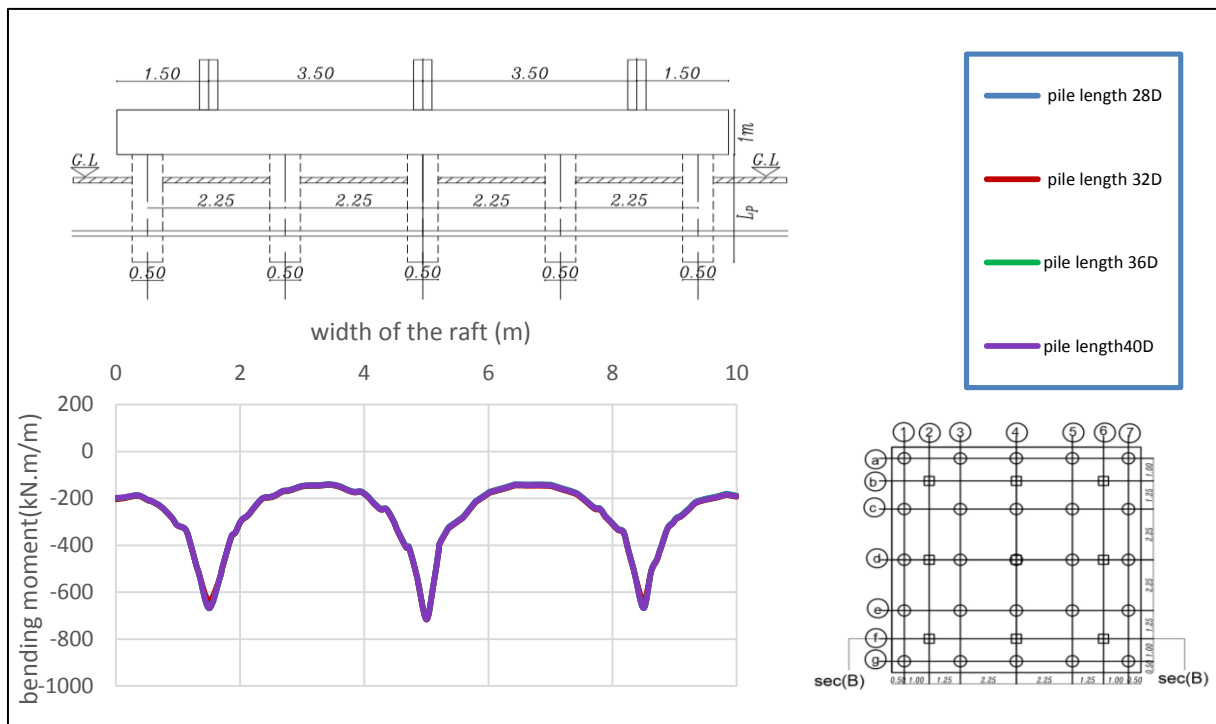

Fig (21) The relation between pile length and the bending moment on the raft of piled raft foundation as the raft act as slab connected the piles at sec B.

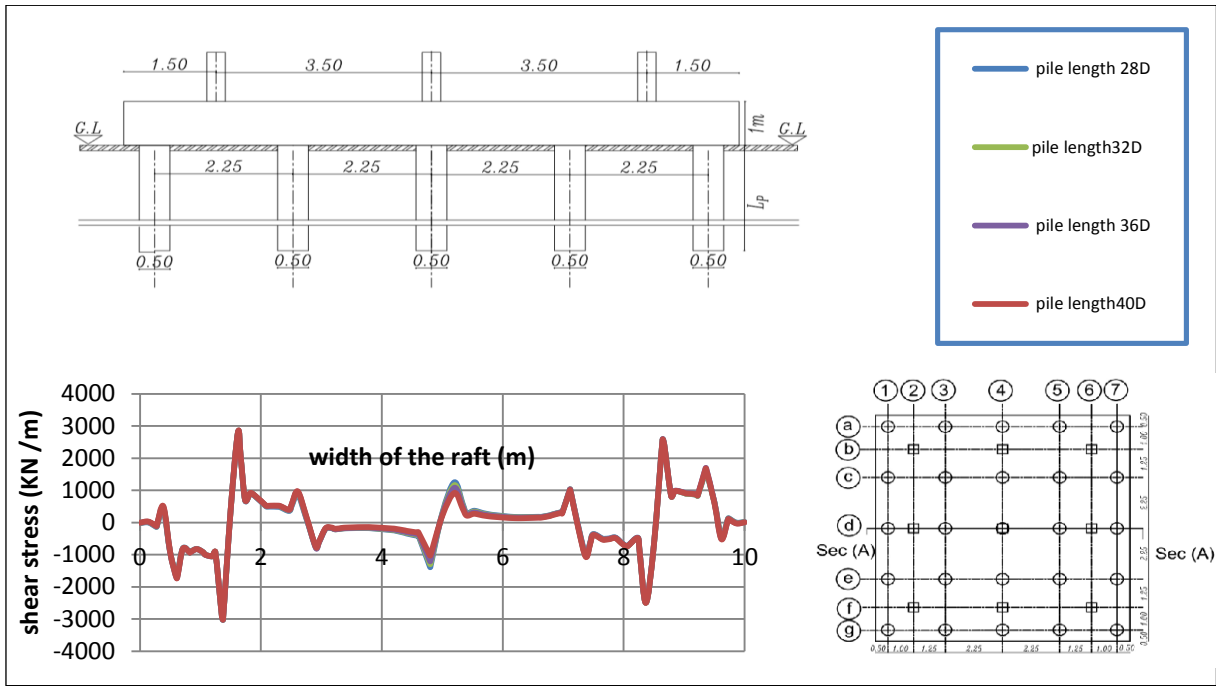

Fig (22) The relation between pile length and the shear force on the raft of piled raft foundation rested on the soil at sec A

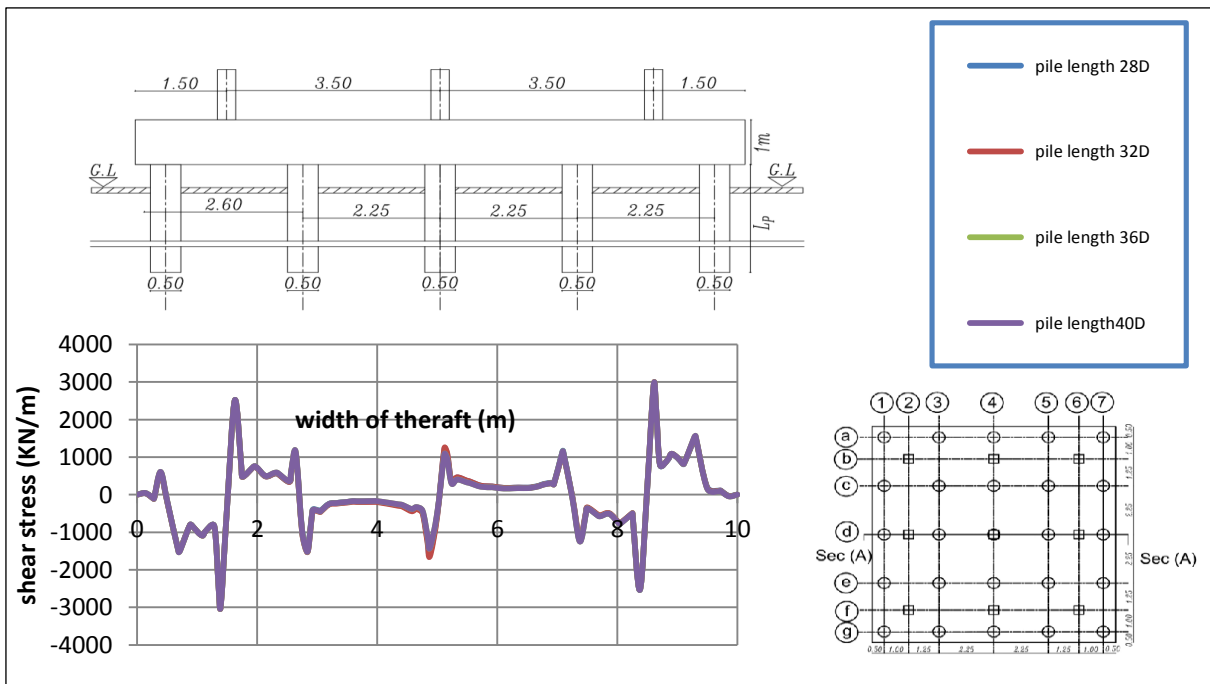

Fig (23) The relation between pile length and the shear force on a raft of piled raft foundation as raft act as slab connected the piles at sec A.

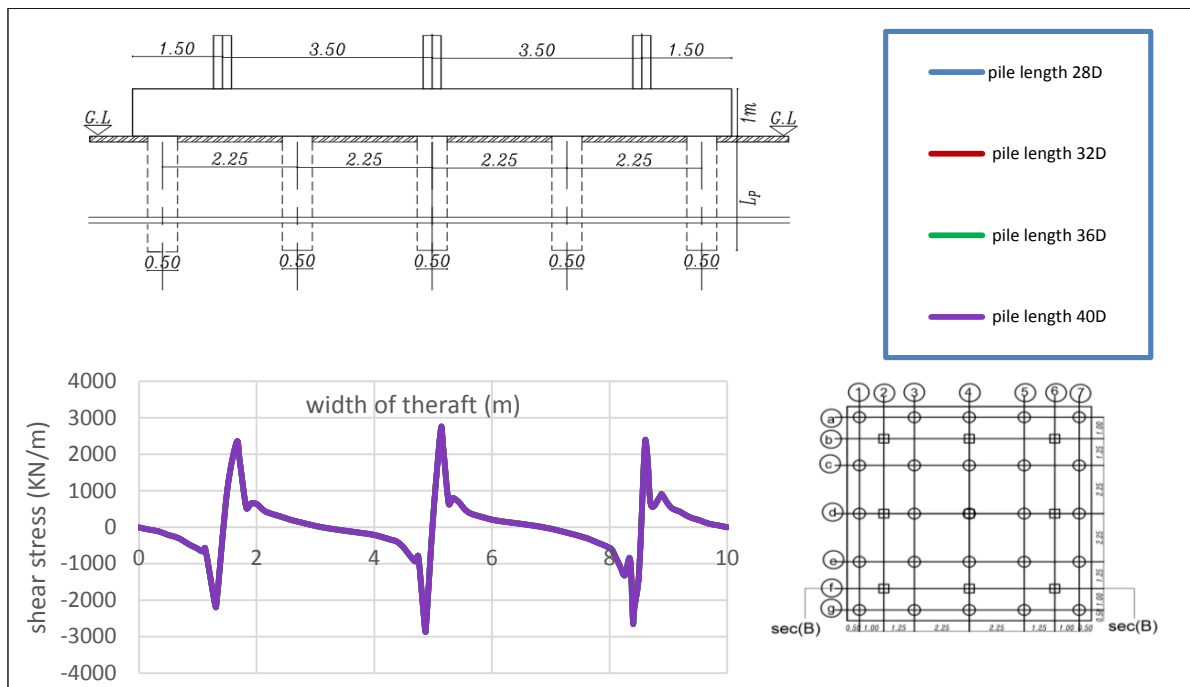

Fig (24) The relation between pile length and the shear force on the raft of piled raft foundation rested on the soil at sec B.

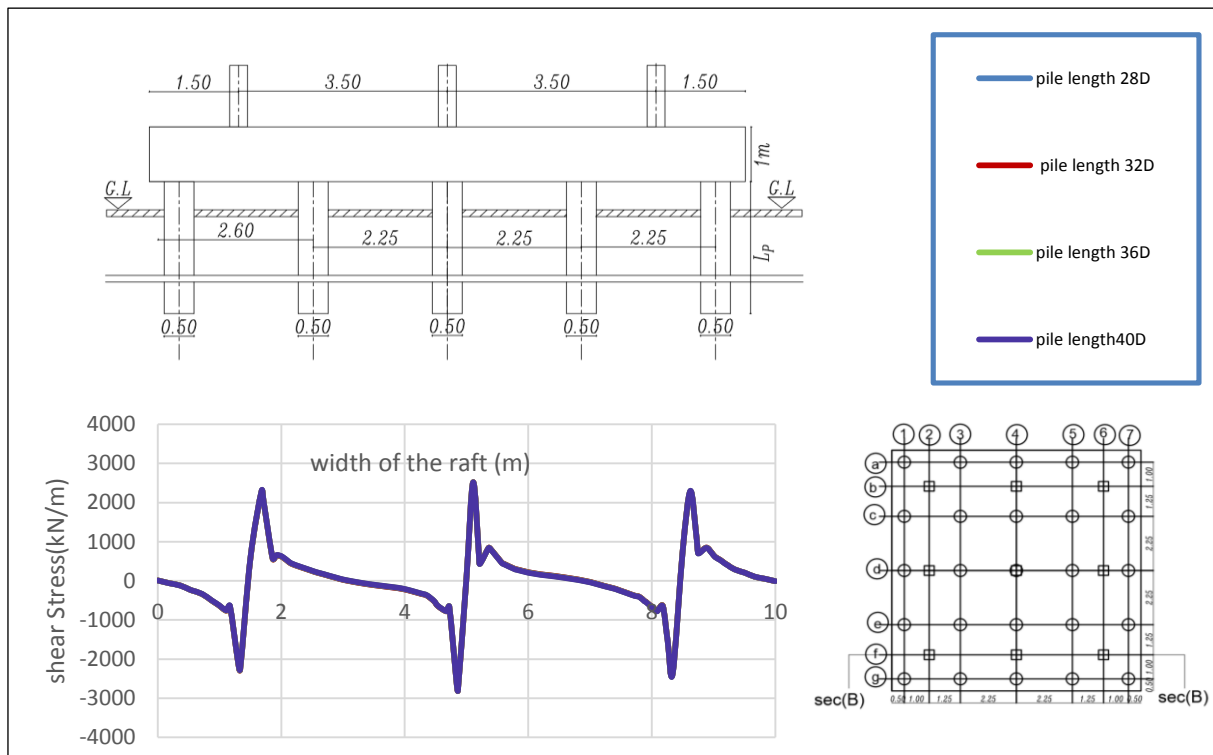
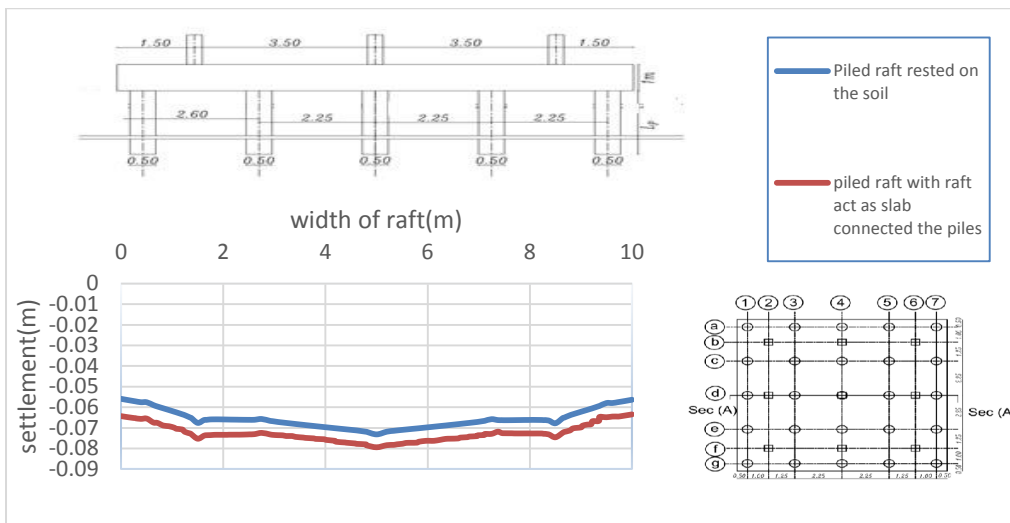
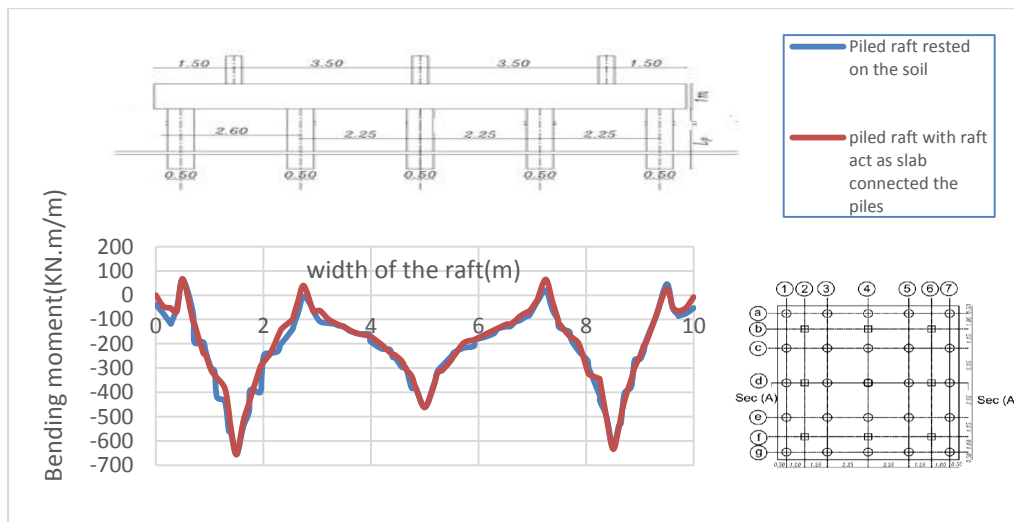

Fig (25) The relation between pile length and the shear force on the raft of piled raft foundation as the raft act as slab connected the piles at sec B.



Fig(26) show comparison in the settlement between piled raft foundation rested on the soil and piled raft foundation with raft act as slab connected the piles.



Fig(27) show comparison in the bending moment in the raft between piled raft foundation rested on the soil and piled raft foundation with raft act as slab connected the piles.

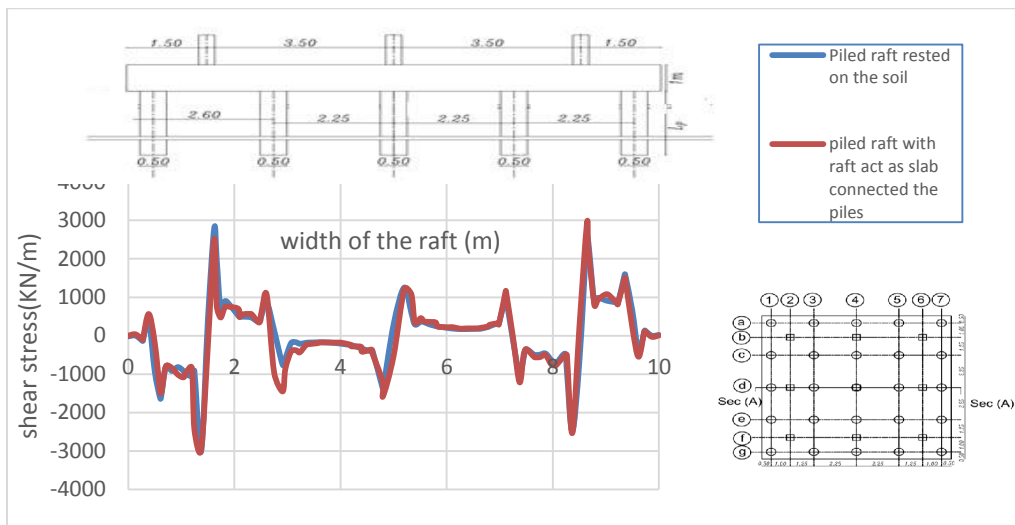

Fig(28) show comparison in the shear stress in the raft between piled raft foundation rested on the soil and piled raft foundation with raft act as slab connected the piles.

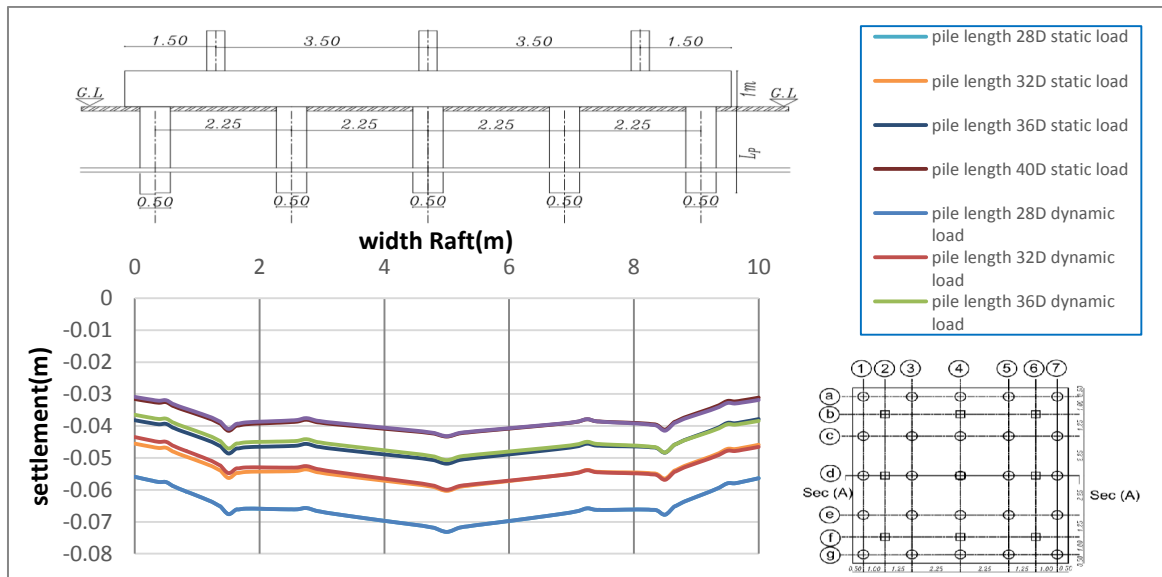

Fig (29) The relation between pile length and the settlement of piled raft foundation rested on the soil at sec A. In dynamic load

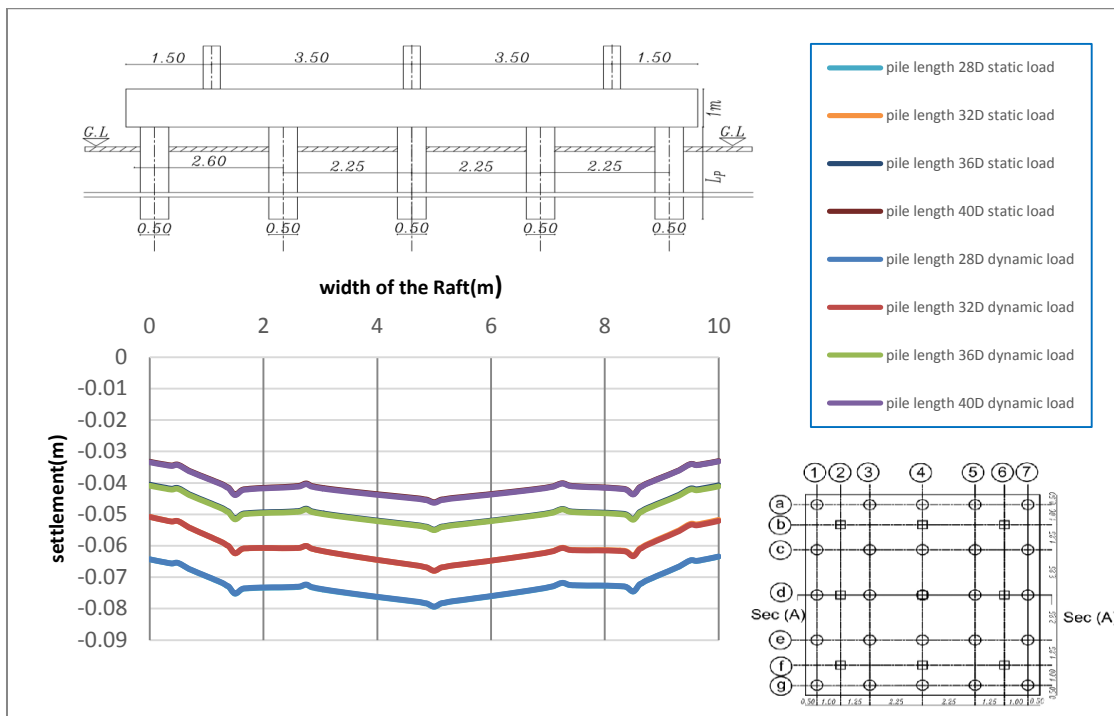

Fig (30) The relation between pile length and the settlement of piled raft foundation as the raft act as a slab at SEC A under the effect of dynamic and static load

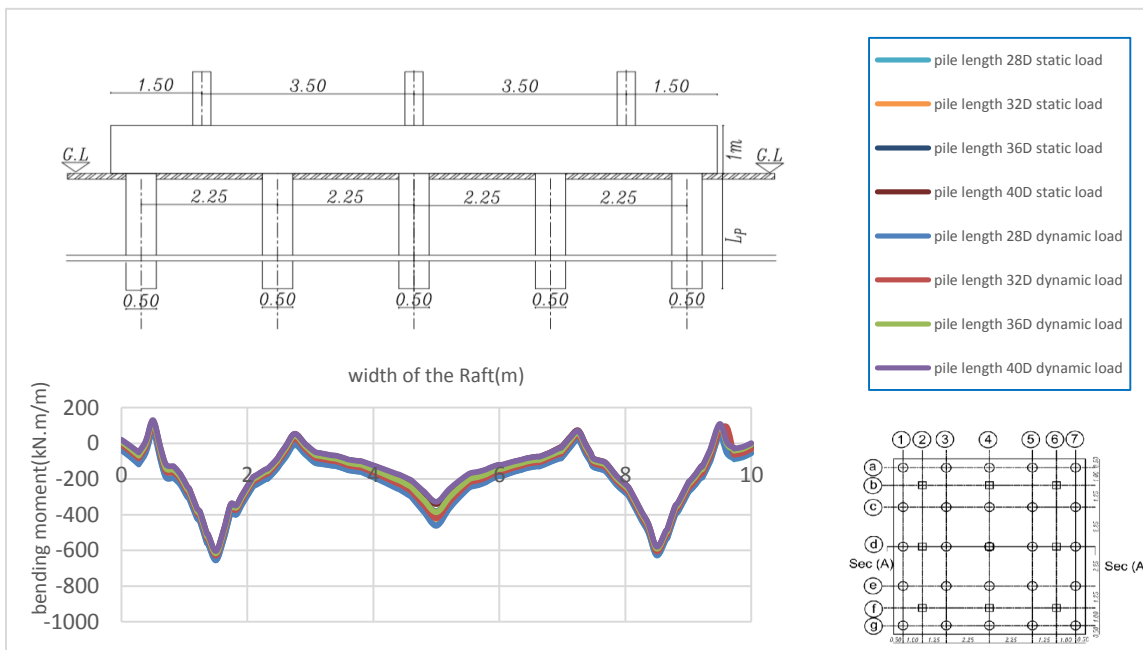

Fig (31) The relation between pile length and the bending moment on the raft of piled raft foundation rested on the soil at Sec A. under the effect of dynamic and static load

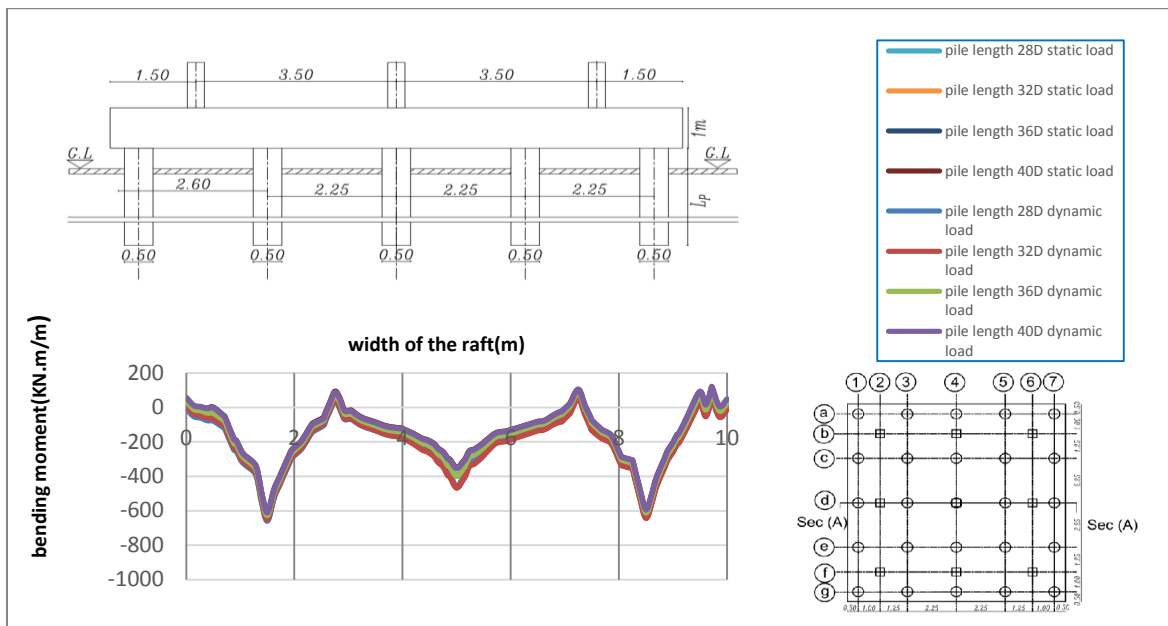

Fig (32) The relation between pile length and the bending moment on the raft of piled raft foundation as the raft act as slab connected the piles at sec A. under the effect of dynamic and static load

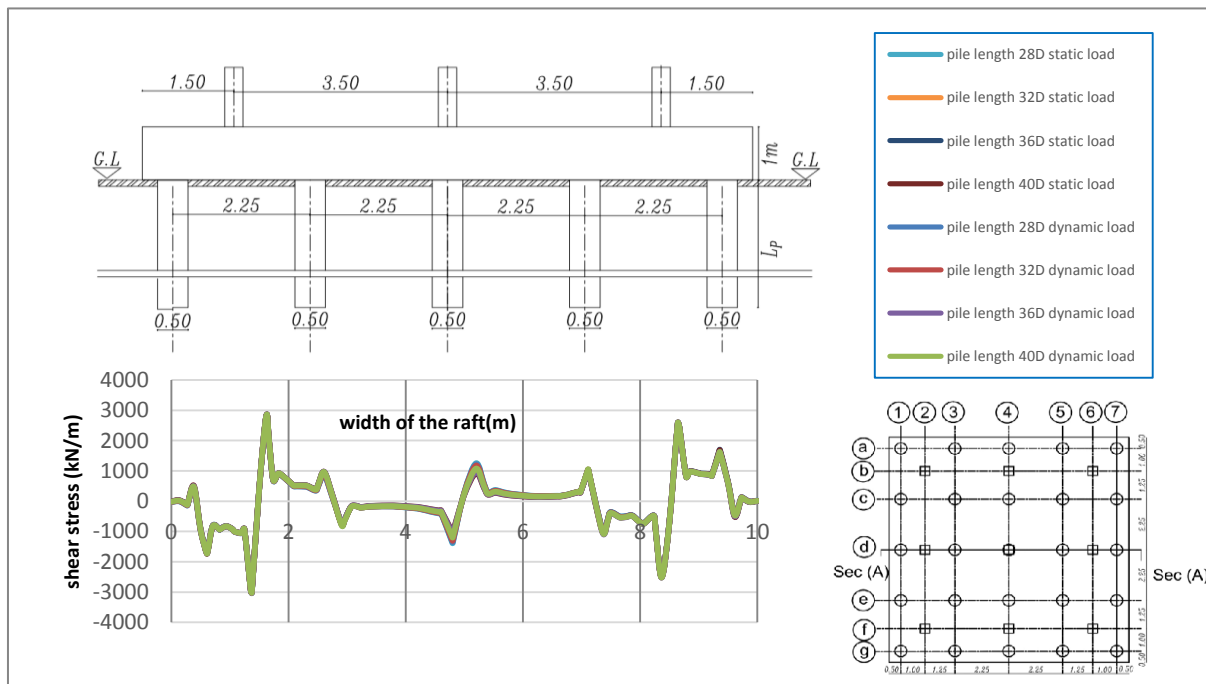

Fig (33) The relation between pile length and the shear force on the raft of piled raft foundation rested on the soil at sec A. under the effect of dynamic and static load

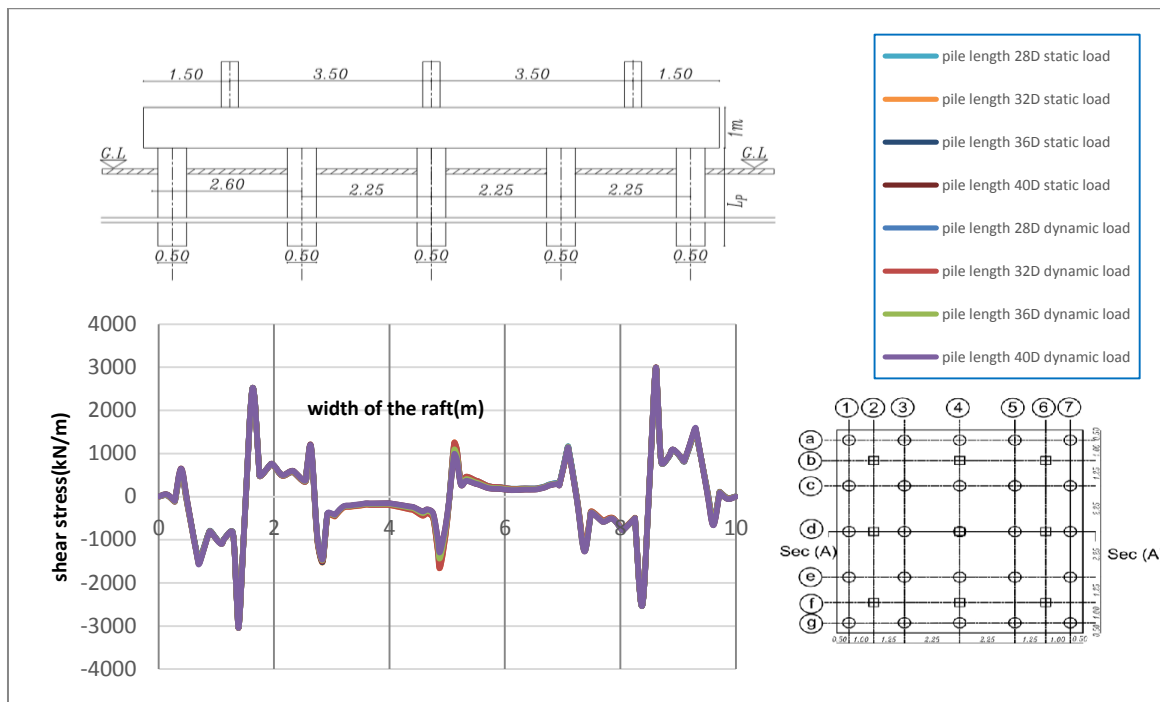

Fig (34) The relation between pile length and the shear force on a raft of piled raft foundation as raft act as slab connected the piles at sec A. under the effect of dynamic and static load

4. Conclusions:

From the present study, the followings are concluded:

i. In the case of rested piled raft increasing pile length leads to

- The bending moment in the raft decreases 29%
- The settlement decreases 40 % of piled raft foundation
- the shear force in the raft decreases from to 0.5%

ii. In the case of a raft act as a slab connected the piles increasing pile length leads to

- The bending moment in the raft decreases 20%
- The settlement decreases 35 % of piled raft foundation
- the shear force in the raft decreases 0.5%

iii. The comparison between the two cases piled raft rested on the soil and piled raft act as a slab connected the piles

- The bending moment in the raft in the case of a raft act as a slab connected to the piles is greater than the case of a rested piled raft by 10 %
- the settlement in the piled raft in the case of raft act as slab connected to the piles is greater than the case of rested piled raft by 7%
- The shear force in a raft in the case of a raft act as a slab connected the piles is greater than in the case of a rested piled raft by 2%

iv. The effect of pile length with dynamic force

In the case of rested piled raft increasing pile length leads to

- The bending moment in the raft decreases 29%
- The settlement decreases 40 % of piled raft foundation

v. the shear force in the raft decreases from 0.5% In the case of a raft act as a slab connected the piles increasing pile length leads to

- The bending moment in the raft decreases 20%
- The settlement 35 % of piled raft foundation
- The shear force in the raft decreases 0.5%.

References:

1. Akinmusuru, J. O. (1980), Interaction of Piles and Cap in Piled Footings, ASCE, Vol. 106, No. GT 11, pp. 1263-1268.
2. Bisht, R.S., and Singh, B. (2012) "Behavior Of Piled Raft Foundation By Numerical Modeling" SAITM Research Symposium On Engineering Advancements (SAITM – RSEA 2012).
3. Clancy, P. and Randolph, M. F. (1993) An Approximate Analysis Procedure for Piled Raft

Foundations, International Journal for Numerical and Analytical Methods in Geomechanics, Vol.17, No.12, pp.849.869.

4. Elsamny, M. K. and Abd EL Samee W. Nashaat and Essa. Tasneem. A (2018) "Analysis of pile-raft foundations non-rested and directly rested on soil" International Journal of Civil Engineering and Technology (IJCIET) Volume 9, Issue 3, March 2018, pp. 418-439.

5. Elsamny, M. K., Ezz-Eldeen, H. A., Elbatal, S. A. and Kamar, A. M. (2020)" Effect of Pile Length on Load Sharing Of Pile Raft Foundation under Different Loads" NEW YORK SCIENCE JOURNAL · July 2020